

SERIES 10A SERVO AMPLIFIERS Model: 10A8

FEATURES:

- Surface-mount technology
- Extremely small size
- Ease of use
- Low cost
- Single supply operation
- Four quadrant regenerative operation
- Agency Approvals:



BLOCK DIAGRAM:

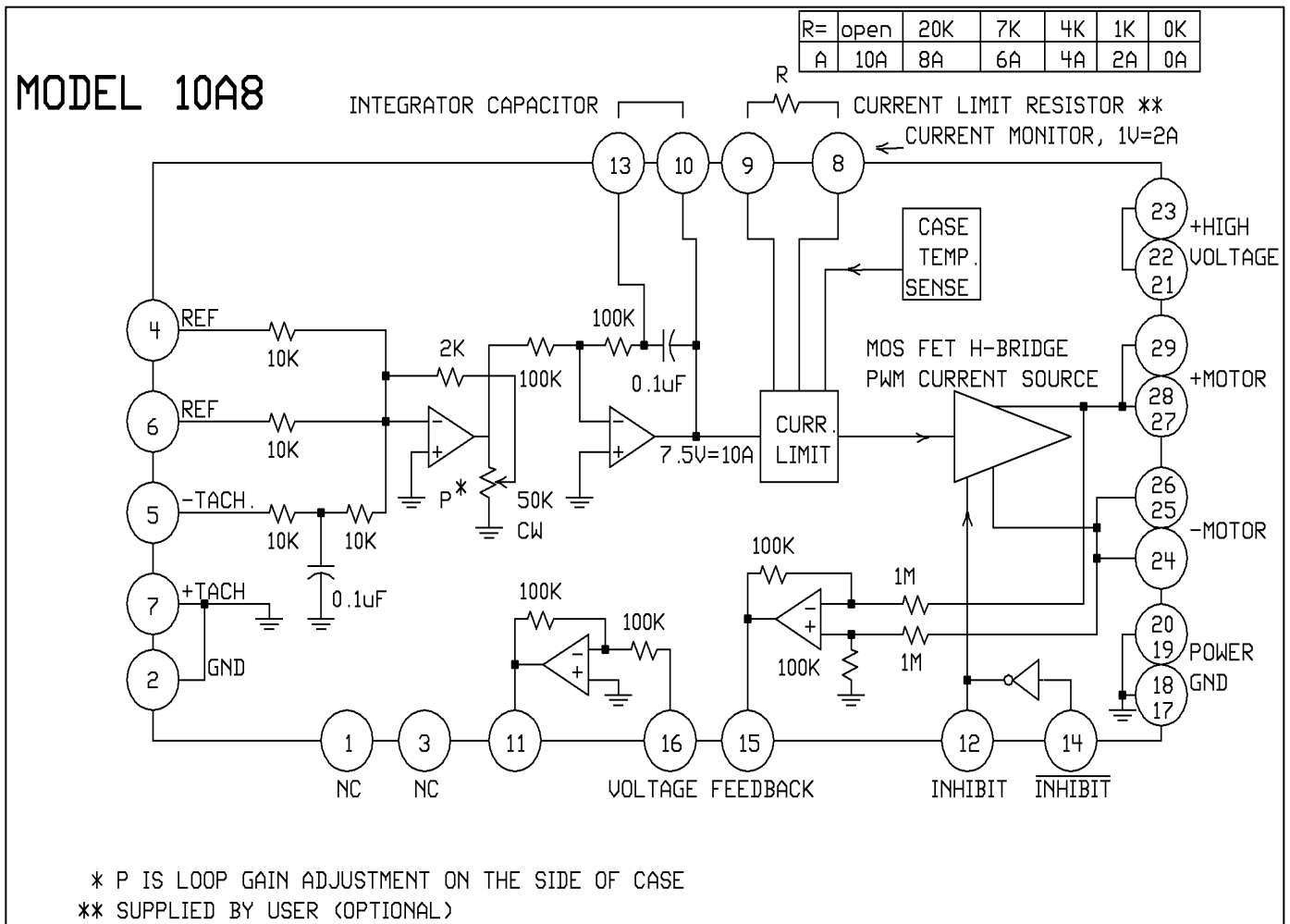

DESCRIPTION: The 10A8 PWM servo amplifiers are designed to drive brush type DC motors. The 10A8 model is fully protected against over-voltage, over-current, over-heating and short-circuits across motor, ground and power leads. This amplifier interfaces with digital controllers or can be used as a stand-alone drive. The model 10A8 requires only a single unregulated power supply. A potentiometer is located on the side for loop gain adjustment.

SPECIFICATIONS:

	MODEL
POWER STAGE SPECIFICATIONS	10A8
DC SUPPLY VOLTAGE	20-80 V
PEAK CURRENT (internally limited)	± 10 A
MAXIMUM CONTINUOUS CURRENT	± 6 A
MINIMUM LOAD INDUCTANCE*	200 µH
SWITCHING FREQUENCY	33 kHz ± 15 %
HEATSINK (BASE) TEMPERATURE RANGE	0° to +65° C, output current limit internally reduced to 0 Amps if above +65° C
POWER DISSIPATION AT CONTINUOUS CURRENT	24 W @ 6 A
OVER-VOLTAGE SHUT-DOWN (self-reset)	86 V
BANDWIDTH (load dependent)	2.5 kHz

MECHANICAL SPECIFICATIONS	
CONNECTOR	Molex connector
SIZE	4.00 x 2.00 x 0.60 inches 101.6 x 50.8 x 15.2 mm
WEIGHT	5.1 oz. 0.145 kg

* Low inductance motors ("pancake" and "basket-wound") require external inductors.

 **CAUTION:** WHEN NOT MOUNTED DIRECTLY ON FACTORY SUPPLIED MATING MOUNTING CARDS, POWER LEADS LONGER THAN ONE FOOT REQUIRE EXTERNAL BY-PASS CAPACITORS (MIN. 1000 µF) FOR HIGH VOLTAGE. PLEASE CONTACT FACTORY FOR ADDITIONAL INFORMATION.

PIN FUNCTIONS:

CONNECTOR	PIN	NAME	DESCRIPTION / NOTES	I/O
P1	1	NC		NC
	2	GND	Signal Ground, Common to P1-17 through P1-20	GND
	3	NC		NC
	4	REF	Maximum ± 15 V, 10K input resistance	I
	6			
	5	TACH	Maximum ± 60 V DC, 20K Input Resistance	I
	7			
	8	CURRENT MONITOR	Current monitor. This DC signal is proportional to the actual current in the motor leads: 1 V = 2 A. Also see pin P1-9 description.	O
	9	CURRENT LIMIT	The external current limiting resistor connects between P1-8 and 9. See functional block diagram above for values.	I
	10	CURRENT REFERENCE	Command signal to the internal current-loop. The maximum peak current rating of the amplifier (10A) always equals 7.25V at this pin. See P1-13 and current limit adjustment information below.	O
	11	INV.OUT	Output of the internal unity-gain inverting amplifier.	O
	12	INHIBIT	Apply +3 V to +15 V @ 1 mA to inhibit drive	I
	13	INTEGRATOR	Shorting this pin to P1-10 eliminates the velocity/voltage loop integrator. This provides direct access to the internal current loop (current mode). The potentiometer on the side of the case can be used to adjust the input-voltage to output-current ratio in current mode.	O
	14	INHIBIT	Inhibit turns off all four mosfets of the "H" bridge drive when pulled to ground. Leaving this pin open or connecting it to +15 V enables the amplifier module.	I
	15	VOLTS OUT	Output of the internal differential amplifier. This signal is proportional to the output voltage.	O
	16	INV. IN	Input of the internal unity-gain inverting amplifier	I
	17-20	POWER GND	Power Ground, Common to P1-2	GND
	21-23	+ HIGH VTG	DC Power Input	I
24-26	- MOTOR	Negative Motor Output	O	
27-29	+ MOTOR	Positive Motor Output	O	

OPERATING MODE SELECTION:

10A Series amplifiers operate in the following modes:

- Voltage Mode
- Velocity Mode (tachometer required)
- Current (Torque) Mode

Use of mating mounting card is required for the following mode:

- Analog Position Loop mode

Voltage mode can be selected for model 10A8 by shorting pins P1-15 and P1-5. Current (Torque) mode can be selected for model 10A8 by shorting pin P1-10 to P1-13.

See section "G" for more information.

CURRENT LIMIT ADJUSTMENTS:

These amplifiers feature a single current limit adjustment. If due to extremely harsh operating conditions over-heating occurs, the internal analog temperature sensor automatically reduces the current limit to a safe level without interrupting operation or damaging the amplifier. The current limit can also be reduced by connecting an external resistor between pins P1-8 and 9. See chart on the functional block diagram above for values.

Pin P1-10 is the input to the internal current amplifier stage. Since the output current is proportional to P1-10, the adjusted current limit can easily be observed at this pin. Note that a command signal must be applied to the reference inputs to obtain a reading on P1-10. The maximum peak current value equals 7.25V at this pin and the maximum continuous current value equals 3.63 V at this pin. For example: 7.25V=10A.

The actual current can be monitored at pin P1-8.

RECOMMENDED MOUNTING CARDS:

Mounting cards: MC1X510, MC2X510, MC3X510, MF1X510, MF2X510 and MF3X510

TYPICAL SYSTEM WIRING: See section "G".

ORDERING INFORMATION:

Model: 10A8X

X indicates the current revision letter.

MOUNTING DIMENSIONS: See page F-5.