

Diffuse reflection sensor

OJ5078

OJH-FPKG/SO/0.15M/US
Rectangular plastic
Cable with connector

Electronic lock
External teach function
Background suppression
Side sensing

Range 15 ... 400mm
(Range referred to white paper
200 x 200 mm, 90 % remission)
adjustable

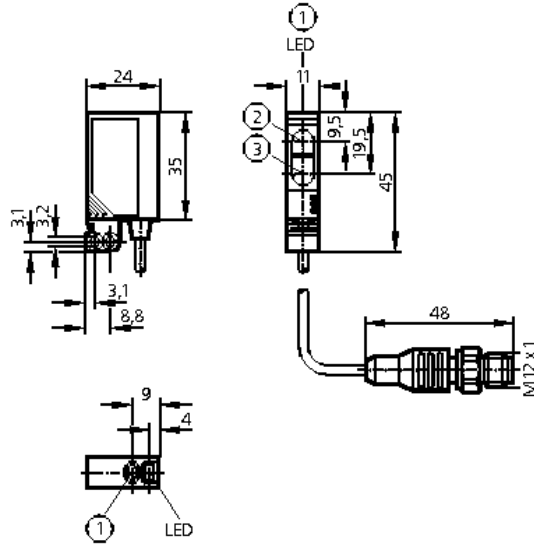

1: push button 2: receiver 3: transmitter

Electrical design	DC PNP
Output	light-on / dark-on programmable
Light spot diameter [mm]	< 18 (TW=150mm)
Operating voltage [V]	10...30 DC
Current rating [mA]	200
Short-circuit protection	pulsed
Reverse polarity protection	yes
Overload protection	yes
Voltage drop [V]	< 2.5
Current consumption [mA]	< 21
Switching frequency [Hz]	1000
Type of light	Transmitter red light 660 nm
Operating temperature [°C]	-25...60
Protection	IP 68 / IP 69 K ☐
EMC	EN 60947-5-2
Housing material	housing: ABS; fixture: diecast zinc; LED window: SEPS; pushbutton: SEPS; connector body: Hytrel 8068; connector thread: stainless steel (316S12)
Material lens	PMMA
Function display	
Switching status LED	yellow
Operation LED	green
Connection	PVC cable / 0,15 m; M12 connector, gold-plated contacts
Wiring	



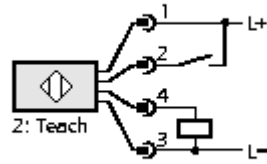

Remarks

cULus - Class 2 source required

Accessories (included)

Basic clip, E20964, 2 mounting screws, M3 x 16, 2 spring washers, 2 nuts

ifm electronic gmbh · Teichstraße 4 · D-45127
Essen

— We reserve the right to make technical alterations without prior notice. — GB - OJ5078 — 06.03.2003