

Rittal
SK



**Schaltschrank-
Kühlgerät**

Cooling unit

Climatiseur

Koelaggregaat

Kylaggregat

**Condizionatore
per armadi**

**Refrigerador
para armarios**

クーリングユニット



SK 3296.100
SK 3296.500
SK 3296.140
SK 3296.540
SK 3272.100
SK 3290.100
SK 3290.500
SK 3290.140
SK 3290.540
SK 3280.100
SK 3256.100
SK 3256.500
SK 3256.140
SK 3256.540

Montageanleitung

Assembly instructions

Notice de montage

Montage-instructie

Montageanvisning

Istruzioni di montaggio

Instrucciones de montaje

取扱説明書

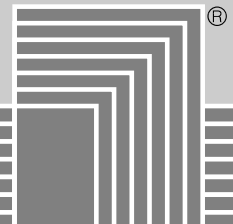

Umschalten auf Perfektion

RITTAL

D**ACHTUNG!****Montage von Schaltschrank-Kühlgeräten**

Bei der Montage ist zu beachten, daß Warmlüftein- und Kaltluftaustritt nicht zu verbauen sind. Eine ungehinderte Luftzirkulation im Innenkreislauf ist zu gewährleisten. Ein Abstand zu den Luftaus- und -eintrittsoffnungen von 200 mm bis zur Installation ist einzuhalten. Wird das Gerät vom Netz getrennt, darf ein erneutes Einschalten erst nach einer Wartezeit von > 5 min. erfolgen.

Einsatz von Türpositionsschaltern bei Kühlgeräten

Serie .100 / .140: Die o.g. Wartezeit muß z. B. durch die Verwendung eines Zeitrelais sichergestellt werden.
Serie .500 / .540: Die o.g. Wartezeit wird durch den integrierten Microcontroller sichergestellt. Pro Gerät ist ein potentialfreier Türpositionskontakt zu verwenden; es dürfen auf keinen Fall mehrere Geräte über einen Türpositionsschalter betrieben werden.
In Umgebungen mit erhöhter elektromagnetischer Störung muß eine geschirmte Leitung verwendet werden. Der Türkontakt ist über zusätzliches Relais, das in der Nähe des Gerätes platziert ist, zu schalten. Die Leitungen sind getrennt von den Netzleitungen zu verlegen. Auf kurze Leitungswege achten!

Einsatz von Motor- bzw. Trafoschutzschaltern bei Kühlgeräten

Drehstromgeräte sind über einen Motorschutzschalter an ein TN-Netz mit geerdetem Sternpunkt anzuschließen. Beim Einsatz von Schaltschrank-Kühlgeräten der Serie .140 / .540 mit Transformatoren und Geräten in Sonderspannung, die ebenfalls mit Trafo ausgerüstet sind, sind normale Motorschutzschalter von ihrer Einschaltcharakteristik nicht mehr ausreichend. Deshalb müssen kundenseitig Trafoschutzschalter installiert werden. Diese sind auf den auf dem Typenschild angegebenen Nennstrom einzustellen.

S**VARNING!****Montering av apparatskåpskyllaggregat**

Vid montering måste beaktas att varmluftsintag och kallluftutblås inte är spärrade. En fri luftcirkulation inuti skåpet måste garanteras. Utrymmet mellan luftintag, utblåsöppningar och installationerna måste vara 200 mm. Efter att kylaggregatet stängts av kan det startas först efter 5 minuter.

Användning av dörrkontakt med kylaggregat

Vid serierna .100 / .140 måste den ovan nämnda väntetiden åstadkommas genom ett tidrelä.
Vid serierna .500 / .540 måste en potentialfri dörrkontakt användas per enhet, det får heller aldrig användas mer än en enhet per dörrkontakt. I miljöer med hög elektromagnetisk påverkan måste en skärmad kabel användas. Dörrkontakten ska kopplas via ytterligare ett relä, vilket placeras nära enheten. Kablage dras skiljt från nåledningen. Se till att kablarna är så korta som möjligt!

Användning av motor- resp transformatorskyddsbrytare med kylaggregat

Trefasaggregat ansluts via en motorskyddsbrytare till ett TN-nät med jordad nollpunkt. Om kylaggregat ur serierna .140 / .540 används med transformatorer och enheter med specialspänning, även de utrustade med transformatorer, räcker inte standard motorskyddsbrytare beroende på deras slutna kretsar. Därför måste transformatorskyddsbrytare installeras. Dessa ska ställas in på den på typskylten angivna nätströmmen.

GB**ATTENTION!****Installation of cooling units**

Please make sure during installation that warm air inlet and cold air outlet are not obstructed. An unobstructed air circulation in the inside circuit has to be ensured. A distance of 200 mm from air inlet and air outlet openings to the installed equipment should be respected. After disconnection of the cooling unit, waiting period of > 5 min. before reactivation.

Use of door operated switch with cooling units

Series .100 / .140: The mentioned above waiting period has to be ensured by using a time relay.
Series .500 / .540: One potential-free door operated contact has to be used per unit, never operate more than one unit via one door operated switch. In environments with high electromagnetic interference a shielded cable has to be used. The door contact is to be connected via an additional relay, which is placed near the unit. The cables and the supply line are to be laid separately. Please ensure that the cables are as short as possible.

Use of motor or transformer protection switch with cooling units

Three-phase devices are to be connected via a motor protection switch to a TN network with earthed neutral. If units of series .140 / .540 are used with transformers and units with special voltage, also equipped with transformer, standard motor protection switches are not sufficient due to their closed circuit condition. That is why transformer protection switches have to be installed by the customer, and have to be adjusted to the rated current on the type plate.

F**ATTENTION!****Montage des climatiseurs d'armoires électriques**

Veiller lors du montage à n'obstruer ou gêner ni l'entrée de l'air chaud ni la sortie de l'air froid. L'air doit pouvoir circuler librement dans le circuit intérieur. Respecter un écartement de 200 mm entre l'appareil installé et les ouvertures d'entrée et de sortie d'air. Lorsque l'appareil a été coupé du secteur, attendre au moins 5 minutes avant de le remettre en circuit.

Utilisation d'un interrupteur de porte avec les climatiseurs

Séries .100 / .140: La durée d'attente mentionnée plus haut sera assurée en installant un relais retardeur.
Séries .500 / .540: Utiliser un interrupteur de porte sans potentiel pour chaque appareil. Ne jamais faire fonctionner plusieurs appareils avec un seul interrupteur de porte.
Lorsque le milieu ambiant est soumis à d'importantes interférences électromagnétiques, utiliser un câble avec contacteur de protection. Monter le contact de la porte avec un relais supplémentaire placé à proximité de l'appareil. Lors de la pose des conducteurs, veiller à les séparer des lignes d'alimentation et choisir la voie la plus courte.

Utilisation d'un contacteur-disjoncteur ou disjoncteur de protection pour transformateur dans les climatiseurs d'armoires électriques

Les appareils à courant triphasé doivent être connectés par un contacteur-disjoncteur au réseau TN avec neutre mis à la terre. Dans le cas des climatiseurs d'armoires électriques des séries .140 / .540, équipés de transformateurs et dans le cas des appareils avec tensions spéciales également équipés de transformateurs, les propriétés d'enclenchement des disjoncteurs standard ne sont pas suffisantes. Le client devra alors prévoir des disjoncteurs de protection pour transformateurs et les régler sur la valeur du courant nominal indiquée sur la plaque signalétique.

NL**LET OPI!****Montage van schakelkast-koelaggregaten**

Bij de montage dient erop te worden gelet dat de aanzuigopeningen van de warme lucht en de inblaasopeningen van de koude lucht niet mogen worden gemodificeerd. Anders kan geen ongehinderde luchtcirculatie in het binnencircuit worden gegarandeerd. Tussen de luchtanzuig-, luchtinblaasopeningen en de installatie dient een afstand van minimaal 200 mm te worden aangehouden. Wordt het aggregaat van het net gescheiden, dan mag het pas na een wachttijd van tenminste 5 minuten opnieuw worden ingeschakeld.

Toepassing van deurschakelaars bij koelaggregaten

Serie .100 / .140: De hierboven genoemde wachttijd dient door toepassing van bijv. een tijdrelais te worden zekergesteld. Serie .500 / .540: Per aggregaat één potentiaalvrij deurcontact te worden toegepast; er mogen in geen geval meerdere aggregaten op één deurschakelaar worden aangesloten. In omgevingen waar verhoogde elektromagnetische storingen voorkomen, dient een afgeschermd kabel te worden toegepast. Het deurcontact aan een extra relais, dat in de buurt van het aggregaat is aangebracht, worden geschakeld. De kabels diene gescheiden van de netvoedingskabels te worden gelegd. Let erop dat zo kort mogelijke kabels worden gebruikt!

Inzet van motor respectievelijk transformatorbeveiligingsschakelaar bij koelaggregaten

Draaisroomaggregaten zijn via een motorbeveiligingsschakelaar aan een TN-stelsel met geaard sterpunt niet te sluiten. Bij de toepassing van schakelkast-koelaggregaten van de serie .140 / .540 met transformatoren en aggregaten met afwijkende spanningen die ook zijn voorzien van een transformator zijn standaard motorbeveiligingsautomaten niet voldoende als gevolg van hun inschakelkarakteristiek. Daarom dienen trafobeveiligingsschakelaars door de klant zelf te worden geïnstalleerd en te worden ingesteld volgens de op het typeplaatje aangegeven nominale stroom.

I**ATTENZIONE!****Installazione di condizionatori**

Durante il montaggio accertarsi che l'entrata aria calda e l'uscita aria fredda non siano ostruite. Occorre assicurare la libera circolazione dell'aria nel circuito interno, nonché rispettare una distanza di 200 mm dalle aperture di entrata e scarico aria al luogo di installazione. Una volta disinstallato l'apparecchio è possibile riavviarlo soltanto dopo > 5 min. di attesa.

Impiego di interruttori di posizione porta nei condizionatori

Serie .100 / .140: il suddetto tempo di attesa prima di riavviare l'apparecchio deve essere rispettato utilizzando ad es. un relai a tempo.
Serie .500 / .540: il tempo di attesa sopra indicato viene assicurato dal microcontroller integrato. Si deve utilizzare un interruttore di posizionamento porta per ogni apparecchio; non è possibile in nessun caso azionare più apparecchi con un interruttore. In ambienti particolarmente soggetti ad interferenze elettromagnetiche occorre utilizzare un cavo schermato. L'interruttore per la porta dovrà essere collegato ad un ulteriore relai, situato vicino all'apparecchio. I cavi e le linee elettriche devono essere posati in sede separata. Prevedere linee di connessione con lunghezza limitata.

Impiego di interruttori di protezione trasformatore nei condizionatori

I normali interruttori di protezione dei motori, per le loro caratteristiche, non sono più sufficienti per essere impiegati sui condizionatori della serie .140 / .540 con trasformatore e apparecchiature a tensione speciale, dotate anch'esse di trasformatore. Il cliente dovrà quindi installare interruttori di protezione del trasformatore, da tarare in base al valore della corrente nominale indicata sulla targhetta.

E**¡ATENCIÓN!****Montaje de refrigeradores**

En el montaje debe tenerse en cuenta que la entrada de aire caliente y la salida de aire frío no se encuentren obstruidas. Debe garantizarse una circulación adecuada del aire en el circuito interior. Debe mantenerse una distancia de 200 mm entre las escotaduras de salida y de entrada de aire hasta el punto de instalación. Tras la desconexión del aparato deben transcurrir > 5 min. hasta la próxima conexión.

Uso de interruptores de posición de puerta en refrigeradores

Serie .100 / .140: El tiempo de reposo mencionado arriba debe garantizarse mediante el montaje de un relé de tiempo.
Serie .500 / .540: Debe utilizarse un contacto libre de potencial de posición de puerta por aparato; en ningún caso deberá utilizarse un solo interruptor final para más de un aparato. En entornos con elevada perturbación electromagnética debe utilizarse un cable apantallado. El contacto de puerta debe conectarse a través de un relé adicional situado cerca del aparato. Los cables deben tenerse separados de los cables de red. Procure que los cables sean lo más cortos posibles.

Uso de interruptores de protección de motores o de transformadores en refrigeradores

Los aparatos de corriente trifásica deben conectarse mediante un interruptor de protección de motores a una red TN con toma de tierra en forma de estrella. Con la aplicación de los refrigeradores para armarios de las series .140 / .540 con transformadores y aparatos con tensión especial, equipados también con transformadores, los interruptores de protección de motor normales son insuficientes a causa de sus características de conexión. Por tal motivo el cliente deberá instalar un interruptor de protección de transformador. Estos deben ajustarse en función de la corriente nominal indicada en la placa de características.

J

SK 3296... / 3272.100

- Abb. 3.1 Montageausschnitte
- Fig. 3.1 Mounting cut-out
- Fig. 3.1 Découpe de montage
- Afb. 3.1 Montage-uitsparingen
- Bild 3.1 Håltagning
- Fig. 3.1 Dime di foratura
- Fig. 3.1 Recorte del montaje
- 図 3.1 取付用カットアウト図

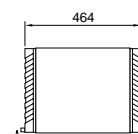
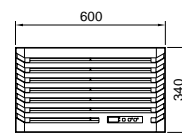
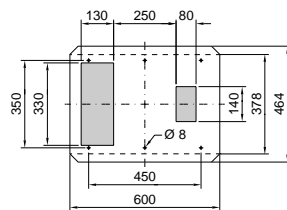

SK 3290... / 3280.100

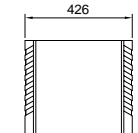
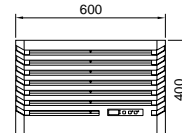
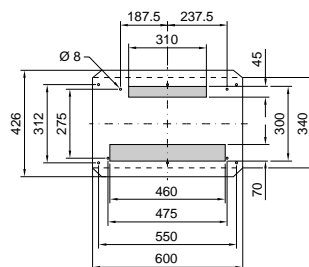

SK 3256...

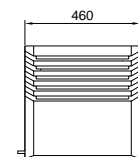
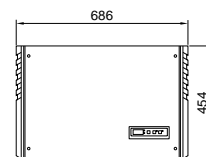
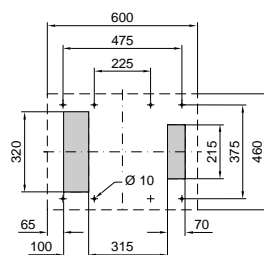

- Abb. 3.2 Dachblechversteifung SK 3256...
- Fig. 3.2 Roof plate stiffening SK 3256...
- Fig. 3.2 Renforcement du toit en tôle SK 3256...
- Afb. 3.2 Versteving van het dak SK 3256...
- Bild 3.2 Takplåtsförstärkning SK 3256...
- Fig. 3.2 Rinforzare la lamiera del tetto SK 3256...
- Fig. 3.2 Refuerzo del techo SK 3256...
- 図 3.2

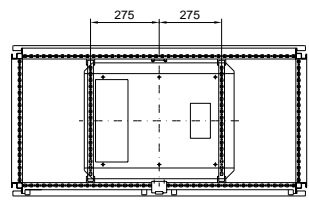

- Abb. 3.3 Gerätemontage
- Fig. 3.3 Mounting
- Fig. 3.3 Montage
- Afb. 3.3 Montage
- Bild 3.3 Montage
- Fig. 3.3 Montaggio
- Fig. 3.3 Montaje
- 図 3.3 ユニット取付

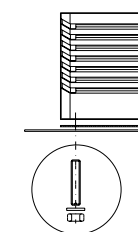

- Tab. 2.1 Technische Daten
- Tab. 2.1 Technical data
- Tab. 2.1 Données techniques
- Tab. 2.1 Technische gegevens
- Tab. 2.1 Tekniska data
- Tab. 2.1 Caratteristiche tecniche
- Tab. 2.1 Datos técnicos
- 表 2.1 仕様

D	Betriebsspannung	Nennstrom	Anlaufstrom	Vorsicherung T	Einschalt-dauer	Nennleistung	Nutzkühlleistung	Kältemittel	zul. Betriebsüberdruck	Temperaturbereich	Geräuschpegel	Schutzart Innenkreislauf Außenkreislauf	Abmessungen (B x H x T) mm	Gewicht	Farbton
GB	Operating voltage	Rated current	Starting current	Pre-fuse T	Duty cycle	Nom. refrigeration	Useful cooling output	Refrigerant	Permissible pressure	Temperature range	Noise level	Protection categ. Internal circuit External circuit	Dimensions (W x H x D) mm	Weight	Colour
F	Tension nominale	Courant nominal	Courant de démarrage	Dispositif de sécurité T	Durée de mise en circuit	Puissance nominale	Puissance frigorifique de rég.	Fluide frigorigène	Pression de régime autor.	Plage de température	Niveau sonore	Degré de protect. Circuit intérieur Circuit extérieur	Dimensions (L x H x P) mm	Poids	Coloris
NL	Bedrijfs-spanning	Nominale stroom	Aanloopstroom	Primaire zekering T	Inschakel-duur	Nominaal vermogen	Nuttig koelvermogen	Koel-middel	p. max.	Temperatuur-bereik	Geluids-nivo	Beschermklasse Inwendig circuit Uitwendig circuit	Afmetingen (B x H x D) mm	Gewicht	Kleur
S	Anslutnings-spanning	Mark-strom	Startström	Forsäkring gL	Inkopp-lingstid	Markeffekt	Effektiv kyl-effekt	Kylmedel	Tillåtet drifts-övertryck	Temperatur-område	Ljudnivå	Kapslingsklass Inre kretslopp Yttre kretslopp	Mått (B x H x D) mm	Vikt	Färgton
I	Tensione nominale	Corrente nominale	Corrente di spunto	Fusibili T	Ciclo d'inserzione	Potenza nominale	Potenza frigorifera utile	Fluido frigorifero	Pressione max.	Campo di temperatura	Livello di rumore	Grado di protez. Circuito interno Circuito esterno	Dimensioni (L x A x P) mm	Peso	Colore
E	Tensión de servicio	Intensidad nominal	Intensidad de arranque	Fusible T	Duración de conexión	Potencia nominal	Potencia frigorífica útil	Fluido frigorífico	Presión máxima admis.	Campo de temperaturas	Nivel de ruido	Protección Circuito interior Circuito exterior	Dimensiones (anch. x alt. x prof.) mm	Peso	Color
J	定格電圧	定格電流	起動電流	ブレーカー容量	稼働サイクル	消費電力	冷却能力	冷媒	最大圧力	使用温度範囲	ノイズレベル	保護等級 定格電圧 外部循環	外形寸法 (幅×高さ×奥行)	重量	塗装色
						L35 L35 L35 L50	DIN 3168/EN 814 L35 L35 L35 L50					EN 60 529			
SK 3296.100	230 V, 50/60 Hz	3.2 A / 3.9 A	11.4 A / 11.0 A	6 A / 6 A	100 %	330 W / 430 W 390 W / 525 W	800 W / 860 W 615 W / 685 W	R134 a, 750 g	25 bar	+ 20 – + 55 °C	62 dB (A)	IP 54 IP 34	600 x 340 x 464	38 kg	RAL 7032
SK 3296.140	400 V, 50/60 Hz	1.9 A / 2.3 A	6.6 A / 6.3 A	4 A / 4 A	100 %	345 W / 450 W 415 W / 545 W	800 W / 860 W 615 W / 685 W	R134 a, 750 g	25 bar	+ 20 – + 55 °C	62 dB (A)	IP 54 IP 34	600 x 340 x 464	41 kg	RAL 7032
SK 3272.100	115 V, 50/60 Hz	6.3 A / 6.6 A	18.2 A / 20.7 A	10 A / 10 A	100 %	345 W / 450 W 415 W / 545 W	800 W / 860 W 615 W / 685 W	R134 a, 750 g	25 bar	+ 20 – + 55 °C	62 dB (A)	IP 54 IP 34	600 x 340 x 464	41 kg	RAL 7032
SK 3290.100	230 V, 50/60 Hz	5.3 A / 6.0 A	16.6 A / 15.5 A	6 A / 10 A	100 %	710 W / 800 W 840 W / 920 W	1400 W / 1400 W 1040 W / 1200 W	R134 a, 950 g	25 bar	+ 20 – + 55 °C	62 dB (A)	IP 54 IP 44	600 x 400 x 426	44 kg	RAL 7032
SK 3290.140	400 V, 50/60 Hz	3.1 A / 3.5 A	9.6 A / 8.9 A	6 A / 6 A	100 %	740 W / 825 W 860 W / 940 W	1400 W / 1400 W 1040 W / 1200 W	R134 a, 950 g	25 bar	+ 20 – + 55 °C	62 dB (A)	IP 54 IP 44	600 x 400 x 426	50 kg	RAL 7032
SK 3280.100	115 V, 50/60 Hz	10.5 A / 12.8 A	24.6 A / 28.7 A	16 A / 16 A	100 %	740 W / 825 W 860 W / 940 W	1400 W / 1400 W 1040 W / 1200 W	R134 a, 950 g	25 bar	+ 20 – + 55 °C	62 dB (A)	IP 54 IP 44	600 x 400 x 426	50 kg	RAL 7032
SK 3256.100	230 V, 50/60 Hz	8.9 A / 9.8 A	24.7 A / 22.5 A	10 A / 10 A	100 %	1480 W / 1480 W 1590 W	2050 W / 2060 W 1490 W	R134 a, 980 g	24 bar	+ 20 – 55 °C / + 45 °C	62 dB (A)	IP 54 IP 34	600 x 454 x 460	54 kg	RAL 7032
SK 3256.140	400 V, 50/60 Hz	5.1 A / 5.7 A	14.2 A / 13.0 A	10 A / 10 A	100 %	1520 W / 1520 W 1640 W	2050 W / 2060 W 1490 W	R134 a, 980 g	24 bar	+ 20 – 55 °C / + 45 °C	62 dB (A)	IP 54 IP 34	600 x 454 x 460	59 kg	RAL 7032

Contents

1. Application
2. Technical data
3. Assembly
4. Electrical connection
5. Commencing operation and control behaviour
6. BUS System (Model No. SK 3124.000)
7. Technical information
8. Maintenance
9. Scope of supply and guarantee
10. Fault indication and fault analysis
11. Programming

1. Application

Enclosure cooling units are designed and built to dissipate heat from enclosures, by cooling the air inside the enclosure and protecting temperature sensitive components. Enclosure cooling units are particularly suitable for the temperature range of + 40°C to + 55°C.

2. Technical Data

(see table 2.1)

3. Assembly

Make 2 cut-outs and screw holes in the top of the enclosure in accordance with fig. 3.1. Prior to mounting, ensure that

- the site for the enclosure, and hence the arrangement of the cooling unit, is selected so as to ensure good ventilation;
- the location is free from excessive dirt and moisture;
- the mains connection ratings, as stated on the name plate, are available;
- the ambient temperature is no higher than + 55°C;
- the packaging shows no signs of damage. Traces of oil are an indication of coolant loss and of leakage in the unit system. Any damage to the packaging can become the cause of a subsequent function failure;
- the enclosure is sealed on all sides. Condensation will occur if the enclosure is leaky;
- the separation of the units from one another and from the wall should not be less than 200 mm;
- air inlet and outlet must not be obstructed on the inside;
- units should only be fitted vertically in the specified position. Max. deviation from true vertical: 2°;
- condensate drainage is provided (see 6.3);
- electrical connection and repair must be carried out only by authorized specialist personnel. Use only original replacement parts!
- To avoid an increase in condensation, a door operated switch (e.g. PS 4127.000) should be used which will switch the cooling unit off when the enclosure door is opened (see 5.2.3.3).

Stick the enclosed sealing gasket onto the enclosure roof.

Important: To achieve a permanent seal between the cooling unit and the enclosure, the mounting surface may have to be strengthened or supported (see example on PS 3256...., fig. 3.2).

Accessories for roof plate stiffening on the PS:

- Mounting rail
- "U" nut
- Fixing bracket
- Threaded block

SK 3290.... / 3280.... / 3296.... / 3272.... – 6 x M6 SK 3256.... – 8 x M8 screw setscrews into the blind nuts on the underside of the unit and fix the unit with washers and nuts from underneath. For transportation of unit by crane: remove the blanking plug and screw in an eyebolt M12.

4. Electrical Connection

The connected voltage and frequency must correspond to the values stated on the name plate. The cooling unit must be connected to the mains via an isolating device, which ensures at least 3 mm contact opening when switched off. The unit must not have any additional temperature control connected before it. Line protection should be provided by means of the pre-fuse specified on the name plate. Observe the relevant regulations during installation!

Version100

Connection should be made to the cable attached to the unit (see Detailed Wiring Diagram).

Version500

Connect the mains connection to the plug-in terminal strip X 10 (see Wiring Diagram).

- Door limit switch, see 5.2.3.3
- Collective fault signal connection, see 5.2.3.1
- Note the designations on the terminal strip (see Wiring Diagram).
- The unit must be disconnected prior to checking the protective earth conductor, high voltage and the insulation in the enclosure.

5. Commencing Operation and Control Behaviour

Following the completion of mounting and a waiting period of approximately 30 minutes (to allow oil to collect in the compressor in order to ensure lubrication and cooling) electrical connection can be made.

5.1 Control by Thermostat

Version100

The cooling unit operates automatically, i.e. following the electrical connection, the evaporator fan will run continuously to circulate the air inside the enclosure. This provides a uniform temperature distribution in the enclosure. The built-in temperature controller (setting the desired internal temperature) effects automatically controlled switch-off of the cooling unit by the value of the fixed switching difference setting of 5 K. This is set at the factory to + 35°C.

5.1.1 Temperature Setting at the Controller

Fig. 5.1 Thermostat

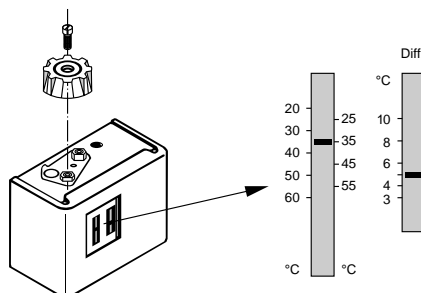

Set the desired temperature. Setting range + 20°C to + 55°C.

To avoid cyclic operation of the compressor, it is imperative that the set switching difference of 5 K is not changed and does not deviate to a lower value.

5.2 Control by Microcontroller

Version500

Fig. 5.2 Microcontroller

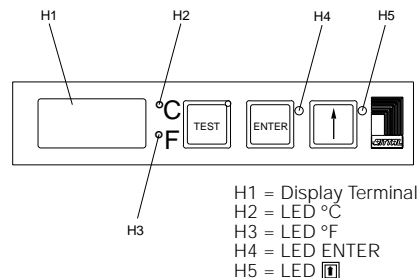

- H1 = Display Terminal
- H2 = LED °C
- H3 = LED °F
- H4 = LED ENTER
- H5 = LED

After electrical connection the internal fan turns on and circulates the enclosure air. This helps assure even temperature distribution within the enclosure. The condenser fan and compressor are controlled by the microcontroller. The minimum run time is 90 seconds. The switching difference is 5 – 10 K and is set at the factory. In order to maximize energy efficiency the thermostat should be set to the highest enclosure temperature as allowed by the electronics.

5.2.1 Operation of the Microcontroller

The display terminal H1 consists of a 3 position 7-segment display which indicates the enclosure internal temperature in °C or °F (changeable, see section 5.2.2) as well as any fault codes. The actual enclosure internal temperature is constantly displayed. If a fault occurs then the fault number is indicated in the left position. When programming the microcontroller the program level and parameter value is indicated on the display. When the "TEST" button is pushed the compressor and the fans will run for 5 minutes regardless of the internal temperature or door limit switch. This allows for a system test after an extended shutdown period (e.g. after the winter).

5.2.2 Programming

In the EEPROM of the microcontroller various parameters are stored which can be changed through using the "ENTER" and buttons, 9 different parameters are changeable as outlined in table 5.1. To access the programming mode push both the "ENTER" and buttons simultaneously for 10 seconds. The left digit will then indicate the program level and the LED for the "ENTER" and buttons will blink. By pushing the button the program level can be advanced to the next level. In order to access levels 5 through 9 a security code must be entered. If no buttons are pushed for 60 seconds the display will return to the standard mode which displays the enclosure temperature. Programming of the parameters is made easy with diagram 5.1 on page 35. A description of the parameters to be programmed can be found in table 5.1. All parameters are stored in the EEPROM and are retained when power is shut off to the air conditioner.

5.2.3 Fault Signalling Facility

All faults on the cooling unit are registered and indicated by H1 as a fault number. The display is by means of the left-hand number. The display cycles through all pending fault messages in a 2 second cycle, starting with the internal temperature of the enclosure.

- H1 indicates the following faults as a fault number:
- 1 = Enclosure internal temperature too high (5 K above setpoint value)
 - 2 = Current monitor, condenser
 - 3 = Evaporator (no collective fault indication)
 - 4 = High-pressure monitor
 - 5 = Current monitor, condenser fan
 - 6 = Current monitor, evaporator fan
 - 7 = Filter mat soiled
 - 8 = Temperature sensor cable break/short-circuit

5.2.3.1 Fault Signal Contact (K1, potential-free)

The fault signal relay is pulled in at normal condition. Any faults will cause the relay to drop out (except low-pressure monitor, fault number 3). Any failure of the control voltage will also lead to drop-out of the relay and can thus be registered. The connection is made on the terminal strip X10. For contact data and assignment, see wiring diagram.

5.2.3.2 Filter Mat Monitoring

The specified filter mat has large pores and filters coarse dust and lint from the air. Oil condensate is partially separated out. Fine dust is drawn through the filter mat and the external circuit of the unit due to the high suction power of the fan. It does not have any damaging effect on the function of the unit.

Fig. 5.3 Filter Mat Replacement

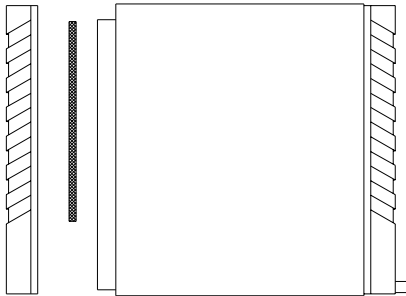

Function of the Filter Mat Monitor:

The filter mat is monitored for soiling by measuring the temperature difference in the external circulation of the cooling unit. In the event of any filter mat soiling, the temperature difference will increase. The setpoint value of the temperature difference in the external circulation is adapted to various air conditioner operating conditions. This eliminates the need for subsequent adjustment of the setpoint value for different operating points of the unit. (For the setting of the filter mat replacement see table 5.1 and fig. 5.1.)

5.2.3.3 Door Limit Switch S2 (supplied by customer)

Where a door limit switch is used and the enclosure door is open (contact is closed when door is open), the cooling unit (fans and condenser) will switch off after approx. 10 s, thereby avoiding an increase in condensation while the door is open. To avoid cyclic operation, switch-on of condenser and external fan is delayed by about 3 minutes after the door has been closed. The internal fan will start up immediately on closure of the door. Connection is made at the terminal strip X10, terminals 1 and 2. The extra low voltage is supplied by the internal power pack, current is approx. 30 mA DC (no extra low safety voltage). Connect the door limit switch free from potential only, no external voltage! The display will flash during the door delay time. The system message "1010" is transmitted via the PLC interface.

5.2.3.4 PLC Interface X2 (Option)

The interface is used for the transmission of the actual internal temperature of the enclosure and any system messages of the cooling unit to the PLC. The transmitted information can be displayed by means of the output facilities (e.g. plain text display) which are connected to the PLC, or by means of the serial interface to a higher order computer.

Construction of the PLC interface:

The construction is potential separated via optocoupler (wiring diagram fig. 5.4). Connection is made by the customer to the 15-pin socket on the control board (fig. 5.4) to the PLC input card.

Attention!

The electrical signals at the interface are of an extra-low voltage (not extra-low safety voltages according to EN 60335).

Fig. 5.4 PLC Interface

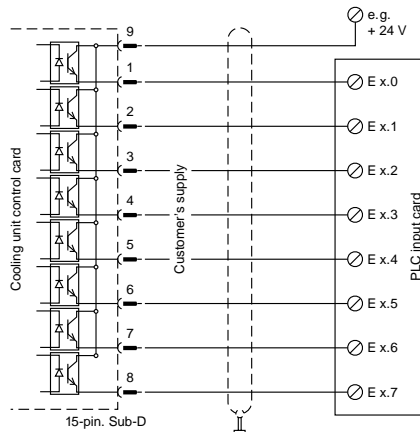

Max. loading of the outputs:
30 V/10 mA, direct current
Connection: screened 15-core control cable.
The possibility exists to access this information over the PLC interface (level 8, table 5.1 or fig. 5.1).

a) Standard mode (Level 8 = "0")

Communication of the enclosure internal temperature and of the fault messages is made successively in 2 s cycle. Since this is an 8-bit parallel transmission, input signals should not be accepted as valid in the PLC until they have been present for 0.5 s. This ensures that no invalid input information will be evaluated in the event of signal changes at the inputs.

Fig. 5.5 PLC Interface X2 Pulse/time diagram (example)

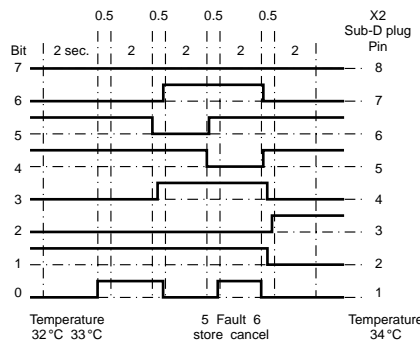

Enclosure internal temperature:
Transmission with 2 digits in BCD format



System messages:

The system messages are transferred by means of identification (4 bit) and a fault number (1 digit BCD). The identification is structured as follows:

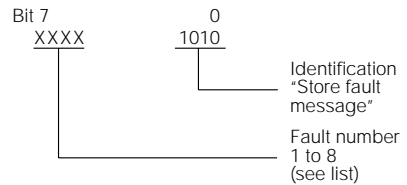

In the event of a fault XXXX (BCD), the identification is transmitted cyclically. This information can be used to store the fault message in the PLC.

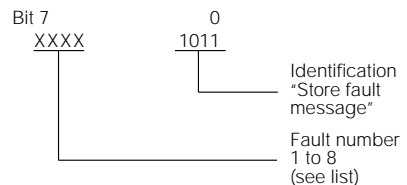

This identification is transferred once, as soon as the fault with the number XXXX/BCD has been rectified. This information can be used to delete the fault message in the PLC.

Evaluation of the interface signals in the PLC:
Messages:

If bit 1 and bit 3 of the input byte have a 1 signal, the transmitted information is a system message. In this case, the meaning of bit 0 is either the information "store fault message" (bit 0 = 0) or "cancel fault message" (bit 0 = 1). Bit 4 to 7 represent the appropriate message number (BCD).

Temperature:

If the AND operation of bit 1 and bit 3 is not fulfilled, the input information represents the actual internal temperature of the enclosure. In this case, both BCD digits have valid values (< 9).

b) Parallel fault codes (Level 8 = "1")

This can be accessed as follows:

Every one of the eight outputs stands for a certain system message (see below). It is not possible to display the internal temperature at the same time as the system messages.

Output/Bit	System Message
0	Max. enclosure internal temperature
1	Filter mat soiled
2	Enclosure door is open
3	High-pressure monitor
4	Evaporator
5	Current monitor, compressor
6	Current monitor, internal fan
7	Current monitor, external fan

Because these fault codes are transmitted through an optocoupler, they can be switched to a parallel transmission.

6. BUS System

(Model No. SK 3124.000)

6.1 General

The BUS system allows a maximum of 7 cooling units to be interconnected. As a result, the following functions are available to the operator:

- Parallel unit control (the cooling units in the network can be simultaneously switched on and off).
- Parallel door status messages ("door open").
- Collective fault message.

The data exchange is carried out using cables (shielded two-wire leads). All units are assigned an address. This address also includes the ID for "Master" or "Slave". The BUS system cannot be used to link the cooling units to a PC.

The PLC interface is switched to parallel error encoding.

NOTE

The following restrictions must be heeded: only 6 outputs (0 to 5) are available; outputs 5, 6 and 7 are routed in parallel to output 5.

6.2 Notes Regarding Installation

ATTENTION!

The electrical signals at the interface are of an extra-low voltage (not extra-low safety voltages according to EN 60335). Always heed the following notes!

- De-energise the cooling units to be connected.
- Ensure proper electrical insulation.
- Make sure the cables are not laid in parallel to power lines.
- Make sure that the lines are short.

6.3 Programming the Cooling Unit

See diagram 5.1 for details on programming.

IDs:

Master cooling unit		Slave cooling unit	
00	Basic state	00	Basic state
01	Master with 1 slave	11	Slave with address 1
02	Master with 2 slaves	12	Slave with address 2
03	Master with 3 slaves	13	Slave with address 3
04	Master with 4 slaves	14	Slave with address 4
05	Master with 5 slaves	15	Slave with address 5
06	Master with 6 slaves	16	Slave with address 6

NOTE

Only one unit may be configured as master; the address ID must match the number of slave units. The individual slave units must have different addresses; the addresses must be in ascending order (without gaps in between).

Example:

1 master cooling unit with 2 slave cooling units

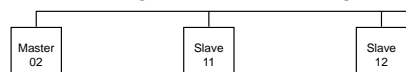

7. Technical Information

The cooling unit (compression refrigeration unit) consists of four main components: the coolant compressor, evaporator, condenser, and the control or expansion valve, which are connected by suitable pipework. This circuit is filled with a readily boiling substance, the coolant. The R134a (CH₂FC₂) coolant is free from chlorine. It has an ozone destroying potential (ODP) of 0 and is therefore environmentally friendly. A filter dryer which is integrated in the hermetically sealed cooling circuit, provides effective protection against moisture, acid, dirt particles, and foreign bodies within the cooling circuit.

7.1 Operation of the Cooling Unit

Fig. 7.1 Cooling circuit

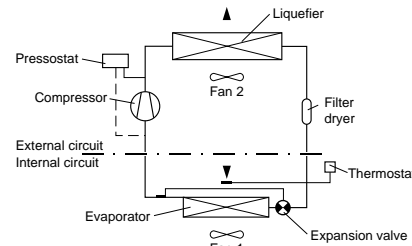

When a coolant compressor is put into operation, the coolant vapour evaporates from the evaporator. The heat required for the evaporation of the coolant is drawn from the evaporator environment (internal circuit of the enclosure), causing it to cool down. The heat fed to the coolant in the evaporator is its environment (assisted by fans), making the coolant once more liquid due to the condensation which takes place. In the thermostatically controlled expansion valve, the liquid coolant is reduced to the particular evaporator pressure required.

The cooling which occurs due to the reduction of pressure, releases the heat from the liquid, which evaporates part of the coolant flow.

The mixture of cold liquid and throttle vapour is returned to the evaporator. The cooling cycle is thus completed, the aforementioned process of the heat transfer starts afresh.

7.2 Safety Equipment

The cooling circuit of the cooling unit embodies a component tested high-pressure monitor to VBG 20.7.1 which is set to maximum operating pressure and operates via an automatic reset device at recurring pressure drop. Temperature and low-pressure monitoring will prevent the evaporator from icing up. If there is a risk of icing up, the condenser is switched off and automatically switched on again at higher temperatures. The coolant compressor and the fans are equipped with thermal winding protection against excess current and excess temperature.

7.3 Condensate Discharge

1. To drain away any incidental condensate, attach a discharge hose to the 12 mm by SK 3296.100 / 3296.500 / 3272.100 and 15 mm by SK 3290.100 / 3290.500 / 3280.100 pipe connection piece, which protrudes from the unit. Connect the drain hose to the angled connection piece (1) (avoiding any kinks) and route the hose directly downwards in order to prevent any backflow and overflow of the condensate inside the unit.

2. To prevent external air flowing through the condensate discharge connection piece into the interior of the enclosure, fit the enclosed backflow preventer (2) in the drain hose.

The nonwoven fabric inserted in the backflow preventer ensures safe drainage of the condensate.

The backflow preventer may become contaminated over a period of time and should be examined at least once per annum and replaced as necessary.

Fig. 7.3 Condensate Discharge

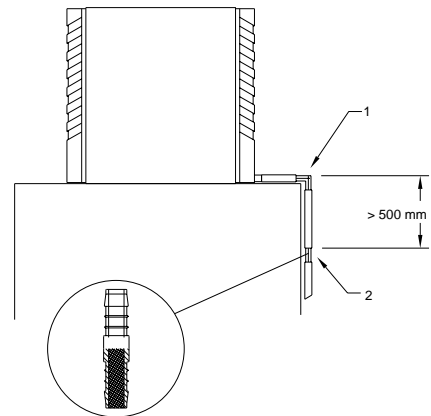

7.4 General

Storage temperature: The cooling units must not be subjected to temperatures above + 70°C during storage. Transport attitude: The cooling units must always be transported upright. Waste disposal: The closed cooling circuit contains coolant and oil which must be correctly disposed of for the protection of the environment. The disposal can be carried out at Rittal-Werk. Technical modifications reserved.

8. Maintenance

As a maintenance-free, hermetically sealed system, the cooling circuit has been filled in the factory with the required amount of coolant, and tested for leaks and subjected to a function trial run. The installed maintenance-free fans use ball bearings, they are protected against moisture and dust, and are fitted with a temperature monitor. The life expectancy is at least 30,000 operating hours. The cooling unit is thus largely maintenance-free.

All that may be required from time is that the components of the external air circuit are cleaned by compressed air. The use of a filter mat is recommended only if large particles of lint are present in the air, so that blockage of the condenser is prevented.

(Filter mat replacement, fig 5.3)

Caution: Prior to any maintenance work, the power to the cooling unit must be disconnected.

9. Scope of Supply and Guarantee

1 cooling unit, ready for connection

1 sealing gasket

1 eyebolt M12

1 angled hose fitting

1 backflow preventer

6 setscrews M6 x 30

6 washers A 8.4

6 nuts M6

8 setscrews M8 x 40 (SK 3256...)

8 washers A 8.4 (SK 3256...)

8 nuts M8 (SK 3256...)

1 drilling template

1 set of mounting and operating instructions

1 3-pole plug

(SK 3296.100 / 3272.100 / 3280.100)

1 5-pole plug (SK 3290.500)

Guarantee:

This unit is covered by a 1-year guarantee from the date of supply, subject to correct usage. Within this period, the returned unit will be repaired in the factory or replaced free of charge. The cooling unit is to be used for the cooling of enclosures only. If it is connected or handled improperly the manufacturer's guarantee does not apply and in this case we are not liable for any damage caused.

10. Fault Indication and Fault Analysis:

Fault No.	Nature of Fault	Cause	Remedy
1	Temperature inside the enclosure too high	Cooling output too low (lack of coolant) Consequential fault or faults 2 – 7	Check cooling output Carry out cooling service
2	Compressor	Compressor overloaded (internal winding protection)	Unit will switch on automatically
		Defect (check by measuring the resistance of the winding)	Replace as part of cooling service
		Relay or feed cable faulty	Replace power PCB
3	Evaporator	Operational indication if risk of icing up exists	Raise the setpoint value of the internal temperature of enclosure
		Lack of coolant	Carry out of cooling service
4	High-pressure monitor	Ambient temperature too high	Unit's specified range of application exceeded
		Condenser contaminated	Clean
		Filter mat contaminated	Clean or replace
		Condenser fan defective	Replace
		"E" valve defective	Carry out of cooling service
		Defective	Replace as part of cooling service
5	Condenser fan	Blocked or defective	Replace
6	Evaporator fan	Blocked or defective	Replace
7	Filter monitoring	Filter mat contaminated	Clean or replace
8	Temperature sensor	Cable break or short-circuit	Replace
9	Phase monitoring	Incorrect field of rotation	Reverse two phases

11. Programming (tab. 5.1)

Program Level	Changeable Parameter	Min. Value	Max. Value	Factory Setting	Description
1	Internal enclosure temperature T_i	30	45	35	The standard thermostat setting range is 35 – 45°C. The upper and lower limits can be adjusted through programm level 5 and 6.
2	Set value of filter mat monitor	4	40 (99 = off)	99	Factory setting is the shut off value (99). To activate: 1. Install clean filter mat and let air conditioner cool for a few minutes. 2. Select programm level 2. 3. Push test button 10 seconds. Temperature difference is displayed. 4. Using the "▲" button adjust the temperature 2 – 3 K above the displayed value.
3	Imperial/metric units °C/°F	0	1	0	The enclosure temperature can be displayed in both °C and °F.
4	Security code			123	In order to access program levels 5 – 9 the code "123" must first be entered through program level 4.
5	Minimum thermostat setting	20	35	30	The minimum thermostat setting can be adjusted from 35°C to 20°C.
6	Maximum thermostat setting	40	55	45	The maximum thermostat setting can be adjusted from 40°C to 55°C.
7	Alarm setting for enclosure temperature	3	15	5	Due to the standard factory setting of 5 K the fault code 1 is displayed when the enclosure temperature is 5 K or more above the thermostat setting. This "alarm temperature" setting can be adjusted from 3 to 15°C.
8	Setting of PLC interface	0	1	0	The factory setting is for serial interface. Parallel interface is activated by selecting 1.
9	Turn off of evaporator fan	0	1	0	With the factory setting the evaporator fan turns off for 1 minute each time the unit cycles. This helps condensate drainage. This feature can be turned off by changing the setting to 1.

D Anschlußschema Microcontroller

A1	= Leistungsplatine
A2	= Anzeigeterminal
B1	= Temperaturfühler Innentemperatur
B2	= Temperaturfühler Vereisungsschutz
B3	= Temperaturfühler außen 1
B4	= Temperaturfühler außen 2
C1-C3	= Betriebskondensatoren
F1	= Thermostat
F2	= Pressostat
F3	= Thermischer Wicklungsschutz
K1	= Relais Sammelstörung
M1	= Verdichter
M2	= Verflüssigerventilator
M3	= Verflüssigerventilator
M4	= Verdampferventilator
S2	= Türendschalter (ohne Türendschalter Klemme 1, 2 offen)
T1	= Transformator (SK 3272.100 / 3280.100 und Sondergeräte)

Kundenseitiger Anschluß:

X2	= SPS-Schnittstelle (Sub-D-Buchse 15pol.)
X10	= Anschlußklemmleiste
X10	= L1, L2/N, PE = Netzanschluß
X10	= 1, 2 = Türendschalteranschluß (Kundenbeistellung)
X10	= 3, 4, 5 = Sammelstörung

NL Aansluitschema mikro-controller

A1	= Hoofdstroomprint
A2	= Display
B1	= Temperatuursensor interne temp.
B2	= Temperatuursensor ijsvorming
B3	= Temperatuursensor buiten 1
B4	= Temperatuursensor buiten 2
C1-C3	= Motorkondensator
F1	= Termostaat
F2	= Pressostaat
F3	= Thermische beveiliging van de wikkeling
K1	= Relais verzamelstoring
M1	= Kompressor
M2	= Kondensatorventilator
M3	= Kondensatorventilator
M4	= Verdampventilator
S2	= Deurschakelaar (zonder deur- schakelaar klem 1, 2 open)
T1	= Transformator (SK 3272.100 / 3280.100 en speciale app.)

Elektrische aansluiting door klant:

X2	= PLC-interface (Sub-D-konnektoer 15-polig)
X10	= Klemmenstrook
X10	= L1, L2/N, PE = netaansluiting
X10	= 1, 2 = aansluiting deurschakelaar (door klant te installeren)
X10	= 3, 4, 5 = algemene storingsindicatie

E Esquema de conexiones del microprocesador

A1	= Pletina de potencia
A2	= Pantalla indicadora
B1	= Sonda térmica de la temp. en el interiore del armario
B2	= Sonda térmica protección contra congelación
B3	= Sonda térmica exterior 1
B4	= Sonda térmica exterior 2
C1-C3	= Condensador electrolítico de servicio
F1	= Termostato
F2	= Presostato
F3	= Protección térmica del devanado
K1	= Relé de fallo
M1	= Compresor
M2	= Ventilador del condensador
M3	= Ventilador del condensador
M4	= Ventilador del evaporador
S2	= Interruptor de puerta (sin interruptor final borne 1, 2 abierto)
T1	= Transformador (SK 3272.100 / 3280.100 y aparatos especiales)

Connexión por parte del cliente:

X2	= Interfase de la LCP (base casquillo D-sub 15 pol.)
X10	= Regleta de bornes
X10	= L1, L2/N, PE = Conexión de red
X10	= 1, 2 = Bornes de conexión del interruptor final de carrera S 2, cierre puerta
X10	= 3, 4, 5 = Bornes de conexión (señal avería)

GB Wiring Diagram Microcontroller

A1	= Power PCB
A2	= Display Terminal
B1	= Temperature sensor, internal temp.
B2	= Temperature sensor, risk of icing
B3	= Temperature sensor, external 1
B4	= Temperature sensor, external 2
C1-C3	= Operating capacitors
F1	= Thermostat
F2	= Pressostat
F3	= Thermal winding protection
K1	= Relay collective fault
M1	= Compressor
M2	= Condenser fan
M3	= Condenser fan
M4	= Evaporator fan
S2	= Door limit switch (without door operated switch terminal 1, 2 open)
T1	= Transformer (SK 3272.100 / 3280.100 and special units)

Electrical Connection by Customer:

X2	= PLC interface (Sub-D-socket, 15-pole)
X10	= Terminal strip
X10	= L1, L2/N, PE = Mains connection
X10	= 1, 2 = Door operated switch connection (supplied by customer)
X10	= 3, 4, 5 = Collective fault message

S Anslutningsschema microcontroller

A1	= Drivkort
A2	= Display terminal
B1	= Temperaturgivare innertemperatur
B2	= Temperaturgivare nedisningsrisk
B3	= Temperaturgivare yttre 1
B4	= Temperaturgivare yttre 2
C1-C3	= Startkondensator
F1	= Termostat
F2	= Pressostat
F3	= Termiskt lindningssskydd
K1	= Samlingsrelä felsignaler
M1	= Kompressor
M2	= Kondensorfläkt
M3	= Kondensorfläkt
M4	= Förångarfläkt
S2	= Dörrströmbrytare (utan dörrström- brytarklämma 1, 2 öppna)
T1	= Transformator (SK 3272.100 / 3280.100 och specialaggregatet)

Ansluts av kund:

X2	= PLC-ingång (D-Sub-utdrag 15-pol)
X10	= kopplingsplint
X10	= L1, L2/N, PE = nätanslutning
X10	= 1, 2 = anslutning dörrkontakt (måste beställas separat)
X10	= 3, 4, 5 = samlingsstörnings-anslutning

F Schéma électrique Microprocesseur

A1	= Platine de puissance
A2	= Display Terminal
B1	= Sonde de température, température intérieure
B2	= Temp. sensor danger de givrage
B3	= Sonde de température extérieure 1
B4	= Sonde de température extérieure 2
C1-C3	= Condensateur de régime
F1	= Régulateur de température
F2	= Pressostat
F3	= Protection de bobinage thermique
K1	= Relais perturbations
M1	= Compresseur
M2	= Ventilateur du condenseur
M3	= Ventilateur du condenseur
M4	= Ventilateur de l'évaporateur
S2	= Interrupteur de porte (sans contacteur les bornes 1, 2 sont ouvertes)
T1	= Transformateur (SK 3272.100 / 3280.100 et les appareils spéciales)

Electrical Connection by Customer:

X2	= Interface SPS (douille Sub-D 15 pôles)
X10	= Borne plate de raccordement
X10	= L1, L2/N, PE = Raccordement au réseau
X10	= 1, 2 = Raccordement de l'interrupteur de porte (à monter par le client)
X10	= 3, 4, 5 = Connexion de la signalisation de défaut

I Schema allacciamenti microcontrollore

A1	= Scheda di potenza
A2	= Display terminale
B1	= Sonda temperatura interna
B2	= Sonda temperatura, pericolo di formazione di ghiaccio
B3	= Sonda temperatura esterna 1
B4	= Sonda temperatura esterna 2
C1-C3	= Condensatore d'esercizio
F1	= Termostato
F2	= Pressostato
F3	= Protezione termica avvolgimento
K1	= Relè segnalatore guasti
M1	= Compressore
M2	= Ventilatore del condensatore
M3	= Ventilatore del condensatore
M4	= Ventilatore dell'evaporatore
S2	= Interruttore della portina (senza inter- rutture i morsetti 1, 2 sono aperti)
T1	= Trasformatore (SK 3272.100 / 3280.100 e apparecchi speciali)

Connessioni elettriche a cure del cliente:

X2	= Interfaccia PLC (presa 15 poli)
X10	= Morsettiera d'allacciamento
X10	= L1, L2/N, PE = Allacciamento rete
X10	= 1, 2 = Allacciamento interruttore fine corsa della portina (forn. dal cliente)
X10	= 3, 4, 5 = Segnalatore comune disturbi

Wirkschluplan

Detailed Wiring Diagram

Schéma des connexions détaillé

Werkingschema

SK 3296.100
SK 3296.140
SK 3272.100

Driftschema

Schema d'allacciamento

Esquema de funcionamiento

配線図

Technische Daten siehe Typenschild
Technical data see name plate

* nur bei Trafoeinbau
* only if transformer is installed

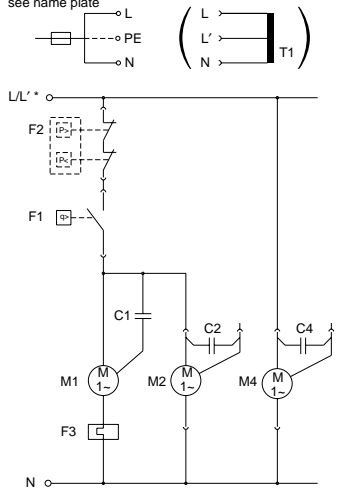

Wirkschluplan

Detailed Wiring Diagram

Schéma des connexions détaillé

Werkingschema

SK 3290.100
SK 3290.140
SK 3280.100

Driftschema

Schema d'allacciamento

Esquema de funcionamiento

配線図

Technische Daten siehe Typenschild
Technical data see name plate

* nur bei Trafoeinbau
* only if transformer is installed

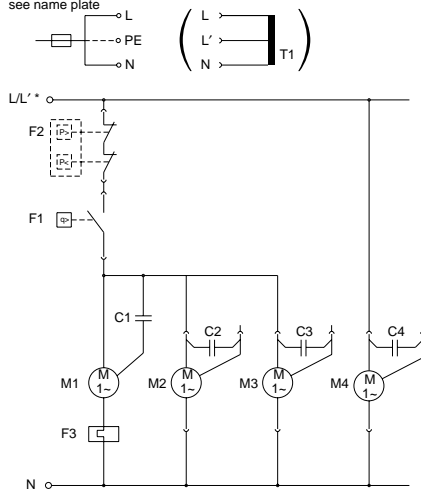

Anschlußschema

Wiring Diagram

Schéma électrique

Aansluitschema

Anslutningsschema

Schema allacciamenti

Esquema de conexiones

接続図面

SK 3296.500
SK 3296.540
SK 3290.540
SK 3256.500
SK 3256.540

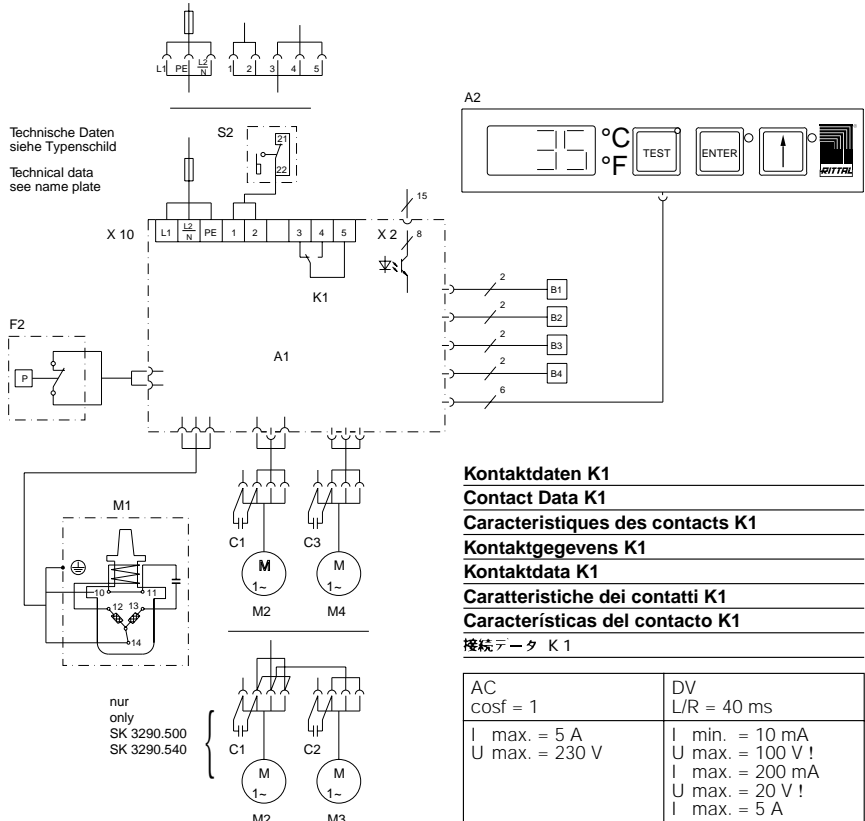

Technische Daten siehe Typenschild
Technical data see name plate

Kontakt Daten K1
Contact Data K1
Caracteristiques des contacts K1
Kontaktgegevens K1
Kontaktdata K1
Caratteristiche dei contatti K1
Características del contacto K1
接続データ K1

AC cosφ = 1	DV L/R = 40 ms
I max. = 5 A	I min. = 10 mA
U max. = 230 V	U max. = 100 V !
	I max. = 200 mA
	U max. = 20 V !
	I max. = 5 A

Wirkschluplan

Detailed Wiring Diagram

Schéma des connexions détaillé

Werkingschema

SK 3256.100
SK 3256.140

Driftschema

Schema d'allacciamento

Esquema de funcionamiento

配線図

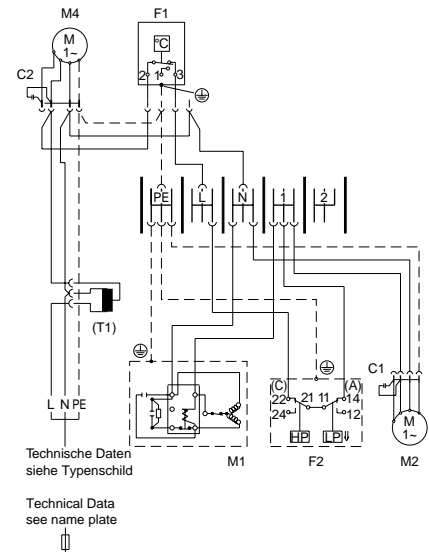

Technische Daten siehe Typenschild
Technical Data see name plate

Position Item Pos. Pos. Pos. Posición	Ersatzteil- liste	Spares List	Liste de pièces détachées	Lijst reserve- delen	Reserv- delslista	Lista dei pezzi di ricambio	Lista de piezas de repuesto	
	D	GB	F	NL	S	I	E	J
	Bezeichnung	Description	Signification	Benaming	Beteckning	Descrizione	Descripción	
1	Kompressor	Compressor	Compresseur	Compressor	Kompressor	Compressore	Compresor	
2	Anlaufvorrichtung	Starting device	Dispositiv de démarrage	Startinrichting	Startanordning	Dispositivo di avviamento	Dispositivo de arranque	
5	Verflüssiger-ventilator	Condensing fan	Soupape du condenseur	Condensor-ventilator	Kondensorfläkt	Ventilatore del condensatore	Ventilador del condensador	
10	Verdampfer-ventilator	Evaporator fan	Soupape de l'évaporateur	Verdampfer-ventilator	Förångarfläkt	Ventilatore dell'evaporatore	Ventilador del evaporador	
15	Versandbeutel	Dispatch bag	Pochette d'accessoires	Zakje toebehoren	Tillbehörspåse	Sacchetto accessori	Bolsa de accesorios	
20	Expansionsventil	Expansion valve	Soupape de détente	Expansieventiel	Expansionsventil	Valvola d'espansione	Válvula de expansión	
25	Filtertrockner	Filter dryer	Assècheur de filtre	Filterdroger	Filtertork	Filtro essicatore	Secador del filtro	
30	Pressostat	Pressostat	Pressostat	Pressostaat	Pressostat	Pressostato	Presostato	
35	Thermostat	Thermostat	Thermostat	Thermostaat	Thermostat	Termostato	Termostato	
40	Microcontroller-Box	Microcontroller box	Micro-processeur box	Microcontroller E-box	Microkontroll box	Box Microcontroller	Carcasa microcontrolador	
45	Lamellengitter 2	Louvred grille 2	Grille à lamelles 2	Rooster 2	Lamellgitter 2	Griglia a lamelle 2	Rejilla 2	
46	Lamellengitter 1	Louvred grille 1	Grille à lamelles 1	Rooster 1	Lamellgitter 1	Griglia a lamelle 1	Rejilla 1	
50	Abdeckblende	Infill panel	Couvercle	Afdekkplaat	Täckplåt	Copertura cieca	Pantalla cubierta	
55	Anzeigeplatine	Display PCB	Platine d'indication	Displayprint	Displaykort	Scheda di comando	Pletina de indicación	
60	Displayaufnahme	Display support	Support de platine	Display	Displayram	Alloggiamento Display	Display	
65	Folientastatur	Membrane keyboard	Clavier à effleurement	Folietoetsenbord	Folie tryckkrappar	Tastiera a membrana	Teclado de membrana	
66	Abdeckfolie	Covering membrane	Feuille de recouvrement	Afdeckfolie	Täckfolie	Lamina di copertura	Lámina cubierta	
70	Temperaturfühler, Vereisung	Icing sensor	Sonde de givrage	Aanwijzings-sensor	Nedslings-givare	Sonda riferimento	Sensor referencial	
71	Temperaturfühler	Temperature sensor	Sonde de température	Temperatuur-sensor	Temperaturgivare	Sonda di temperatura	Sonda térmica	
75	Haube	Cover	Couvercle	Afdekkap	Huv	Calotta	Capucha	
80	Transformator	Transformer	Transformateur	Trafo	Trafo	Trasformatore	Transformador	
85	Tropfenabscheider	Mist collector	Paregouttes	Lekbok	Kondensvatten anskiljare	Separatore gocce	Colector de gotas	
90	Verdampfer	Evaporator	Evaporateur	Verdamper	Kondensor	Evaporatore	Evaporador	
100	Verflüssiger	Condenser	Condenseur	Condensor	Förångar	Condensatore	Condensador	

SK 3256....

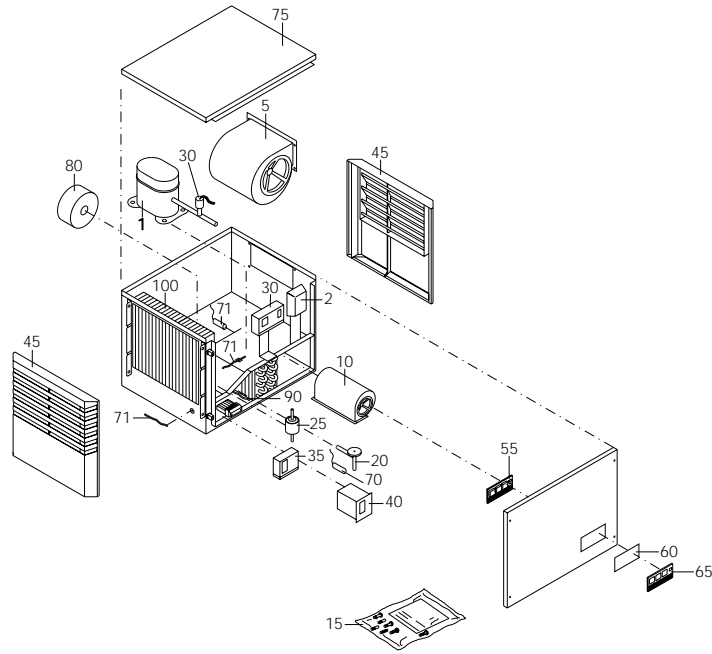

SK 3296.... / 3272.100

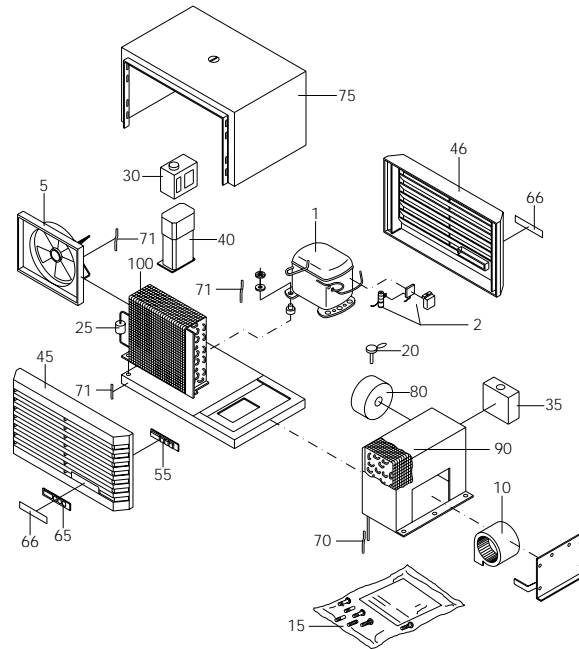

SK 3290.... / 3280.100

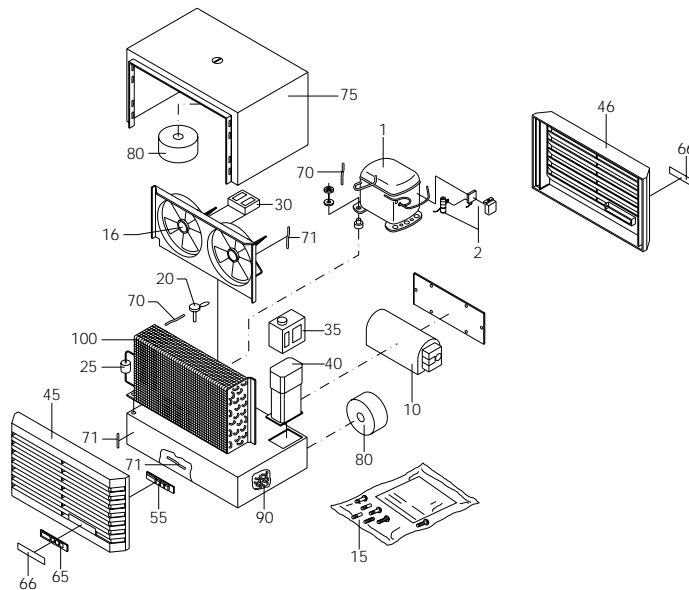

Kennlinienfeld (DIN 3168)

Performance Diagram

Diagramme des lignes caractéristiques

Karakteristiek

Karakteristik kurva

Diagramma delle curve caratteristiche

Diagrama de potencia

冷却能力線図

\dot{Q}_k = Dauer-Nutzkühlleistung (W)
Cooling output
Puissance frigorifique utilisée
Nuttig koelvermogen
Kyleffekt
Potenza frigorifera utile
Potencia útil de refrigeración
冷却能力

T_i = Schaltschrank-Innentemperatur (°C)
Enclosure internal temperature
Temperature a l'intérieur de l'armoire
Temperatuur in de kast
Temperatur inne i skåpet
Temperatura interna dell'armadio
Temperatura interior del armario de mando
内部温度 (蒸発器入口温度)

Kennlinienfeld SK 3296... / 3272.100 (DIN 3168) (50 Hz)

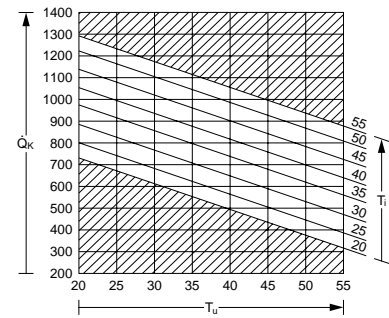

Kennlinienfeld SK 3256... (DIN 3168) (50 Hz)

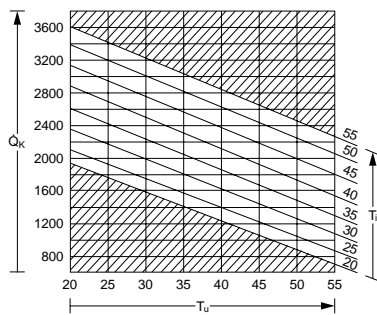

T_u = Umgebungstemperatur (°C)
Ambient temperature
Température ambiante
Omgevingstemperatuur
Omgivningstemperatur
Temperatura ambiente
Temperatura ambiente
外部温度 (凝縮器入口温度)

Kennlinienfeld SK 3290... / 3280.100 (DIN 3168) (50 Hz)

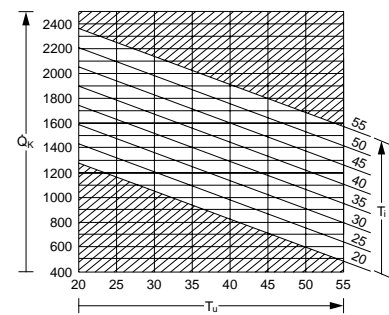

Kennfeld Leistungsaufnahme

Performance Input Diagram

Puissance absorbée

Karakteristiek vermogensopname

Karakteristik kurva ineffekt

Diagramma delle potenze assorbite

Diagrama de absorción de potencia

消費電力線図

P_{ei} = Leistungsaufnahme (kW)
Performance entry
Puissance absorbée
Vermogensopname
Ineffekt
Potenza assorbita
Absorción de potencia
消費電力

T_i = Verdampfeintritt (°C)
Evaporator entry
Entrée de l'évaporateur
Verdampferinlaat
Förångaringång
Ingresso evaporatore
Entrada del evaporador
内部温度 (蒸発器入口温度)

Kennfeld Leistungsaufnahme SK 3296... / 3272.100 (DIN 3168) (50 Hz)

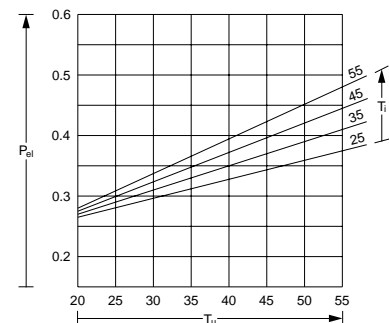

Kennfeld Leistungsaufnahme SK 3256... (DIN 3168) (50 Hz)

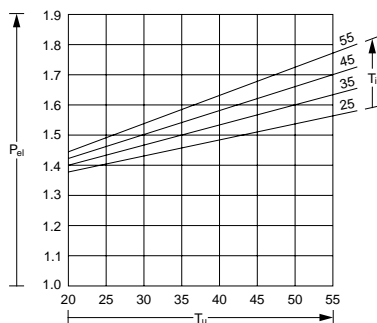

T_u = Verflüssigereintritt (°C)
Liquifier entry
Entrée du condenseur
Kondensatorinlaat
Kondensoringång
Ingresso condensatore
Entrada del condensador
外部温度 (凝縮器入口温度)

Kennfeld Leistungsaufnahme SK 3290... / 3280.100 (DIN 3168) (50 Hz)



Diagramm 5.1: Programmierung

Diagram 5.1: Programming

Diagramme 5.1: Programmation

Diagram 5.1: Programming

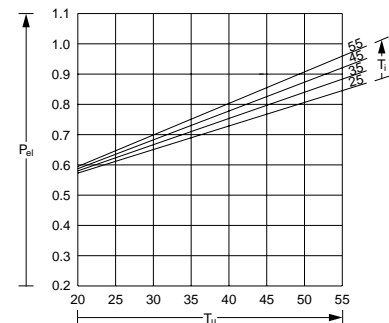
Diagramma 5.1: Programmazione

Diagrama 5.1: Programación

ダイヤグラム 5.1: プログラミング

