

# Backlash-free Metal Bellow Coupling Series AK with conical hub

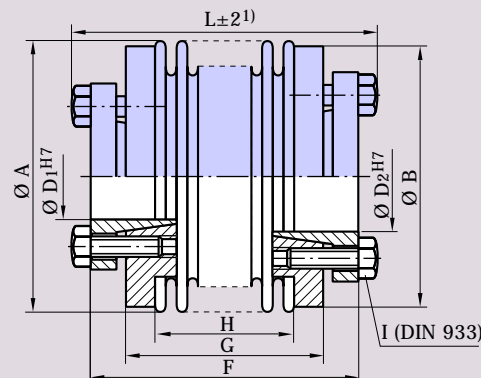

## Technical data series AK

Type	30	60	80	150	200	300	500	800	1400	3000	5000
Nominal torque (Nm) $T_{KN}$	30	60	80	150	200	300	500	800	1400	3000	5000
Torsional stiffness ( $10^3$ Nm/rad) $C_{Tdyn}$	35/25	75/50	130/75	150/100	170/120	500/280	310	760	1300	2800	4800
Radial spring stiffness (N/mm) $C_r$	720/220	1100/330	1200/400	2000/600	2500/450	6300/1500	1000	510	710	2950	4920
Axial spring stiffness (N/mm) $C_a$	50/30	90/55	80/55	150/85	150/85	280/150	85	190	280	310	510
Moment of inertia ( $10^{-3}$ Kg $m^2$ ) $J$	0,15	0,4	0,8	0,8	1,5	4	7,2	26,1	26,1	48	62
Tightening torque of the retaining screws (Nm) $M_A$	4,5	8,5	10	14	14	18	26	45	80	85	210
Weight (approx. kg) $m$	0,4	0,8	1,3	1,3	1,6	3,4	4,2	8,5	8,5	15	21
Max. approved misalignment	(mm) radial $\Delta K_r$	0,1/0,2	0,1/0,2	0,2/0,2	0,2/0,2	0,2/0,2	0,2	0,2	0,2	0,2	0,2
	(mm) axial $\Delta K_a$	0,4/0,5	0,4/0,5	0,4/0,5	0,4/0,5	0,4/0,5	1,0	1,0	1,0	1,0	1,0
	(degree) angular $\Delta K_w$	1,0/1,5	1,0/1,5	1,0/1,5	1,0/1,5	1,0/1,5	1,5	1,5	1,5	1,5	1,5
Max. rotating speed at $V=30$ m/s ( $min^{-1}$ ) $n_{max}$	11000	9100	7000	7000	6700	5200	4600	3700	3700	2800	2800

## Dimensions series AK

Type	30	60	80	150	200	300	500	800	1400	3000	5000
L (mm) $\pm 2$	52/60	63/73	80/91	80/92	80/93	91/104	113	170	170	206	206
Ø A (mm) max.	56	66	82	82	90	110	122	157	157	157	208
Ø B (mm)	52	63	80	80	85	110	122	152	152	152	190
D <sub>1</sub> <sup>H7</sup> /D <sub>2</sub> <sup>H7</sup> (mm) min.	12	15	20	20	20	25	35	50	50	70	60
	(mm) max.	20	25	35	35	40	50	55	70 <sup>2)</sup>	70 <sup>2)</sup>	80 <sup>2)</sup>
F (mm)	45/53	55/65	72/83	72/84	72/85	80/93	102	150	150	190	186
G (mm)	29/37	37/47	50/61	50/62	50/63	54/67	72	110	110	150	146
H (mm)	16/24	21/31	24/36	24/36	25/37	29/40	40	84	84	84	94
I (DIN 933)	6 x M5	6 x M6	6 x M6	6 x M6	6 x M6	6 x M8	6 x M8	6 x M16	6 x M16	6 x M12	6 x M16

- 1) Keep space for the releasing screws
- 2) Larger bores on request
- 3) Stainless steel version also available

Ordering data

AK 150/80 - 30<sup>H7</sup> - 35<sup>H7</sup> - xxx

Type length

Bore diameter D<sub>1</sub>

Bore diameter D<sub>2</sub>

Further details e.g. material