



## CEM3378/3379 Voltage Controlled Signal Processors

---

The CEM3378 and CEM3379 contain general purpose audio signal processing blocks which are completely separate from each other. These devices are useful in a wide variety of audio and musical instrument applications.

The CEM3378 includes a two-channel voltage controlled mixer, a wide range four-pole low-pass voltage controlled filter with voltage controlled resonance, and a high quality voltage controlled amplifier featuring low noise and low control voltage feedthrough without trimming.

The CEM3379 includes the same filter and VCA as the CEM3378, but instead of an input mixer, provides a two-channel voltage controlled output pan function.

Since all blocks have separate input, output, and control terminals they may be interconnected as shown in the block diagrams, or used separately in different parts of a system. With the exception of the filter frequency, all control voltage inputs range from 0 to +5V and provide moderately high impedance for minimal system loading; the filter frequency control voltage ranges from -150mV to +100mV, allowing easy control voltage mixing and all parameters to be conveniently controlled with a single polarity DAC.

Able to operate over a wide supply range and requiring a bare minimum of external components, the CEM3378 and CEM3379 offer the designer means to create unique signal processing configurations at the lowest possible cost.

### FEATURES

- Low Cost
- VCF and 4 VCAs on a single 18 pin DIP
- Separate inputs and outputs for each function
- Choice of Balance (3378) or Pan (3379)
- Rich Sounding VCF
- Constant Amplitude versus Resonance VCF Design
- Low Noise, Low Distortion VCA
- Very Low Control Voltage Feedthrough without trims
- Operation down to +/-5V

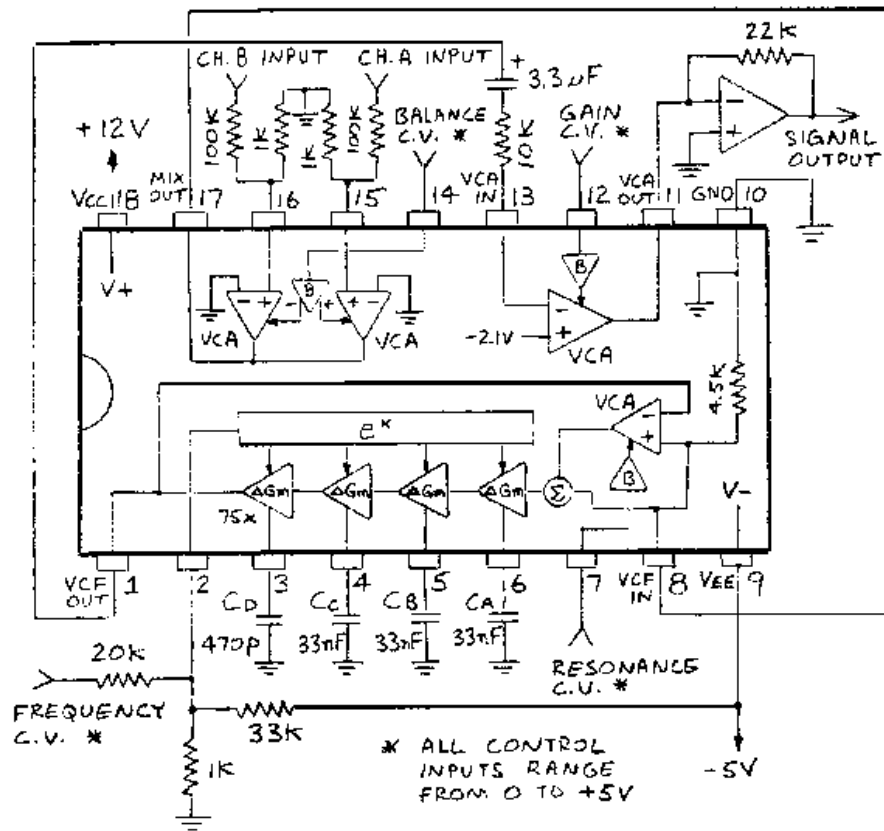

CEM3378 BLOCK & TYPICAL CONNECTION DIAGRAM

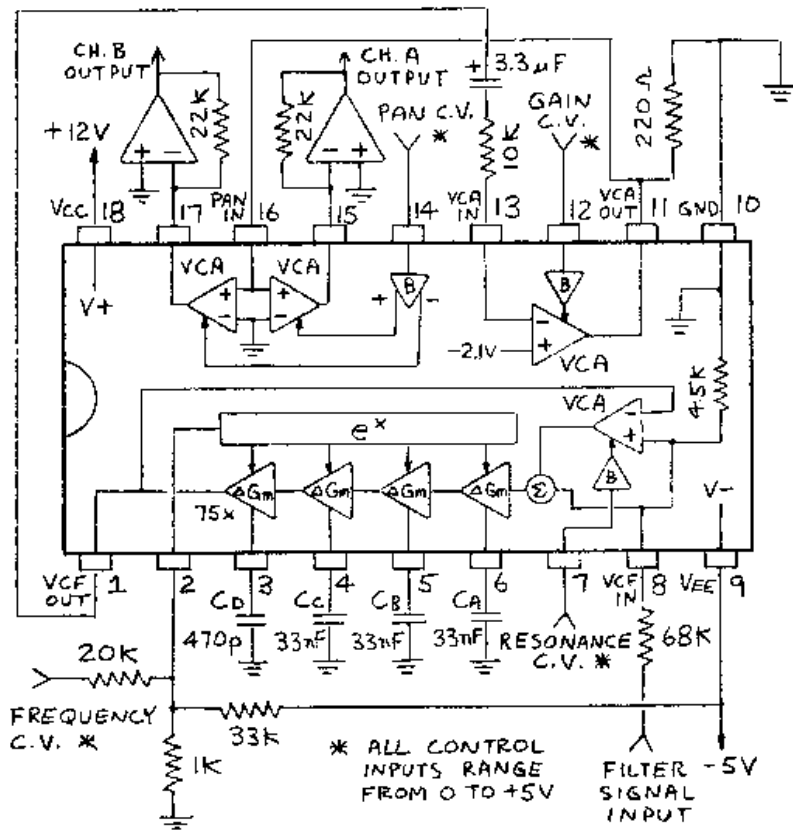

CEM3379 BLOCK & TYPICAL CONNECTION DIAGRAM

## CEM3378/79 Electrical Characteristics

PARAMETER	MINIMUM	TYPICAL	MAXIMUM	UNIT
<b>INPUT MIXER/OUTPUT VCAs</b>				
Gain range for 0-+5V control	0-3.0	0-3.8	0.4.8	mmho
Input signal for 5% THD	---	75	---	mV pp
Attenuation at VBAL=0 or VBAL=5	80	100	120	dB
DC Control voltage feedthrough	---	10	30	uA
Signal Input Bias Current	-0.2	-0.6	-2.0	uA
Balance Control Input Bias	-1.5	-5	-15	uA
Maximum Output Current	+150	+200	+260	uA
Gain Variation (part to part)	---	0.7	2.0	dB
<b>VC FILTER</b>				
Input signal for 1% THD	---	360	---	mV PP
Passband Signal Gain Vres=0V	6.8	7.5	8.3	
Input Resistance	3.6	4.5	5.6	KOhm
Frequency Control Range	14	---	---	octaves
Frequency Control Voltage	-155	---	110	mV
Frequency Control Scale	17.5	19.0	20.5	mV/octave
Exponential Scale Error	---	0.3	1.0	%
Initial Frequency (Ca-Cc=0.033uf)	650	1000	1650	Hz
Frequency Control Input Bias	-0.2	-0.6	-2.0	uA
Resonance Control Range	Q = 0dB	---	self-osc	
Resonance Control Voltage @osc	2.2	2.8	3.4	V
Resonance Control Input Bias	-0.2	-0.5	-1.5	uA/V
DC Output Shift over 10 Octaves	---	100	250	mV pp
Output noise	---	90	---	uVrms
Maximum Output Swing	4.5	5.0	5.5	Vpp
Quiescent DC Output Voltage	-0.5	0.0	0.5	V
Output Sink Current	-0.4	-0.5	-0.6	ma
Output Source Drive Current	---	---	3.0	ma
<b>FINAL VCA</b>				
Gain Control Range	90	120	---	dB
Maximum Signal Current Gain	0.80	0.93	1.10	
Control Voltage for Max Gain	4.5	5.0	5.5	V
Control Voltage for Min Gain	30	85	140	mV
Control Input Bias Current	-0.1	-0.3	-1.0	uA/V
Voltage at Signal Input Node	-2.3	-2.1	-1.9	V
Output Voltage Range	-0.8	---	Vcc-1	V
Maximum Input Signal Swing	-200	---	200	uA
Output Noise	---	---	2.0	nA rms
THD @ +/-200uA Input Swing	---	0.5	1.5	%
DC Output Offset at Min Gain	---	---	1.0	nA
DC Output Offset Range	---	+0.2	+1.2	uA
<b>GENERAL</b>				
Supply Voltage Range	+4.75	+9	+12.5	VDC

Supply Current per Chip	5.8	7.3	9.1	ma
<b>POWER SUPPLIES</b>				

The maximum supply allowed across either device is 25 volts. Due to internal voltage regulators, the supplies do not have to be balanced: +5/-12 is allowed, as would be +12/-5. Since the maximum positive output swing of the filter is 2.9 volts below the positive supply, some loss in maximum VCF output will occur at +4.75 volt supply. For best performance with low power dissipation, use +9/-5 or +12/-5 supply voltages.

#### INPUT MIXER (3378) and OUTPUT PAN (3379)

These VCAs are simple 3080 types with the inverting inputs internally connected to ground. Thus, the external input should be driven from a low impedance (<1K) referenced to ground. Control feedthrough may be trimmed if desired by applying a +5mV adjustable voltage to the input pin. Note that in the 3379, the inputs are common and so there will be a slight mismatch between sections.

The gains of the two VCAs are complementary, being equal and half of maximum at a control voltage of 2.5 volts. The control scales a linear between 1.0 and 3.5V, becoming logarithmic beyond these extremes.

Since the VCA output(s) have a limited negative output voltage compliance (-0.2V), they must be fed to a virtual ground summing node on an op amp for large output voltage swings. However, in cases where the output(s) drive another 3080-type VCA or the input of the VCF section (where the control voltage swing is less than +200mV), the output current may be converted to the required voltage simply with a resistor connected from the output pin to ground.

In the case of driving the VCF input, an external load resistor is not required since there is an internal 4.5K (nominal) resistor to ground on the VCF input pin. The VCA voltage gain from input to output is  $G_m \times R_l = 3.8 \text{ mmho} \times 4500 = 17$ . Thus, the nominal filter input of 360 mvpp is achieved with a VCA input of only 21 mvpp, allowing a typical THD of <0.1%. If more distortion can be tolerated, then a better signal-to-noise ratio can be obtained through the VCA by adding a resistor from the VCA output/VCF input to ground. A value of 1.6K for instance will lower the gain from 17 to 4.5, requiring a VCA input of 80 mvpp, or a 12dB SNR improvement.

#### FILTER

The voltage controlled filter (VCF) is the standard musical 4 pole low pass with internal feedback through a VCA to add resonance or sustained oscillation at the cut-off frequency. A portion of the input signal is applied to the resonance VCA, so that as the amount of resonance is increased, the passband gain drops by only 6dB instead of the normal 12dB without this technique. This choice of a 6dB drop ensures the peak-to-peak output level remains the same when the output waveform rings from added resonance.

If the VCF input signal comes from a source other than the mixer output, it will most likely require attenuation down to the nominal 360mv pp level. This is easily accomplished with a single series resistor to the input pin (Pin 8). The amount of attenuation is given by:

$$1 + (R_{in}/4500)$$

However, the internal 4500 ohm resistor has a 25% tolerance, so a chip-to-chip +/-2.5dB variation is to be expected. Lower variation can be obtained by adding a shunt resistor to ground. A 1.3K shunt resistor will reduce the input resistance to 1K and the output variation caused by the 4.5K will be reduced to +/-0.5dB. For best performance, the signal applied to the filter input should have < 50mv DC component.

The cut-off frequency of the filter (which is defined as the oscillation frequency at maximum resonance or the -9dB point at no resonance) is determined by the transconductance and associated capacitance of each of the 4 stages as:

$$f_c = G_m / (2 \times \pi \times C)$$

Since the transconductance of the last stage is 1/75<sup>th</sup> of the other 3 stages, the capacitor value is 1/75<sup>th</sup> of the other capacitors. Best sweep performance is obtained over a transconductance range of 1umho to 4 mmho. For a desired frequency range of 5Hz to 20KHz, Ca, Cb, and Cc are chosen to be 33nF and Cd becomes 470pF. Note that the frequency can be swept one octave above and below these frequencies.

The transconductance is varied in an exponential manner with the control voltage, and is given in umhos by

$$G_m = 200 \exp(V_{\text{freq}} / V_T)$$

where  $V_T$  is approximately 28.5mv at 20C and has a temperature coefficient of +3300ppm. Note that when  $V_{\text{freq}} = 0$ , the transconductance is nominally 200 umho, resulting in a cutoff frequency of around 1KHz with the capacitors given. The lower frequency of 5Hz is 7.6 octaves below the zero control voltage. This requires a -150mv signal. The upper limit of 20Khz requires a 90mv control voltage signal.

In the usual case, the system frequency control voltage must be attenuated with a resistor divider down to these levels. If the system CV ranges from 0 to a positive value (most likely), then an additional resistor between the control pin and the negative supply voltage is needed to produce a negative voltage for the lower cutoff frequencies. For best results, the input impedance to the control pin should be <2K. Although the transconductors themselves have been internally temperature compensated, the control scale still has a -3300ppm factor due to TC. Therefore, a +3300ppm temperature compensation resistor is used in the CV attenuation network.

The VCF output (Pin 1) is a low impedance output capable of driving loads down to 6.8K. If more drive is required, a resistor  $R_{\text{out}}$  may be connected between the output and the negative supply. The minimum load which may be driven is:

$$R_{\text{load}} (\text{Kohm}) = 2.5 / (0.4 + V_{\text{ee}} / R_{\text{out}})$$

where  $R_{\text{out}}$  is in Kohms. The output is not short circuit protected. Therefore, if this pin is connected to outside of the equipment, a series resistor of 470 ohms in series with the output pin is needed.

## FINAL VCA

The final VCA is a low noise, low control voltage feedthrough design which does not require any trimming to null. Hence it is well suited for being controlled by fast transition envelopes without producing “pops” or “clicks”.

The VCA signal input is a current summing input at a voltage of -2.1V, requiring an external series capacitor and resistor between the input signal voltage and input pin (Pin 13). The maximum input current should be limited to +-200uA. The value of input resistor is therefore:

$$R_{in} = V_{in}/400\mu A$$

The series capacitor is then chosen to give the desired -3dB low frequency corner with the selected resistor.

Somewhat lower distortion can be obtained with a lower maximum input current of +-50 to +-100uA at the expense of slightly lower signal-to-noise ratio and larger relative control feedthrough. Distortion also increases the lower input signal voltage; therefore the input signal voltage should be kept about 1Vpp.

The control scale is exponential from 0 to approx. 200mv, controlling the current gain from -100dB to about -20dB. Thereafter the current gain increases in a linear fashion until it reaches 0dB at +5V nominal. This slight rounded knee at the scale bottom allows an envelope to decay to zero with a natural exponential sound regardless of the small variations in VCA turn-on threshold.

As this VCA also has limited negative output voltage compliance (-1v max.), it is best to convert the output current to a voltage with a virtual ground summing op amp. Of course, if the output voltage needs to be no greater than 2V pp, the current-to-voltage conversion may be accomplished with a resistor to ground. The maximum voltage gain at +5V control is:

$$A_{max} = R_f/(R_{in} + 1.5K)$$

The outputs from several VCAs may be summed together by simply connecting the output pins together before converting to a voltage.