

Data sheet

# Thermo. operated water valve

## AVTA



Thermo. operated water valves are used for proportional regulation of flow quantity, depending on the setting and the sensor temperature.

The Danfoss range of thermo. operated water valves includes a series of products for both refrigeration and heating regulation.

The valves are self-acting, i.e. they operate without the supply of auxiliary energy such as electricity or compressed air.

The required temperature is maintained constant without unnecessary use of:

- cooling water in cooling systems,
- hot water or steam in heating systems.

The operating economy and efficiency are maximized.

### **AVTA SS for aggressive media.**

A valve body in stainless steel means that the valve can be used for aggressive media in such applications as the marine sector and the chemical industry.

### **Features**

- Insensitive to dirt
- Insensitive to water pressure
- Needs no power supply – self acting
- Opens on rising sensor temperature
- Differential pressure: 0 – 145 psi
- Maximum working pressure (MWP): 232 psi
- Maximum test pressure: 365 psi
- Maximum pressure on sensor: 365 psi
- Stainless steel version available
- The valves are pressure-relieved, i.e. the degree of opening is not affected by differential pressure  $\Delta p$  (pressure drop).
- The regulation range is defined for the point at which the valve begins to open.
- Cooling media temperature range: -13 – 266 °F
- Ethylene glycol as a cooling media up to 40%

**How it works**

Thermo. operated water valves consist of three main elements:

1. Setting section with knob, reference spring and setting scale.
2. Valve body with orifice, closing cone and sealing elements.
3. Hermetically sealed thermostatic element with sensor, bellows and charge.

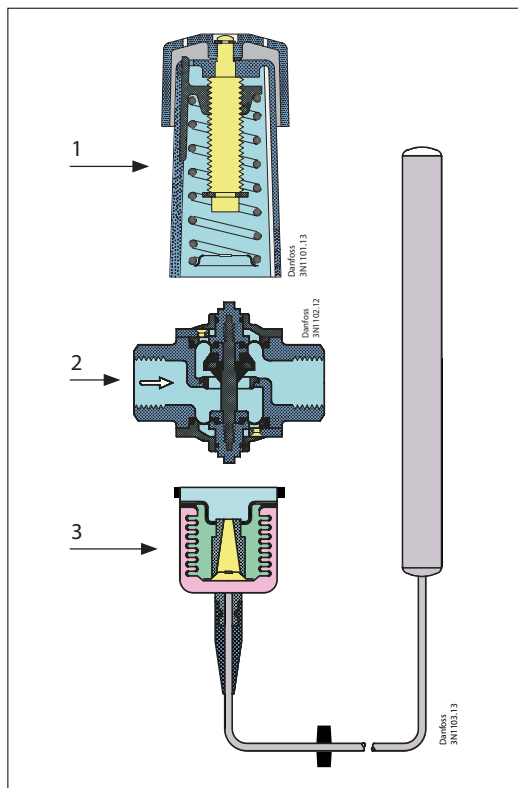

When the three elements have been assembled together, the valve installed and the sensor located at the point where the temperature is to be regulated, the function sequence is as follows:

1. The pressure changes in the sensor as a result of a change in temperature - builds up in the sensor.
2. This pressure is transferred to the valve via the capillary tube and bellows and acts as an opening or closing force.
3. The knob on the setting section and the spring exert a force that acts counter to the bellows.
4. When balance is created between the two opposing forces, the valve spindle remains in its position.
5. If the sensor temperature changes – or if the settings are changed – the point of balance becomes displaced and the valve spindle moves until balance is re-established, or the valve is fully open or closed.
6. The flow quantity change is approximately proportional to sensor temperature change.

The illustrations show an AVTA cooling water valve, but the function principle applies to all types of thermostatic valves.

**AVTA applications**



AVTA thermo. operated water valves are widely used for temperature regulation in many different machines and installations where cooling is required. AVTA cooling water valves always open to admit flow on rising sensor temperature.

The valve can be installed in either the cooling water flow line or the return line.

The standard version of the AVTA thermo. operated water valve can be used with fresh water or neutral brine.

Typical application areas:

- Injection moulding machines
- Compressors
- Vacuum pumps
- Dry cleaning machines
- Distillation plants
- Printing machines
- Hydraulic systems
- Roller mills
- Biomass boilers
- Industrial lasers
- Steam sterilizers
- Medical equipment
- Food processing

1. Oil tank
2. Hydraulic machinery
3. Heat exchangers
4. Cooling water supply
5. AVTA thermostatic valve

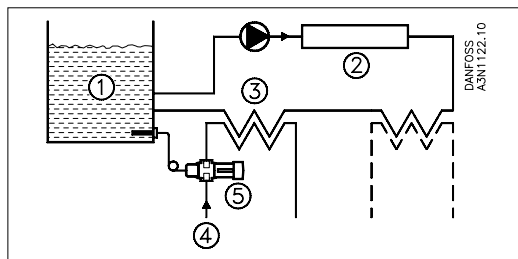

Materials

AVTA

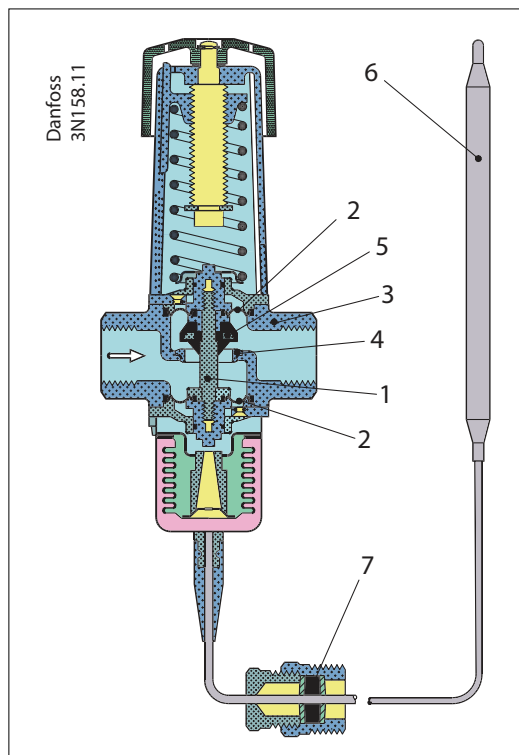

No.	Description	Material AVTA	Material AVTA SS
1	Spindle	Brass	Stainless steel
2	Diaphragms	Rubber – ethylene – propylene (EPDM).	
3	Valve body and other metal parts	Forged brass	Stainless steel
4	Valve seat	Stainless steel	
5	Valve cone	Nitrile rubber (NBR)	
6	Sensor	Copper	
7	Capillary tube gland	Nitrile rubber (NBR) / brass	

Charges

AVTA thermo. operated water valves with different types of charge



**Data sheet | Thermo. operated water valve, AVTA**

**Ordering AVTA with adsorption charge**

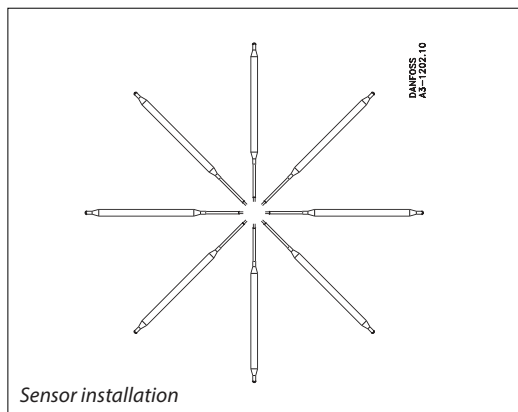

The charge consists of active carbon and CO<sub>2</sub> which is adsorbed on falling sensor temperature, thereby producing a pressure change in the element.

- Wide regulating range
- Can be installed in any position as far as orientation and temperature are concerned
- Small sensor dimensions –  $\varnothing 0.4 \times 5.9$  in
- Max. pressure on sensor 365 psi

For immersion pockets, see “Spare parts and accessories”, page 8.

Connection NPT [in]	Regulating range	Max. temp. sensor	k <sub>v</sub> value	Capillary tube length	Type	Code no. <sup>1)</sup>
	[°F]	[°F]	US [gpm]	[ft]		
½ - 14	50 – 176	266	2.2	7.6	AVTA 15	<b>003N6115</b>
¾ - 14	50 – 176	266	4.0	7.6	AVTA 20	<b>003N7120</b>
1 - 11 ½	50 – 176	266	6.4	7.6	AVTA 25	<b>003N8125</b>

<sup>1)</sup> Code no. covers complete valve incl. capillary tube gland.

**Data sheet | Thermo. operated water valve, AVTA**

**Ordering AVTA with universal charge**

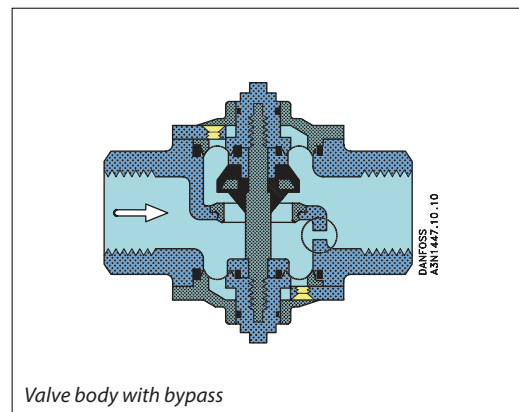
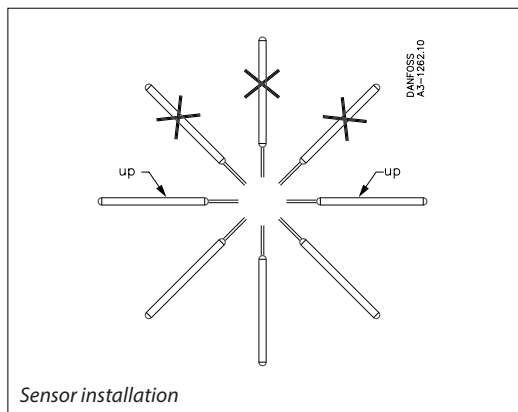

The charge is a mix of liquid and gas where the liquid surface (regulating point) is always inside the sensor. Which charge medium is used depends on the regulation range.

- Sensor dimensions  $\varnothing 0.7 \times 8.3$  in
- Sensor can be installed in a place where it is either colder or warmer than the valve
- Sensors must be orientated as shown in the sketch below
- Max. pressure on sensor 365 psi

For immersion pockets, see "Spare parts and accessories", page 8.

Connection NPT [in]	Regulating range	Max. temp. sensor	C <sub>v</sub> value	Capillary tube length	Type	Code no. <sup>1)</sup>
	[°F]	[°F]	US [gpm]	[ft]		
½ - 14	32 – 86	135	2.2	6.6	AVTA 15	<b>003N6132</b>
1 - 11 ½	32 – 86	135	6.4	6.6	AVTA 25	<b>003N8132</b>
½ - 14	77 – 149	194	2.2	6.6	AVTA 15	<b>003N6162</b>
¾ - 14	77 – 149	194	4.0	6.6	AVTA 20	<b>003N7162</b>
1 - 11 ½	77 – 149	194	6.4	6.6	AVTA 25	<b>003N8162</b>
½ - 14	122 – 194	257	2.2	6.6	AVTA 15	<b>003N6182</b>
¾ - 14	122 – 194	257	4.0	6.6	AVTA 20	<b>003N7182</b>
1 - 11 ½	122 – 194	257	6.4	6.6	AVTA 25	<b>003N8182</b>

<sup>1)</sup> Code no. covers complete valve incl. capillary tube gland.

Ordering AVTA with mass charge

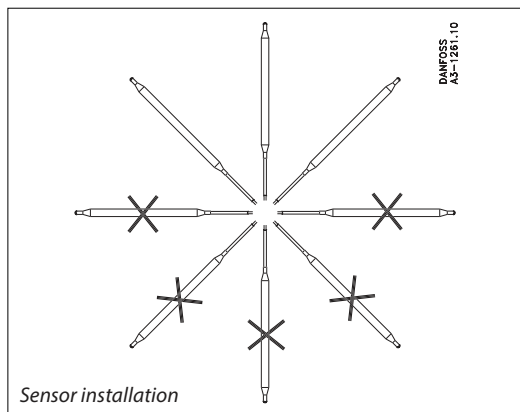

The charge is a mix of liquid and gas. Due to the mixture of liquid and gas the sensor must be installed in an area or environment that is warmer than the valve.

- Small sensor dimensions –  $\varnothing 0.4 \times 7.5$  in
- Short time constant
- Max. pressure on sensor 365 psi
- Only codes with G thread available

Connection <sup>1)</sup>	Regulating range	Max. temp. sensor	C <sub>v</sub> value	Capillary tube length	Type	Code no. <sup>1)</sup>
	[°F]	[°F]	US [gpm]	[ft]		
G 1/2	32 – 86	135	2.2	6.6	AVTA 15	<b>003N0042</b>
G 3/4	32 – 86	135	4.0	6.6	AVTA 20	<b>003N0043</b>
G 1/2	32 – 86	135	6.4	6.6	AVTA 15	<b>003N0045</b>
G 1/2	77 – 149	194	2.2	6.6	AVTA 15	<b>003N0034</b>
G 3/4	77 – 149	194	4.0	6.6	AVTA 20	<b>003N0046</b>
G 1	77 – 149	194	6.4	6.6	AVTA 25	<b>003N0047</b>

<sup>1)</sup> Code no. covers complete valve incl. capillary tube gland.

**Data sheet | Thermo. operated water valve, AVTA**

**Ordering AVTA in Stainless Steel with adsorption charge**

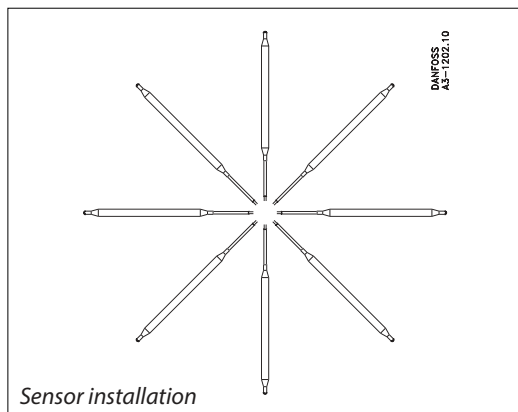

- Wide regulating range
- Can be installed in any position as far as orientation and temperature are concerned
- Small sensor dimensions –  $\varnothing 0.4 \times 5.9$  in
- Max. pressure on sensor 365 psi
- AVTA SS mass and universal charges available on request
- Only codes with G thread available.

For immersion pockets, see “Spare parts and accessories”, page 8.

Connection <sup>1)</sup>	Regulating range	Max. temp. sensor	C <sub>v</sub> value	Capillary tube length	Type	Code no. <sup>1)</sup>
	[°F]	[°F]	US [gpm]	[ft]		
G 1/2	50 – 176	266	2.2	7.6	AVTA 15	<b>003N2150</b>
G 3/4	50 – 176	266	4.0	7.6	AVTA 20	<b>003N3150</b>
G 1	50 – 176	266	6.4	7.6	AVTA 25	<b>003N4150</b>

<sup>1)</sup> Code no. covers complete valve incl. capillary tube gland.

## Data sheet | Thermo. operated water valve, AVTA

### Accessories

	Designation	Description	Code no.
		Brass for $\varnothing 0.7$ in, sensor $\frac{3}{4}$ – 14 NPT	<b>003N0051</b>
		18/8 steel <sup>1)</sup> for $\varnothing 0.7$ sensor, $\frac{3}{4}$ – 14 NPT	<b>003N0053</b>
	Immersion sensor max. pressure 725 psi L = 7.2 in	Brass for $\varnothing 0.4$ sensor G $\frac{1}{2}$	<b>017-436766</b>
		18/8 steel <sup>1)</sup> for $\varnothing 0.4$ sensor R $\frac{1}{2}$	<b>003N0196</b>
	Mounting bracket	For AVTA	<b>003N0388</b>
	Heat-conductive compound	0.01 lbs tube	<b>041E0110</b>
		1.75 lbs	<b>041E0111</b>
	Set of 3 nitrile (NBR) diaphragms sets for mineral oil	For AVTA 10/15, 20, 25	<b>003N0448</b>
		$\frac{1}{2}$ – 14 NPT	<b>003N0157</b>
		$\frac{3}{4}$ – 14 NPT	<b>003N0056</b>
	Plastic hand knob	For AVTA	<b>003N0520</b>

<sup>1)</sup>W. no. 1.4301.

### Spare parts

#### Thermostatic elements for AVTA valves

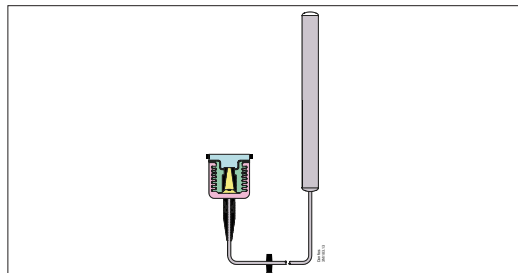

Thermostatic Elements	Temperature range	Capillary tube length	Code no.
	[°F]	[ft]	
Adsorption charge – sensor $\varnothing 0.4 \times 5.9$ in	50 – 176	7' 6"	<b>003N0278</b>
Universal charge – sensor $\varnothing 0.7 \times 8.3$ in	32 – 86	6' 6"	<b>003N0075</b>
	32 – 86	16' 5"	<b>003N0077</b>
	77 – 149	6' 6"	<b>003N0078</b>
	77 – 149	16' 5"	<b>003N0080</b>
	122 – 194	6' 6"	<b>003N0062</b>
Mass charge – sensor $\varnothing 0.4 \times 7.5$ in	77 – 149	6' 6"	<b>003N0091</b>
	77 – 149	16' 5"	<b>003N0068</b>

**Installation**

AVTA with mounting bracket

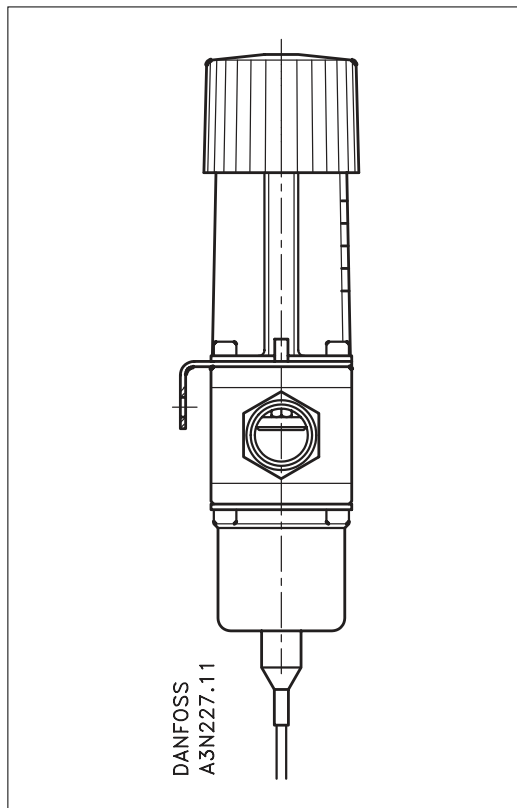

The valves can be installed in any position. An arrow on the valve body indicates the direction of flow.

AVTA valves are marked so that the letters RA are the right way up when the valve is held as shown. The installation of an FV filter ahead of the valve is recommended.

**Capillary tube**

Install the capillary tube without sharp bends (no "kinks"). Make sure that there is no strain on the capillary tube at the ends. Relief is important where vibration might occur.

**Note:**

When an AVTA valve is used, the sensor must be able to react to variations in cooling water temperature on system start. Therefore a bypass line with a shut-off valve might be necessary to ensure flow at the sensor during start-up. If a mounting bracket is used – see "Spare parts and accessories", page 10 – it must always be positioned between the valve body and the setting section (see illustration).

**Sizing**

When sizing and selecting thermo. operated water valves, it is most important to ensure that the valve is able to give the necessary quantity of cooling water at any time, irrespective of the load. Therefore, to select a suitable size of valve it is necessary to know the precise amount of cooling required. On the other hand, to avoid the risk of unstable regulation (hunting), the valve should not be oversized.

The type of charge must be selected on the basis of the temperature to be maintained, and on an assessment of the characteristics of each type, as described in the foregoing.

In general the aim should be to select the smallest valve capable of giving the required flow.

It is also recommended that the temperature range be chosen so that the required sensor temperature lies in the middle of the regulation range.

To help fine-setting the valve, a thermometer should be installed near the sensor.

*Example*

A cooling water valve must be selected for the temperature regulation of a vacuum pump.

Since direct regulation of the oil temperature is required, an AVTA valve is suitable.

The sensor position is horizontal – and small dimensions are desired.

*Given data:*

- Necessary cooling at full load 5 TR.
- Oil temperature to be maintained constant at 113 °F
- Cooling water  $p_1 = 60$  psi
- Outlet  $p_3 = 0$  psi
- $p_2 = \frac{p_1 + p_3}{2}$  (guess)
- Cooling water temperature  $t_1 = 88$  °F
- Outlet temperature  $t_2 = 68$  °F

1. Using the graph in fig.1, you find the necessary cooling water quantity at  $\Delta t = 20$  °F (88 – 68 °F) for 6 US [gpm].
2. Using the graph in fig. 2, you find the necessary  $C_v$ -value for 6 US [gpm] at  $\Delta p = 30$  psi  $(60 - 0)/2$  for 1.17 US [gpm].
3. It can be seen from the columns in fig.2 that all three AVTA valves can be used, but the preferable selection is a valve where the necessary  $C_v$ -value lies in the middle of the range. So in practice an AVTA 15 ought to be selected as it fully meets the demand.

*Valve size*

The following data are used when selecting the valve size:

- Required cooling water flow, Q [US [gpm]]
- Temperature rise in cooling water,  $\Delta t$  [°F]
- Differential pressure across valve,  $\Delta p$  [psi].

With fully open valve, the differential pressure should be around 50% of the total pressure drop across the cooling system.

The charts on page 12 are intended to make valve sizing easier.

Fig. 1 – Relation between heat quantity [kW] and cooling water quantity

Fig. 2 – Graphs of  $C_v$  values

Fig. 3 – Valve operating range

Fig. 4 – Flow quantities as a function of pressure drop  $\Delta p$

Operating conditions and other product requirements in this example mean that a valve with adsorption charge is the correct choice.

The temperature range 50 – 176 °F is in order.

The table on page 4 gives AVTA 15, code no. **003N6115**, which fulfill the requirements. To facilitate the installation a sensor pocket is often used. A sensor pocket for  $\varnothing 0,4$ " sensor in brass, code no. **017-436766**, or in stainless steel, code no. **003N0196**, is listed under "Accessories" on page 10.

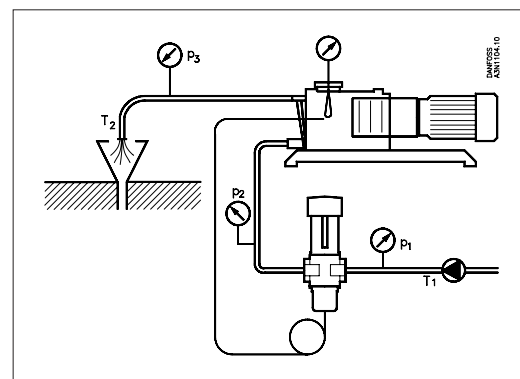

**Sizing**  
(continued)

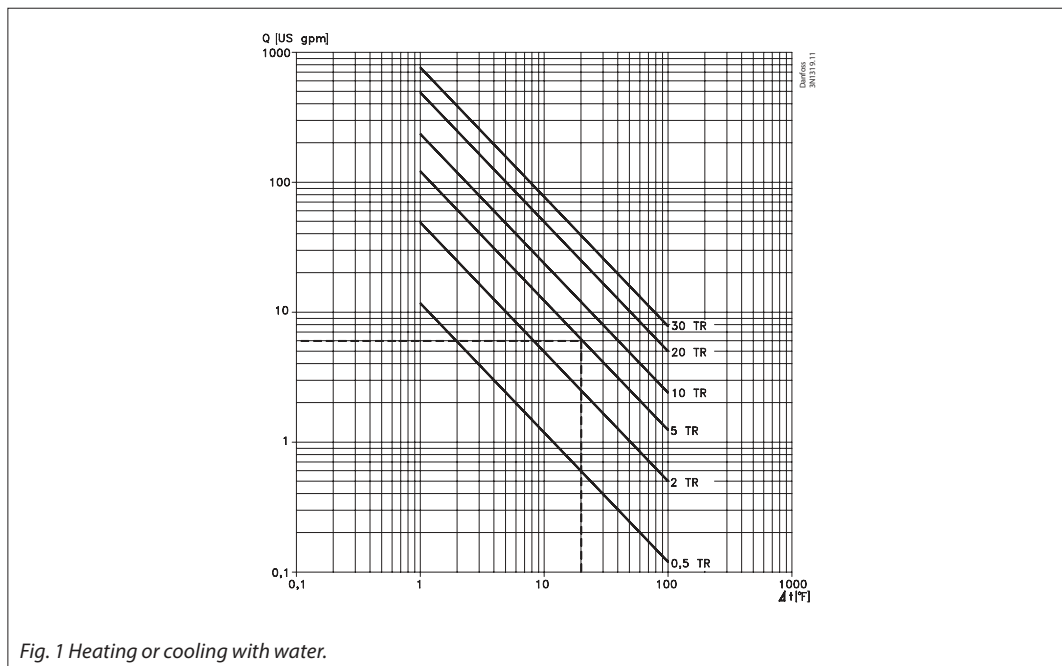

Fig. 1 Heating or cooling with water.

**Example:**  
Necessary cooling output 5 TR with  $t = 20\text{ }^\circ\text{F}$ .  
Required flow is 6 US [gpm].

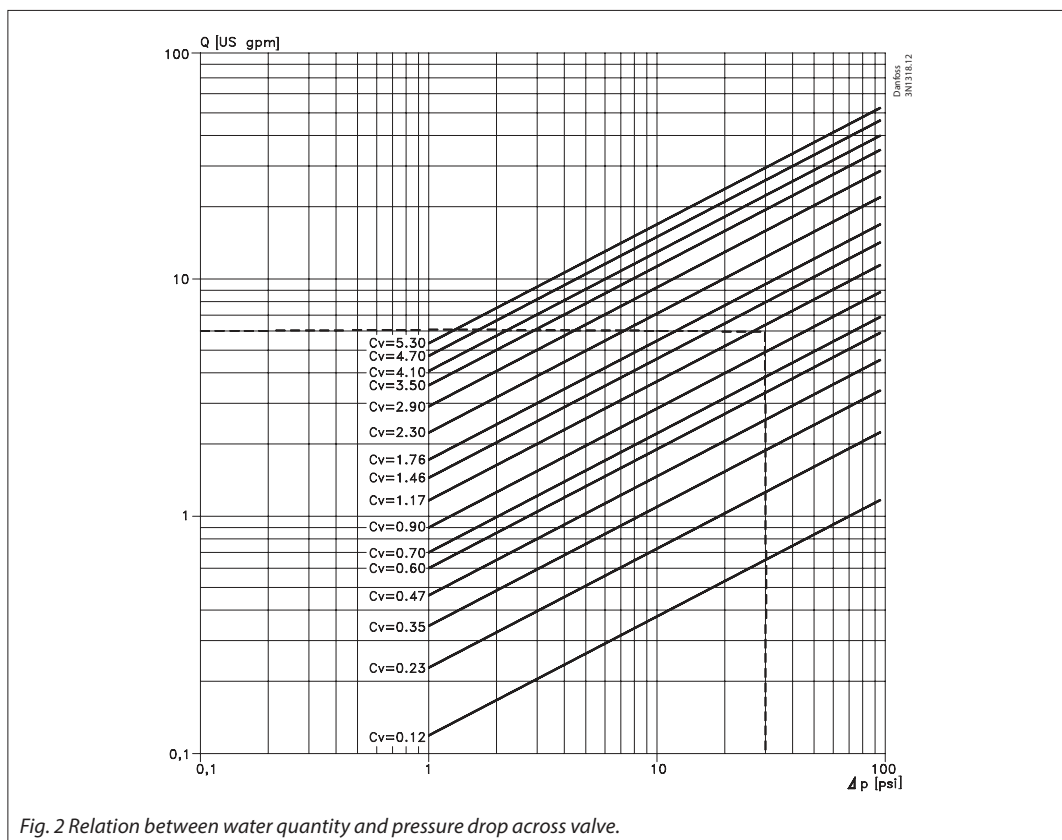
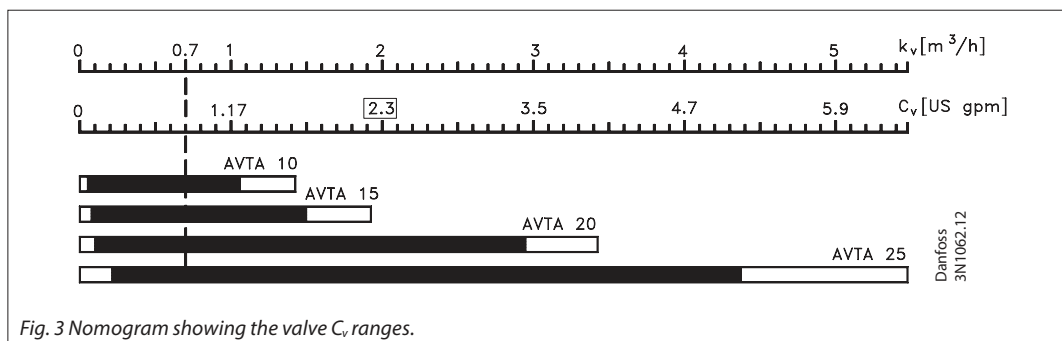

Fig. 2 Relation between water quantity and pressure drop across valve.

**Example:**  
Flow 6 US gpm with a pressure drop of 30 psi.  
The  $C_v$  value becomes 1.17 US [gpm].

**Data sheet | Thermo. operated water valve, AVTA**

**Sizing**  
(continued)



$C_v$  values are always water flow in US gpm for a pressure drop  $\Delta p$  of 1 psi. The preferable selection is a valve where the necessary  $C_v$ -value lies in the middle of the range, as a valve with a  $C_v$ -value close to either the max. or min. value is less stable and less precise due to either a relatively large  $\Delta p$  or  $\Delta Q$ .

**Example:**  
AVTA 10 and 15 are the most suitable for a  $C_v$  value of 1.17 US [gpm].

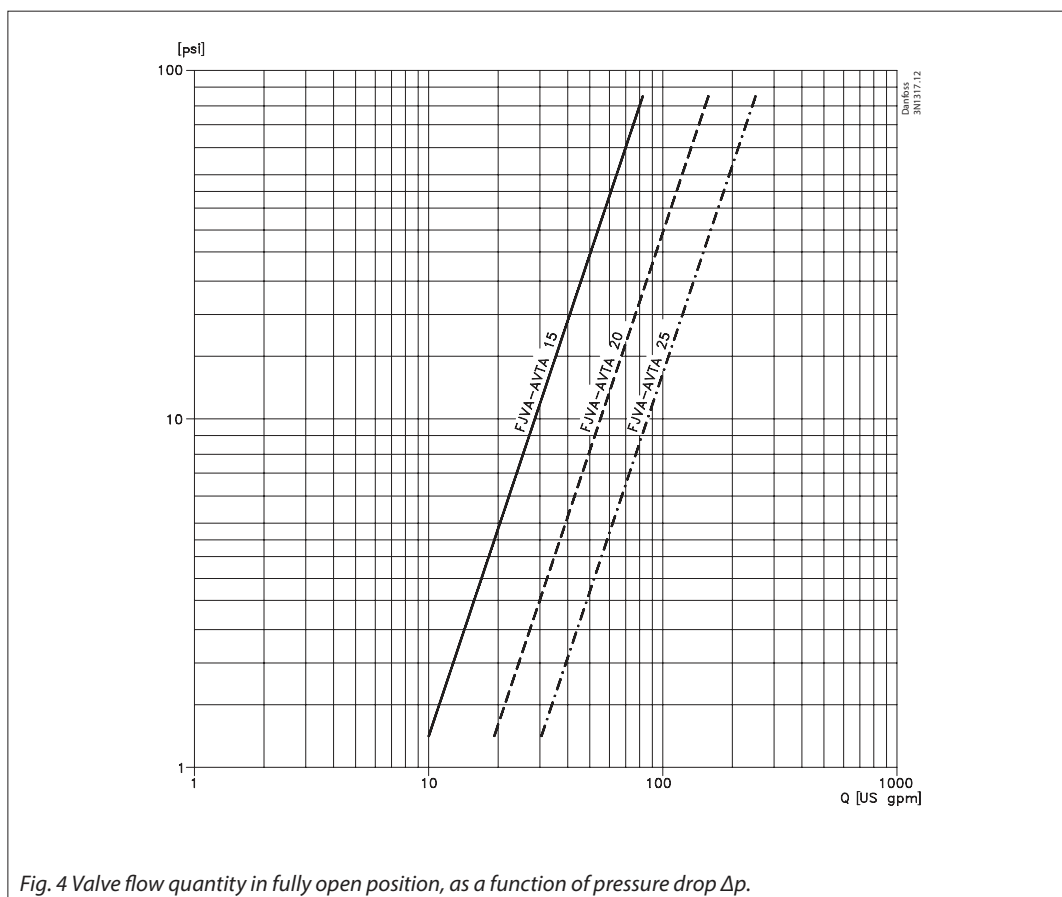

**Options**

- DZR brass
- Outer thread connecting
- Other lengths of capillary tubes
- Armouring of capillary tubes
- Other combinations of sizes, materials and ranges
- NPT – connection, see separate datasheet for USA / Canada

**Dimensions [in] and weights [lbs] of AVTA valves in brass and stainless steel housings**

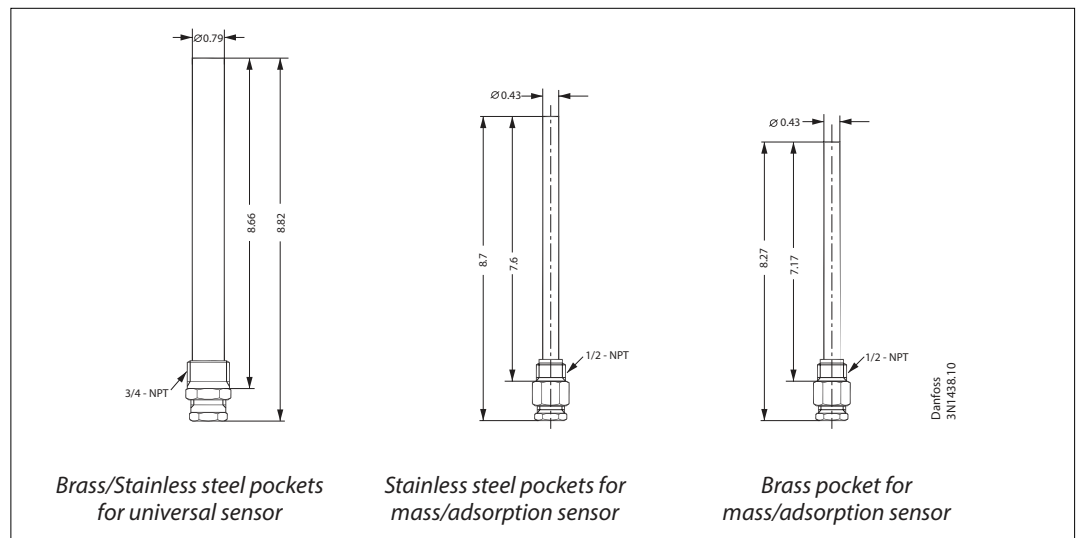
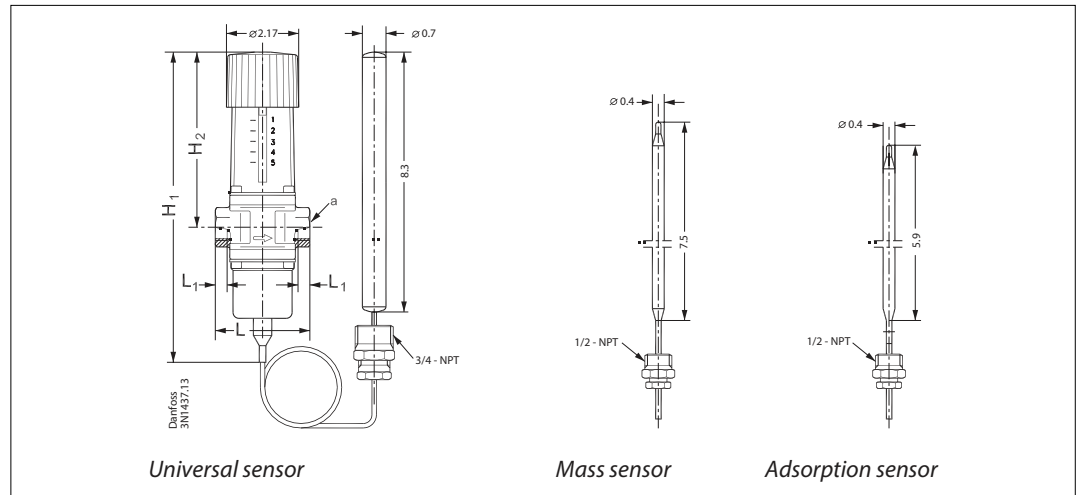

Type	H <sub>1</sub>	H <sub>2</sub>	L	L <sub>1</sub>	a	Net weight
AVTA 15	9.45	5.24	2.84	0.56	G 1/2	3.20
AVTA 20	9.45	5.24	3.55	0.63	G 3/4	3.31
AVTA 25	9.85	5.43	3.74	0.75	G 1	3.64