

New sensor DF-K for UNIVERSAL series Power Clamps and Locating Pin Units

Series:	Power Clamps Locating Pin Units
Product description:	UNIVERSAL series Power Clamps and Locating Pin Units
Modification description:	Power Clamps and Pin Locating Units belonging to the a.m. series are standard equipped with DF-K sensor instead of DF-U sensor, guaranteeing fully interchangeability
Modification reason:	Product optimization and update
Effective date:	UNIVERSAL units with DF-K sensor immediately replace the same equipped with DF-U sensor. DF-U sensors are still available as spare parts.

DISCONTINUED UNIVERSAL Series with DF-U sensor



DF-U Sensor

UPGRADE UNIVERSAL Series with DF-K sensor

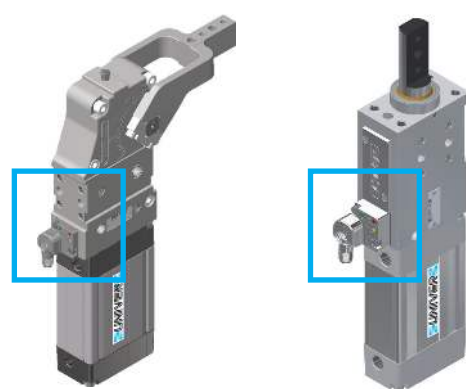

DF-K Sensor



DF-U

- Metal body IP67
- Optical/Mechanical
- Orientable connector M12

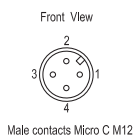

DF-K

UPGRADE

- Metal body IP67
- Fully optical
- Orientable connector M12

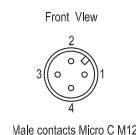

For any further information do not hesitate to contact our Sales Department.

DF-K

Electronic sensor



TECHNICAL CHARACTERISTICS

Supply tension	10-30 V DC
Supply current	<25 mA
Rated operational current	30 mA
Tension failure	<3,5 V DC
Output logic	PNP N.O.
Led-supply	green (power)
Led-closed position	red (close)
Led-open position	yellow (open)
Protection class	IP 67
Weight	64 gr
No reset	

Dimensions

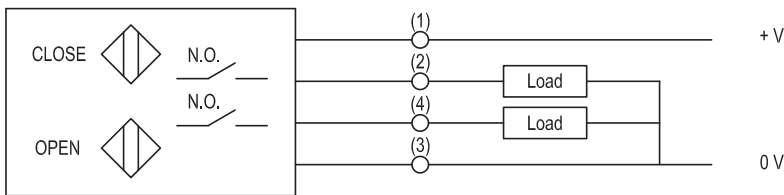
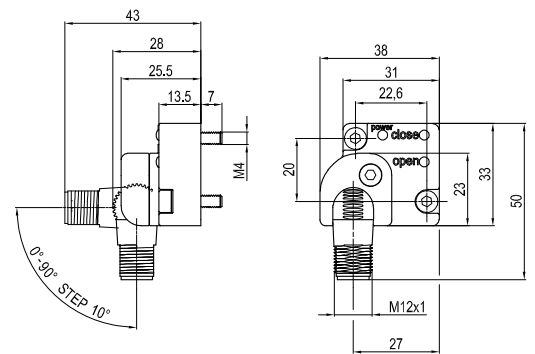

Front View

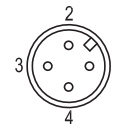

Male contacts Micro C M12

How to replace the sensor

Unscrew the 2 screws and replace the sensor.

Orientation of the connector

- Unscrew the connector screw and turn the connector to the desired position (0°÷90° in steps of 10°)
- Tighten the screw



0°



90°