

SA SELECTORIZED SERIES

SA045 - HIP THRUSTER



PRODUCT OVERVIEW

The SA045 is a selectorized strength training machine specifically designed for glute development. It features a high-smoothness pulley system to ensure fluid, stable motion and precise control throughout each repetition. With 4 levels of arm angle adjustment, 5 horizontal pad positions, and 2 angle settings for the crossbar, its 3D adjustment system allows users of all body types to find their optimal setup for efficient and focused muscle activation.

The movement path is carefully engineered based on biomechanics to closely replicate the natural hip thrust trajectory, aligning with the hip joint's anatomical curve for smoother motion and improved training effectiveness. The wide, semi-circular back pad provides stable support while allowing comfortable upper body movement during elevation. A spacious seat gives users ample room for setup and greater variability in hip and knee angles, helping to reduce lower limb compensation and enabling more accurate glute engagement.

The large, anti-slip footplate is set at a 20-degree incline to match the ankle's range of motion. It supports a variety of foot positions, from wide to narrow stances, allowing multiple angles of hip extension for comprehensive glute activation, including the gluteus maximus and medius.

SPECIFICATIONS & KEY FEATURES

Specifications

Dimension	1683*1367*1566mm
Total Weight:	258kg
Weight Stack:	100kg
Max Weight Stack:	125kg

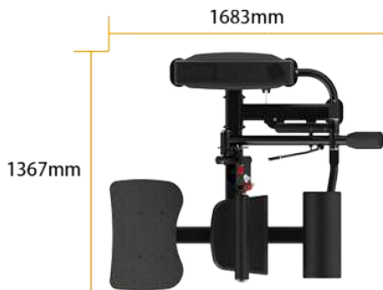
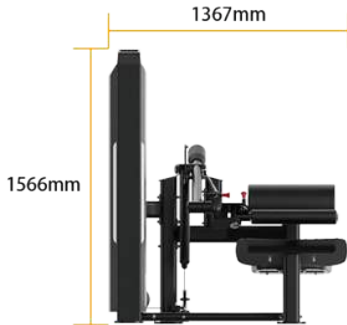
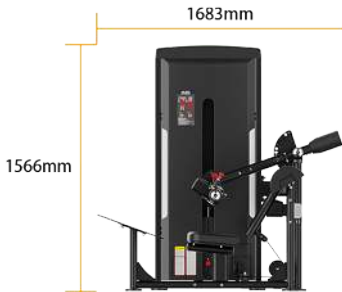

Product Features

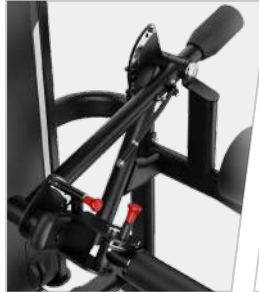

3D Adjustable Arm and Crossbar System

Supports multi-angle adjustments to accommodate different body types and movement preferences, helping users find the optimal power position for enhanced glute activation.



Biomechanically Optimized Movement Path

Mimics the natural hip thrust motion with a trajectory that follows the hip joint's arc, delivering smooth, comfortable action and more effective muscle engagement.



Ergonomic, Stable Support System

The semi-circular back pad ensures secure body support while allowing smooth movement. The generously sized seat creates ample setup space and helps maintain proper posture for focused glute training.



Wide, Angled Anti-Slip Footplate

The 20° inclined footplate enhances ankle comfort and supports various stances, enabling full-range stimulation of the gluteal muscles.