

# Hook Clamps

**Available in a variety of sizes and styles including Cam Handle**



**Long Arm Socket Head**



**Tapped Long Arm Socket Head**



**Tapped Long Arm Cam Handle**

Long-arm Hook Clamps available with either a plain or tapped arm. The tapped-arm version accepts a wide variety of contact bolts or spindles to increase clamping-height range (the tapped arm is also slightly longer). Mounts in a reamed hole or in a Hook-Clamp Mounting Block or Holder (order separately). Ideal in tight spaces where high clamping force is required. Available in three sizes.

The tapped-arm version is optionally available with a cam handle, to allow clamping without a separate wrench. Use with an adjustable contact bolt to utilize maximum cam travel.

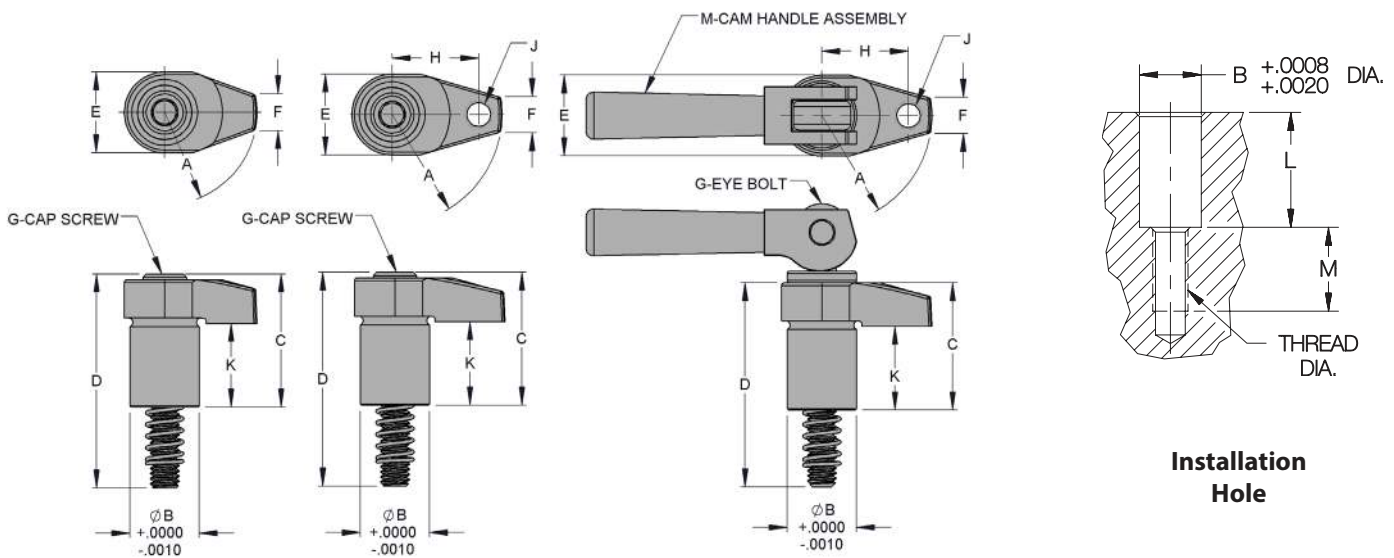

# Hook Clamps Application

Compact high force clamps that swing conveniently out of the way when in the unclamped position. An alternative to strap clamps, hook clamps require no additional room or properly adjusted rest. Available in a variety of sizes and styles, Carr Lane Manufacturing has a hook clamp to suit your unique needs.

Always made in the USA.

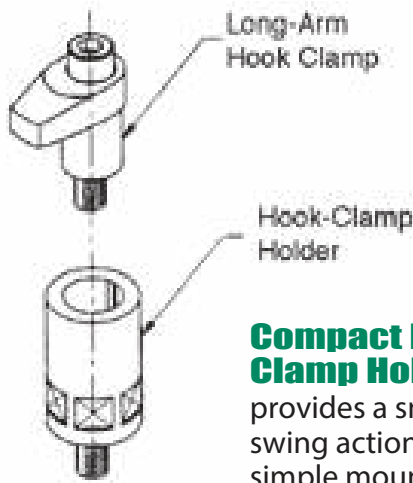

**Compact Hook Clamp Holder** provides a smooth swing action with simple mounting.

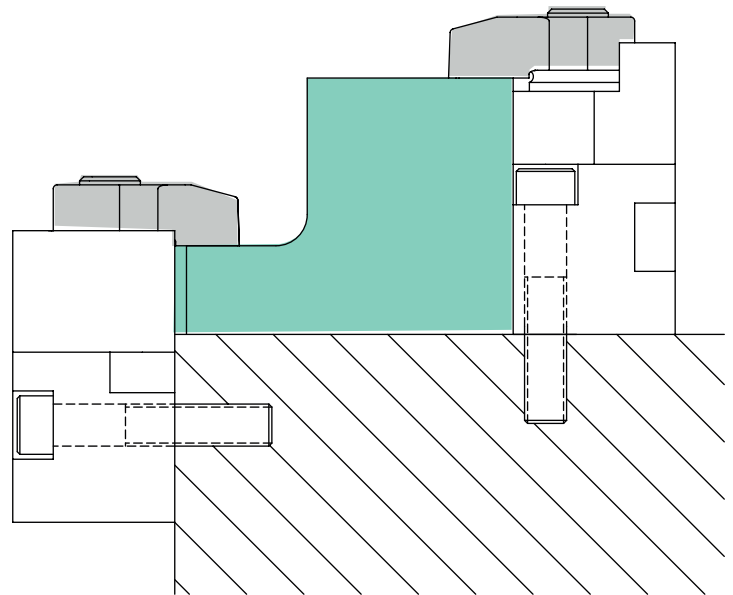

## Hook Clamp Mounting Blocks

have built-in 90 degree stops that provide consistent arm positioning. Two sets of mounting holes allow either base or side mounting.

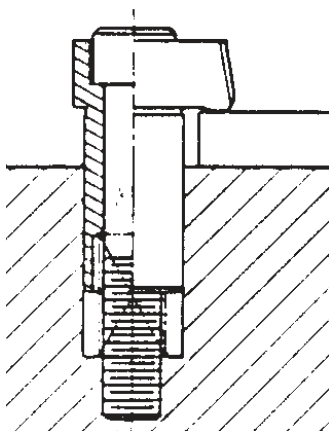

**Standard Arm Hook Clamp** excels at providing downward clamping force in applications that have limited space.

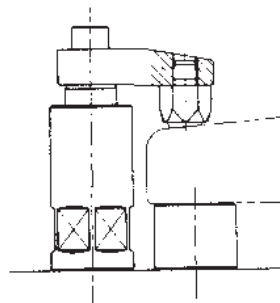

**Long-Arm Hook Clamp** available with a tapped hole allowing the use of a wide variety of contact bolts or spindles, allowing for an increased clamping range.