

INTERNATIONAL  
STANDARD

ISO  
15979

First edition  
2002-11-01

---

---

**Open end blind rivets with break pull  
mandrel and protruding head — St/St**

*Rivets aveugles à rupture de tige à corps ouvert, à tête bombée — St/St*



Reference number  
ISO 15979:2002(E)

© ISO 2002

**PDF disclaimer**

This PDF file may contain embedded typefaces. In accordance with Adobe's licensing policy, this file may be printed or viewed but shall not be edited unless the typefaces which are embedded are licensed to and installed on the computer performing the editing. In downloading this file, parties accept therein the responsibility of not infringing Adobe's licensing policy. The ISO Central Secretariat accepts no liability in this area.

Adobe is a trademark of Adobe Systems Incorporated.

Details of the software products used to create this PDF file can be found in the General Info relative to the file; the PDF-creation parameters were optimized for printing. Every care has been taken to ensure that the file is suitable for use by ISO member bodies. In the unlikely event that a problem relating to it is found, please inform the Central Secretariat at the address given below.

© ISO 2002

All rights reserved. Unless otherwise specified, no part of this publication may be reproduced or utilized in any form or by any means, electronic or mechanical, including photocopying and microfilm, without permission in writing from either ISO at the address below or ISO's member body in the country of the requester.

Printed in Switzerland

## Foreword

ISO (the International Organization for Standardization) is a worldwide federation of national standards bodies (ISO member bodies). The work of preparing International Standards is normally carried out through ISO technical committees. Each member body interested in a subject for which a technical committee has been established has the right to be represented on that committee. International organizations, governmental and non-governmental, in liaison with ISO, also take part in the work. ISO collaborates closely with the International Electrotechnical Commission (IEC) on all matters of electrotechnical standardization.

International Standards are drafted in accordance with the rules given in the ISO/IEC Directives, Part 3.

The main task of technical committees is to prepare International Standards. Draft International Standards adopted by the technical committees are circulated to the member bodies for voting. Publication as an International Standard requires approval by at least 75 % of the member bodies casting a vote.

Attention is drawn to the possibility that some of the elements of this International Standard may be the subject of patent rights. ISO shall not be held responsible for identifying any or all such patent rights.

ISO 15979 was prepared by Technical Committee ISO/TC 2, *Fasteners*.

Annex A of this International Standard is for information only.

www.irivet.ru

www.irivet.ru

www.irivet.ru

www.irivet.ru

www.irivet.ru

www.irivet.ru

1

www.irivet.ru

www.irivet.ru

www.irivet.ru

# Open end blind rivets with break pull mandrel and protruding head — St/St

## 1 Scope

This International Standard specifies dimensional and mechanical characteristics and application data for open end blind rivets with break pull mandrel and protruding head, with a steel body (St) and a steel mandrel (St) and with nominal diameters,  $d$ , from 2,4 mm up to and including 6,4 mm.

## 2 Normative references

The following normative documents contain provisions which, through reference in this text, constitute provisions of this International Standard. For dated references, subsequent amendments to, or revisions of, any of these publications do not apply. However, parties to agreements based on this International Standard are encouraged to investigate the possibility of applying the most recent editions of the normative documents indicated below. For undated references, the latest edition of the normative document referred to applies. Members of ISO and IEC maintain registers of currently valid International Standards.

ISO 3269:2000, *Fasteners — Acceptance inspection*

ISO 4042:1999, *Fasteners — Electroplated coatings*

ISO 4520:1981, *Chromate conversion coatings of electroplated zinc and cadmium coatings*

ISO 14588:2000, *Blind rivets — Terminology and definitions*

ISO 14589:2000, *Blind rivets — Mechanical testing*

## 3 Dimensions

### 3.1 General

Symbols and designations of dimensions are specified in ISO 14588.

### 3.2 Rivet dimensions

See Figure 1 and Table 1.

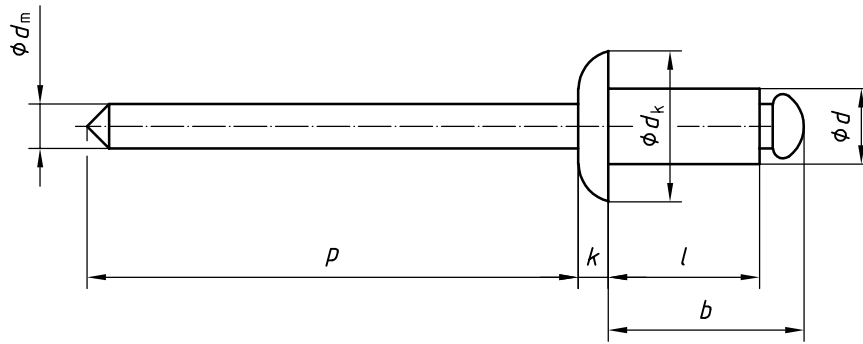

Figure 1 — Rivet dimensions

Table 1 — Rivet dimensions

Dimensions in millimetres

Rivet body	d	nom.	2,4	3	3,2	4	4,8	5	6	6,4
		max.	2,48	3,08	3,28	4,08	4,88	5,08	6,08	6,48
		min.	2,25	2,85	3,05	3,85	4,65	4,85	5,85	6,25
	d <sub>k</sub>	max.	5,0	6,3	6,7	8,4	10,1	10,5	12,6	13,4
		min.	4,2	5,4	5,8	6,9	8,3	8,7	10,8	11,6
	k	max.	1	1,3	1,3	1,7	2	2,1	2,5	2,7
Mandrel	d <sub>m</sub>	max.	1,5	2,15	2,15	2,8	3,5	3,5	3,4	4
	p	min.	25	25	25	27	27	27	27	27
Blind length	b	max.	l <sub>max</sub> + 3,5	l <sub>max</sub> + 3,5	l <sub>max</sub> + 4	l <sub>max</sub> + 4	l <sub>max</sub> + 4,5	l <sub>max</sub> + 4,5	l <sub>max</sub> + 5	l <sub>max</sub> + 5,5
Rivet length		Recommended grip ranges <sup>a</sup>								
	l <sup>b</sup>									
	nom. = min.	max.								
	6	7	0,5 to 3,5	0,5 to 3,0	1 to 3	—	—	—		
	8	9	3,5 to 5,5	3 to 5	3 to 5	2,5 to 4,0	—	—		
	10	11	—	5,0 to 6,5	5,0 to 6,5	4 to 6	3 to 4	3 to 4		
	12	13	5,5 to 9,5	6,5 to 8,0	6,5 to 9,0	6 to 8	4 to 6	4 to 6		
	16	17	—	8 to 12	9 to 12	8 to 11	6 to 10	6 to 9		
	20	21	—	12 to 16	12 to 16	11 to 15	10 to 14	9 to 13		
	25	26	—	—	—	15,0 to 19,5	14 to 19	13 to 19		
	30	31	—	—	16 to 25	19,5 to 25,0	19 to 24	19 to 24		

NOTE The rivet body dimensions are generated from the design formulae specified in annex A.

<sup>a</sup> The grip ranges of rivets with dimensions as given in Table 1, with the material combination as given in clause 4, are specified by the minimum and maximum grip lengths. The minimum grip lengths are given as a recommendation only. It may be possible to go into individual cases below the minimum values.

<sup>b</sup> Nominal lengths greater than 30 mm shall be specified in 5 mm increments. For availability and grip range refer to manufacturer.

### 3.3 Clearance hole diameters

The diameters of the clearance holes,  $d_{h1}$ , to accommodate the rivet in the components to be fastened are given in Table 2.

**Table 2 — Clearance hole diameters**

Dimensions in millimetres

$d$ nom.	$d_{h1}$	
	min.	max.
2,4	2,5	2,6
3	3,1	3,2
3,2	3,3	3,4
4	4,1	4,2
4,8	4,9	5,0
5	5,1	5,2
6	6,1	6,2
6,4	6,5	6,6

Non-conformance to the values listed in Table 2 may result in assembly difficulties and/or reduction in the shear and tensile loads specified in Table 3.

When necessary, to facilitate alignment, only the component on the access side may have a clearance hole larger than specified in Table 2 (see Figure 2). This may also result in a reduction of the shear and tensile loads specified in Table 3.

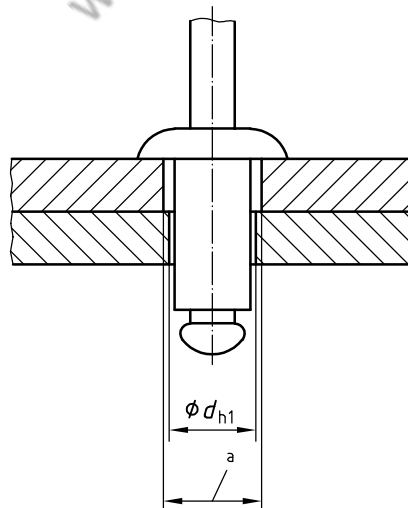

<sup>a</sup> Enlarged clearance hole

**Figure 2 — Enlarged clearance hole to facilitate alignment**

## 4 Material and finish

Blind rivets in accordance with this International Standard shall have a rivet body made of steel (St) and a mandrel made of steel (St) and shall have mechanical properties as specified in clause 5.

Material specification is at the discretion of the manufacturer.

The surface finish of rivet body shall be zinc plated 5 µm minimum in accordance with ISO 4042. The chromate conversion coating shall be c2C in accordance with ISO 4520:1981. The complete finish designation is then Fe/Zn5c2C. The thickness shall be measured on the head.

The surface finish of the mandrel is at the discretion of the manufacturer and may be oil, phosphate and oil or zinc coating.

## 5 Mechanical properties

The minimum shear load, minimum tensile load and maximum mandrel break load shall be as specified in Table 3 when tested in accordance with ISO 14589.

**Table 3 — Mechanical properties**

<i>d</i> nom. mm	Shear load min. N	Tensile load min. N	Mandrel break load max. N
2,4	650	700	2 000
3	950	1 100	3 200
3,2	1 100	1 200	4 000
4	1 700	2 200	5 800
4,8	2 900	3 100	7 500
5	3 100	4 000	8 000
6	4 300	4 800	12 500
6,4	4 900	5 700	13 000

## 6 Mandrel push-out resistance

To load to push out the mandrel shall exceed 10 N when tested in accordance with ISO 14589.

## 7 Mandrel head retention capability

The portion of the mandrel remaining in the set rivet shall not be ejected by the application of the head retention test load specified in Table 4 when tested in accordance with ISO 14589.

Table 4 — Mandrel head retention test loads

<i>d</i> nom. mm	Head retention test load
	N
2,4	30
3	35
3,2	35
4	40
4,8	45
5	45
6	50
6,4	50

## 8 Workmanship

Rivets shall be free from burrs and harmful defects and shall have well-formed heads and shanks.

After setting, rivets shall not show evidence of cracking when viewed at 5 × magnification.

## 9 Acceptance testing

If there is no other agreement, acceptance inspection in accordance with ISO 3269 applies.

## 10 Designation

**EXAMPLE** An open end blind rivet, with break pull mandrel and protruding head, with nominal diameter  $d = 4$  mm and nominal length  $l = 12$  mm with a steel body (St) and a steel mandrel (St) is designated as follows:

**Blind rivet ISO 15979 - 4 × 12 - St/St**

## Annex A (informative)

### Design formulae

#### A.1 General

Blind rivets in accordance with this International Standard comply with the following design formulae and tolerances:

#### A.2 Shank diameter

The maximum shank diameter complies with the formula:

$$d_{\max} = d_{\text{nom}} + 0,08 \text{ mm}$$

The minimum shank diameter complies with the formula:

$$d_{\min} = d_{\text{nom}} - 0,15 \text{ mm}$$

#### A.3 Head diameter

The maximum head diameter complies with the formula:

$$d_{\text{k max}} = 2,1 d_{\text{nom}}$$

rounded to one decimal place.

#### A.4 Head diameter tolerance

The head diameter tolerance is h16 for  $d_{\text{nom}} \leq 3,2 \text{ mm}$  and h17 for  $d_{\text{nom}} > 3,2 \text{ mm}$ .

#### A.5 Head height

The maximum head height complies with the formula:

$$k_{\max} = 0,415 d_{\text{nom}}$$

rounded to one decimal place.

#### A.6 Clearance hole diameter

The clearance hole diameter for blind rivet application complies with the formulae:

$$d_{\text{h1 max}} = d_{\text{nom}} + 0,2 \text{ mm}$$

$$d_{\text{h1 min}} = d_{\text{nom}} + 0,1 \text{ mm}$$

www.irivet.ru

www.irivet.ru

www.irivet.ru

www.irivet.ru

www.irivet.ru

www.irivet.ru

ISO 15979:2002(E)

---

---

**ICS 21.060.40**

Price based on 6 pages

© ISO 2002 – All rights reserved

Copyright International Organization for Standardization  
Provided by IHS under license with ISO  
No reproduction or networking permitted without license from IHS

Not for Resale