

# Conveyor system XH

## Contents

Catenary drive units XH .....	233	
Bend drive unit XH .....	234	X45
Idler units XH .....	234	
Bridges .....	235	XS
Wheel bends XH .....	236	
Wheel cover for Wheel bend .....	237	X65
Plain bends XH .....	237	
Support rail for plain bends XH .....	238	
Vertical bends XH .....	239	X65P
Angle plates XH .....	240	
Front piece XH .....	241	X85
Drip trays XH .....	242	
Drip catchers XH .....	243	X85P
Drip pans XH .....	243	

## System information



### Chain width 103 mm



### Features

Suitable for larger items, especially if point of balance is somewhat offcenter. Higher capacity than XS and X65.

### Examples of application areas

Large ball bearings, electric motors, steering arm components, secondary packages, cartons.

### Technical characteristics

Drive unit capacity .....	1250 N
Chain tension limit .....	1250 N
Beam width .....	105 mm
Chain width .....	103 mm
Chain pitch .....	35,5 mm
Item width .....	25–300 mm
Maximum item weight	
Horizontal transport .....	20 kg
Vertical transport .....	15 kg
Maximum weight on conveyor .....	150–300 kg
Maximum conveyor length .....	30 m
Maximum permitted load per link	2,0 kg

PO

CC

X45

XS

X65

X65P

X85

X85P

XH

XK

XKP

X180

X300

GR

CS

XT

HU

WL

WK

XC

XF

XD

ELV

CTL

FST

TR

APX

IDX

# Conveyor modules

## Straight conveyor

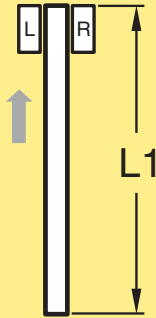

Conveyor module – straight \* **5990226**

*\*Use online configurator when ordering*

## One bend conveyor

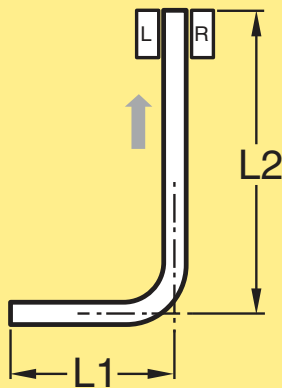

Conveyor module – one bend \* **5990230**

*\*Use online configurator when ordering*



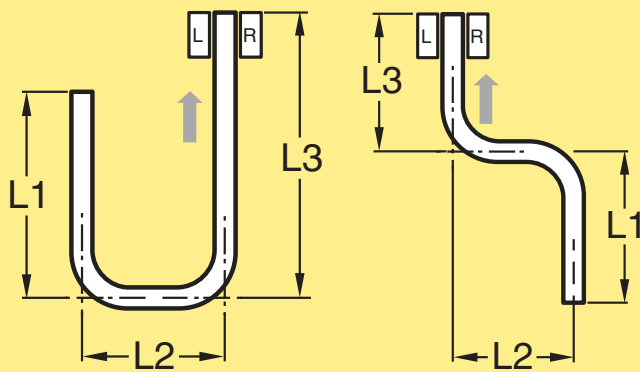







## Two bend conveyor



Conveyor module – two bends \* **5990237**

*\*Use online configurator when ordering*

## Support modules – single and multi-lane

	5995387	Single diecast
	5995388	Single end adjustable
	5995389	Single end guide roller
	5995390	Single foot plate
	5995391	Single two/three-point
	5995393	Multi single 2 lane
	5995394	Multi single 3 lane
	5995395	Multi single 4 lane
	5995396	Multi double 2 lane
	5995397	Multi double 3 lane
	5995398	Multi double 4 lane

**Plain chain**

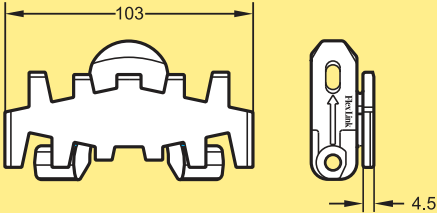

Plain chain  
Length 5 m **XHTP 5**

Plain link kit \* **5056312**

Plain chain (Ultra low wear)  
Length 5 m **XHTP 5 C**

Plain link (Ultra low wear) **n.a.**

*\*Note. Link kit contains 10 links, 10 pivot, 10 steel pins.*

**Steel top chain**

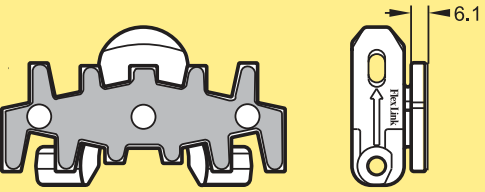

Steel top chain  
Length 5 m **XHTP 5 TF**

Steel top link kit \* **5056594**

*Note. Link kit contains 10 links, 10 pivot, 10 steel pins.*

**Friction top chain**

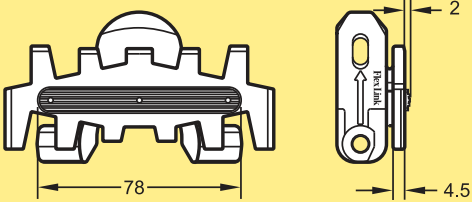

Friction top chain  
Length 5 m **XHTP 5 FP**

*Use the online configurator to specify and order.*

Friction top chain  
Length 5 m **XHTP 5 F**

Friction top link kit \* **5056593**

*\*Note. Link kit contains 10 links, 10 pivot, 10 steel pins.*

**Cleated chain, Type A**

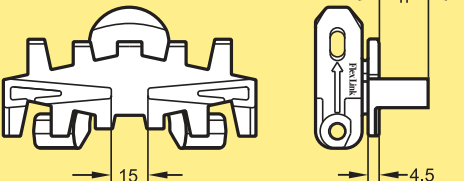

Cleated chain, Type A cleats\*  
Length 5 m  
h=15 mm **XHTF 5x15 A**  
h=20 mm **XHTF 5x20 A**  
h=30 mm **XHTF 5x30 A**  
h=40 mm **XHTF 5x40 A**

*\*Use the online configurator to specify and order.*

Cleated link kit \*\*  
h=15 mm **5056595**  
h=20 mm **5056596**  
h=30 mm **5056597**  
h=40 mm **5056598**

*\*\*Note. Link kit contains 10 links, 10 pivot, 10 steel pins.*

**Flat top friction chain**

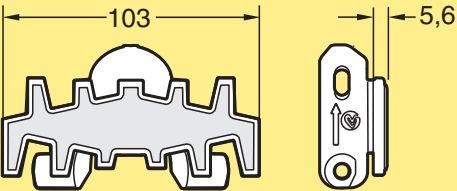

Flat top friction chain  
Length 5 m **XHTP 5 FA**

Flat top friction link kit \* **5058544**

*\*Note. Link kit contains 10 links, 10 pivot, 10 steel pins.*

**Roller top chain**

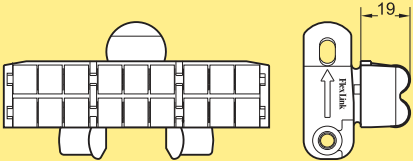

Roller top chain  
Length 5 m **XHTR 5**

Roller top link kit \*) \*\*) **5056603**

*\*Note. This link cannot be combined with plain links.  
\*\*Note. Link kit contains 10 links, 10 pivot, 10 steel pins.*

## Chain with roller cleats

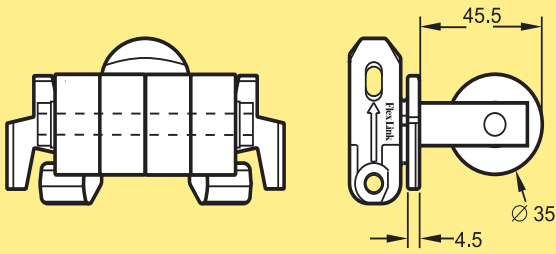

Chain with roller cleats  
Length 5 m

**XHTF 5x46 R**

Use the online configurator to specify and order.

Link kit with roller cleats\* **5056604**

Note. This type of chain requires minimum one plain link between every cleated link.

\*Note. 1 link XHTL 103x46 R with pivot and steel pin.

## Other chains

See the *Chain guide* for a selection of other chains.

## Chain installation

See Appendix C, page 527, for installation instructions

## Chain accessories XH

### Plastic pivot



Plastic pivots, kit XH (25 pcs)

**5056588**

### Steel pin

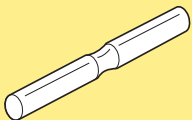

Steel pin, kit (25 pcs) XH

**5111502**

### Pin insertion tool for chain

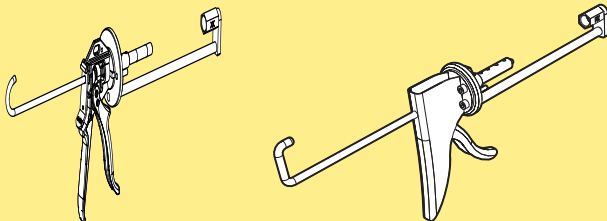

Pin insertion tool  
XH

X85-X180/X300-XH, PRO version\* **XBMJ 6 P**

This tool is recommended for frequent users

## Conveyor beam

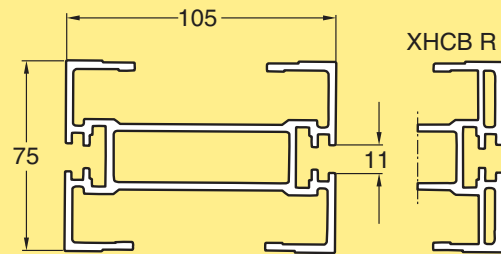

Beam

Length 3000 +10/-0 mm

**XHCB 3**

Length to order (30- 3000 mm)

**XHCB L**

Beam, reinforced

Length 3000 +10/-0 mm

**XHCB 3 R**

Length to order (30- 3000 mm)

**XHCB L R**

## Beam section for chain installation

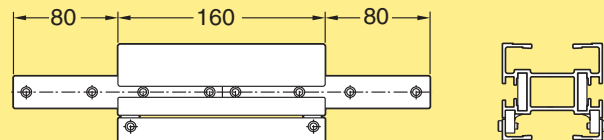

Beam section for chain installation  
Including connection strips and  
screws

**XHCC 160 A**

## Profile for split conveyor beam

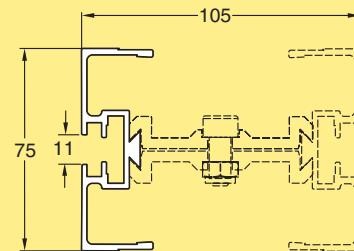

Profile for split conveyor beam

Length 3000 +10/-0 mm

**XHCB 3 H**

Length to order (30- 3000 mm)

**XHCB L H**

## Beam clip assembly

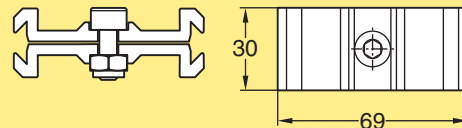

Beam clip assembly

**XHCE 69x30**

Including M8 screw and locking nut. Use minimum 5 clips per meter. Place clips 100 mm from each end.

**Connecting strip with set screws**

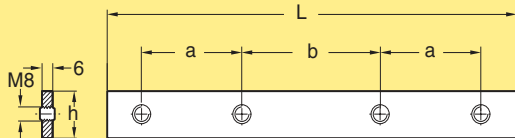

Connecting strip with set screws

h=25, a=30, b=50, L=130

h=25, a=44, b=44, L=160

**XLCJ 6x130**

**XLCJ 6x160**

Note. Contains 10 pcs.

**Cover strip for T-slot, PVC**

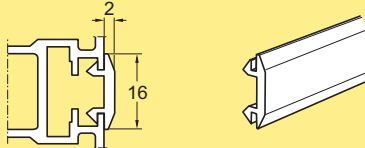

Cover strip for T-slot, PVC

Length 25 m

**XLAB 25**

For XS-XH

**Beam spacer**

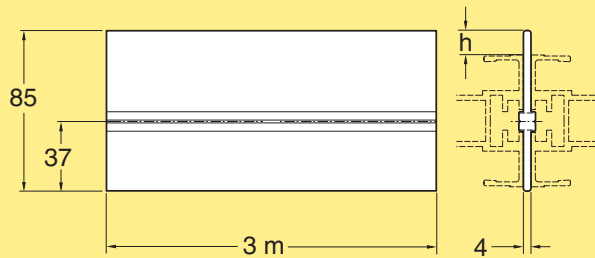

XS	X65	X85/XH	XK
h=16,0 mm	h=15,9 mm	h=10,5 mm	h=0,5 mm

Beam spacer

Aluminium, anodized

Length 3 m

**XLCD 3**

For connection of two conveyor beams side to side. Use M8 screw and slot nut. Two holes must be drilled, one through the spacer (9 mm) and one through the beam, to allow insertion of the screw. The diameter of the second hole depends on the size of the screw head.

**Articulated beam section**

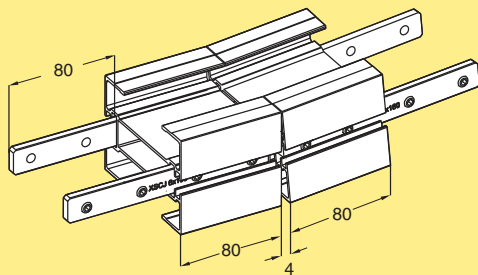

Articulated beam section vertical

**XHCH 5 V**

# Slide rails XH

## Plastic slide rails for beams

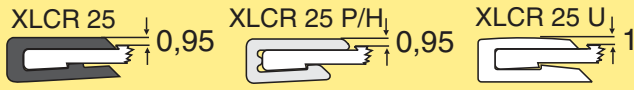

### Slide rail

Length 25 m

HDPE ( $\mu=0,1-0,25$ ) (Black)

PA-PE ( $\mu=0,1-0,25$ ) (Grey)

PVDF ( $\mu=0,15-0,35$ ) (Natural white)

PE-UHMW ( $\mu=0,1-0,25$ ) (White)

PE-UHMW conductive (Black)

**XLCR 25**

**XLCR 25 H**

**XLCR 25 P**

**XLCR 25 U**

**XLCR 25 E**

See Appendix A, page 513 for selection guidelines and assembly instructions.

## Steel slide rail for beams

XLCR 3 TA

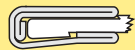

Slide rail ( $\mu=0,15-0,35$ )

Length 3 m

Acid resistant stainless steel

**XLCR 3 TA**

## Mounting tool for slide rail



Mounting tool for slide rail XH

**XHMR 200**

## Aluminium rivets

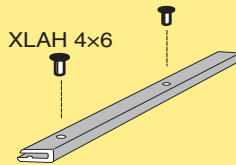

Aluminium rivets 4 mm for X65-X85-XH conveyors

**XLAH 4x6**

Extra slide rail in plain bends must be anchored using plastic screws due to lack of space for the rivet crimping tool.

Note. Contains 250 pcs. 250.

## Plastic screws for slide rail

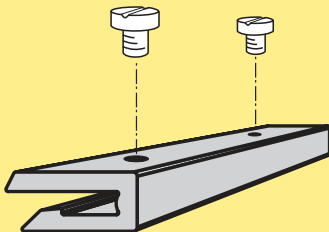

Plastic screws 5 mm for XS-X65-X85-XH-X180/X300 beams

**XLAG 5**

See mounting instruction "Anchoring slide rail using plastic screws" on page 522

Note. Contains 50 pcs.

## Drill fixture for slide rail

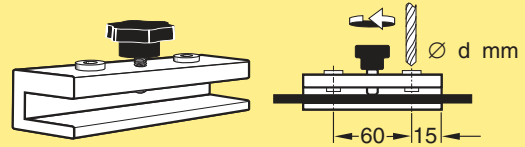

Drill fixture for X65-X85-XH-XK-X180/X300 slide rail

d=4,2 mm

**3920500**

## Rivet crimping pliers



Rivet crimping pliers for X65-X85-XH-XK-X180/X300

For 4 mm rivets

**5051395**

## Rivet crimping clamp

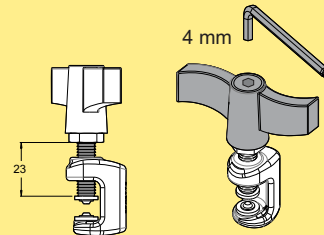

Rivet crimping clamp for X65-X85-XH-XK-X180/X300

For 4 mm rivets

(Allen key not included)

**3923005**

## Cover strip

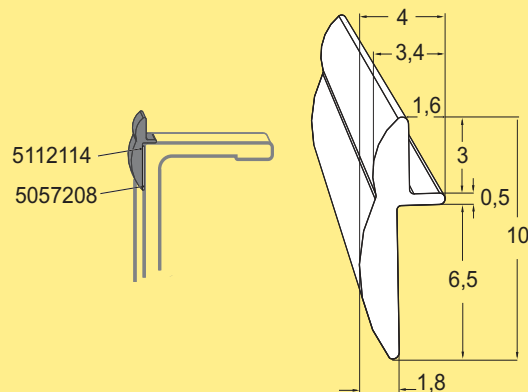

Cover strip

Length: 3 m

Material: Plastic PA 12

**5112114**

Cover the opening on the side between the chain and beam. Primarily for straight sections and the outer curves, but can also be mounted on inner curves. Apply using a double-sided tape, see mounting instruction 5497EN in Technical library.

**Steel slide rail, straight**

Slide rail, hardened steel  
Length 3 m  
**XLCR 3 TH**  
Delivered with 9 predrilled holes

**Brass rivets**

Brass rivets (100 pcs) **5056167**  
Rivets for anchoring the slide rails

**Cleaner 3M**

Cleaner (100 sachets) **5057207**  
Use cleaner on beam and slide rail before attaching glue tape.

**Steel slide rail for bends**

Slide rail for bends, hardened steel  
Slide rail for bend, XH 30° **XHCR W30 TH**  
Slide rail for bend, XH 45° **XHCR W45 TH**  
Slide rail for bend, XH 90° & 180° **XHCR W90 TH**  
180°: Use 2 pieces of steel slide rail 90°

**Glue tape 3M**

Glue tape (for X65, X85, XH)  
Length 30 m **5057208**



# Drive and idler units – introduction

## Drive unit types

The XH system includes several configurations are available, including direct driven units with or without slip clutch. Heavy duty drives with suspended motor and transmission chain can also be ordered.

Available motors include variable speed types (**V**) as well as fixed speed motors (**F**).

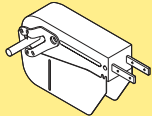
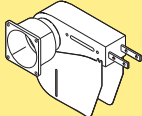
### End drive units

Size	Direct drive, no slip clutch	Direct drive, slip clutch	Suspended motor, transmission chain, slip clutch
			
Heavy	F, V	F, V	F
Heavy, guided	F, V	F, V	–

### Intermediate drive units

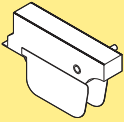
Size	Suspended motor, transmission chain, slip clutch
	
Heavy	F

### Catenary drive units

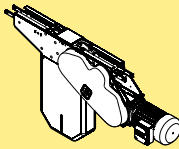
Size	Suspended motor, transmission chain, slip clutch
	
Heavy	F

### Wheel bend drive units

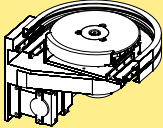
Size	Suspended motor, transmission chain, slip clutch
	
Heavy	F

### Double drive units

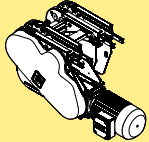
Size	Suspended motor, transmission chain, slip clutch
	
Heavy	F

## Motor specifications

Motors are available for 230/400 V, 50 Hz and 230/460 V, 60 Hz. Variable speed motors are SEW Movimot, 380–500 V. Note that variable speed motors include a control box that adds 120 mm to the width of the motor.

IP55 available with standard oil.

IP65 available with food grade oil.

## Ordering information

Drive units with motors must be specified using the web-based configurator. The configurator provides detailed information and step-by-step guidance in the specification process. A product code string is generated, containing the specification details. See next page for examples of code strings.

Drive units *without* motors can be ordered using the designations in the catalogue.

## Dimension

Note that dimensions relating to drive unit motors depend on the motor specified during the configuration.

# End drive units XH

PO

CC

X45

XS

X65

X65P

X85

X85P

**XH**

XK

XKP

X180

X300

GR

CS

XT

HU

WL

WK

XC

XF

XD

ELV

CTL

FST

TR

APX

IDX

## End drive unit, suspended, slip clutch

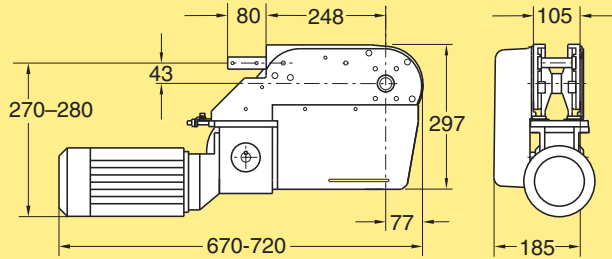

End drive unit  
 Speed up to 60 m/min  
 Transmission on left side  
 Fixed speed\*  
 Without motor (ISO)  
 Without motor (ANSI)

**XHEB**  
**XHEB 0 HL**  
**XHEB 0 HLA**

Maximum traction force: 1250 N. See page 22.  
 \*Use online configurator when ordering.  
 Effective track length: 0,80 m

## End drive unit, suspended, slip clutch

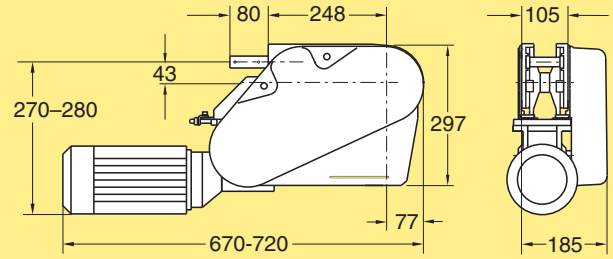

End drive unit  
 Speed up to 60 m/min  
 Transmission on right side  
 Fixed speed\*  
 Without motor (ISO)  
 Without motor (ANSI)

**XHEB**  
**XHEB 0 HR**  
**XHEB 0 HRA**

Maximum traction force: 1250 N. See page 22.  
 \*Use online configurator when ordering.  
 Effective track length: 0,80 m

## End drive units XH, direct drive with slip clutch

### End drive unit, direct drive with slip clutch

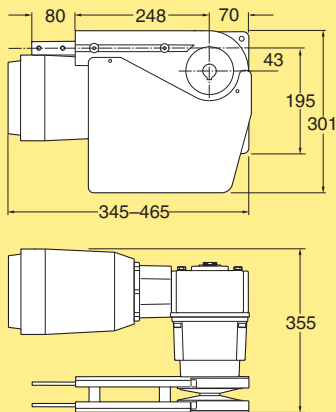

End drive unit, direct drive  
 Fixed speed up to 60 m/min  
 Variable speed: see Drive Unit Guide  
 Motor on left side  
 Fixed/variable speed\*  
 Without motor

**XHEB**  
**XHEB 0 HLP**

Maximum traction force: 1250 N. See page 22.  
 \* Use online configurator when ordering.  
 Effective track length: 0,80 m

### End drive unit, direct drive with slip clutch

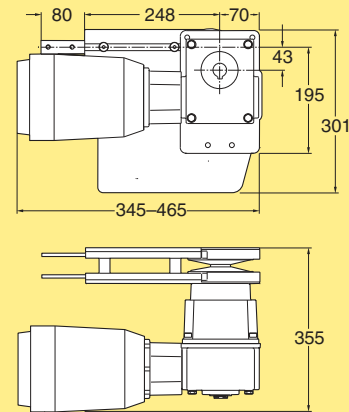

End drive unit, direct drive  
 Fixed speed up to 60 m/min  
 Variable speed: see Drive Unit Guide  
 Motor on right side  
 Fixed/variable speed\*  
 Without motor

**XHEB**  
**XHEB 0 HRP**

Maximum traction force: 1250 N. See page 22.  
 \* Use online configurator when ordering.  
 Effective track length: 0,80 m

# End drive units XH Type H, direct drive, no slip clutch

## End drive unit, direct drive, no slip clutch

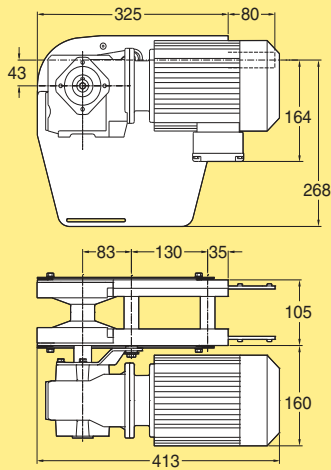

End drive unit, max 1250 N  
 Fixed speed up to 60 m/min  
 Variable speed: see Drive Unit Guide  
 Motor on left side  
 Fixed/variable speed\*  
 Without motor

**XHEB**  
**XHEB 0 HNLP**

Maximum traction force: see diagram, page 22.  
 \*Use online configurator when ordering.  
 Effective track length: 0,80 m

## End drive unit, direct drive, no slip clutch

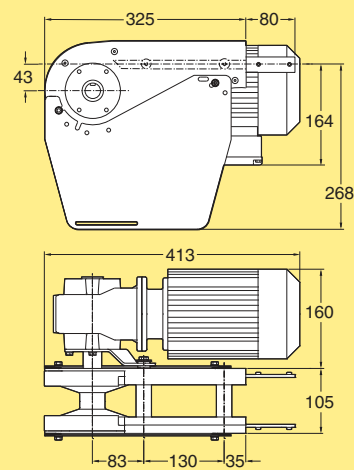

End drive unit, max 1250 N  
 Fixed speed up to 60 m/min  
 Variable speed: see Drive Unit Guide  
 Motor on left side  
 Fixed/variable speed\*  
 Without motor

**XHEB**  
**XHEB 0 HNRP**

Maximum traction force: see diagram, page 22.  
 \*Use online configurator when ordering.  
 Effective track length: 0,80 m

# Double drive units XH

## Double drive unit, suspended

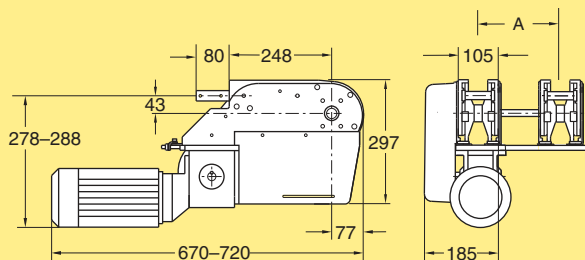

Double drive unit  
 Suspended motor  
 Fixed speed up to 60 m/min  
 Transmission on left side  
 A = 106 mm  
 Fixed speed\*  
 Without motor (ISO)  
 Without motor (ANSI)

**XHEB DD**  
**XHEB 0 HLD106**  
**XHEB 0 HLD106**

A = 150-350 mm  
 Without motor (ISO)  
 Without motor (ANSI)

**XHEB 0 HLD-**  
**XHEB 0 HLD-**

Maximum traction force: 1250 N. See page 22.  
 \* Use online configurator when ordering.  
 Effective track length: 0,80 m

## Double drive unit, suspended

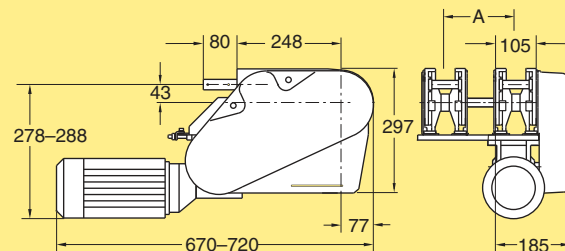

Double drive unit  
 Suspended motor  
 Fixed speed up to 60 m/min  
 Transmission on right side  
 A = 106 mm  
 Fixed speed\*  
 Without motor (ISO)  
 Without motor (ANSI)

**XHEB DD**  
**XHEB 0 HRD106**  
**XHEB 0 HRD106**

A = 150-350 mm  
 Without motor (ISO)  
 Without motor (ANSI)

**XHEB 0 HRD-**  
**XHEB 0 HRD-**

Maximum traction force: 1250 N. See page 22.  
 \* Use online configurator when ordering.  
 Effective track length: 0,80 m

# Intermediate drive units XH

**Intermediate drive unit**

Intermediate drive unit  
Suspended motor  
Fixed speed up to 25 m/min  
Transmission on left side  
Fixed speed\*  
Without motor (ISO)  
Without motor (ANSI)

**XHER**  
**XHER 0 HL**  
**XHER 0 HLA**

*Maximum traction force: 200 N. See page 22.*  
*\* Use online configurator when ordering.*  
*Effective track length: 1,00 m*

**Intermediate drive unit**

Intermediate drive unit  
Suspended motor  
Fixed speed up to 25 m/min  
Transmission on right side  
Fixed speed\*  
Without motor (ISO)  
Without motor (ANSI)

**XHER**  
**XHER 0 HR**  
**XHER 0 HRA**

*Maximum traction force: 200 N. See page 22.*  
*\*Use online configurator when ordering.*  
*Effective track length: 1,00 m*

# Catenary drive units XH

**Catenary drive unit**

Catenary drive unit  
Suspended motor  
Fixed speed up to 25 m/min  
Transmission on left side  
Fixed speed\*  
Without motor (ISO)  
Without motor (ANSI)

**XHEC**  
**XHEC 0 HL**  
**XHEC 0 HLA**

*Maximum traction force: 1250 N. See page 22.*  
*\*Use online configurator when ordering.*  
*Effective track length: 1,35 m*

**Catenary drive unit**

Catenary drive unit  
Suspended motor  
Fixed speed up to 25 m/min  
Transmission on right side  
Fixed speed\*  
Without motor (ISO)  
Without motor (ANSI)

**XHEC**  
**XHEC 0 HR**  
**XHEC 0 HRA**

*Maximum traction force: 1250 N. See page 22.*  
*\*Use online configurator when ordering.*  
*Effective track length: 1,35 m*

- PO
- CC
- X45
- XS
- X65
- X65P
- X85
- X85P
- XH**
- XK
- XKP
- X180
- X300
- GR
- CS
- XT
- HU
- WL
- WK
- XC
- XF
- XD
- ELV
- CTL
- FST
- TR
- APX
- IDX

# Bend drive unit XH

## Bend drive unit, 180°

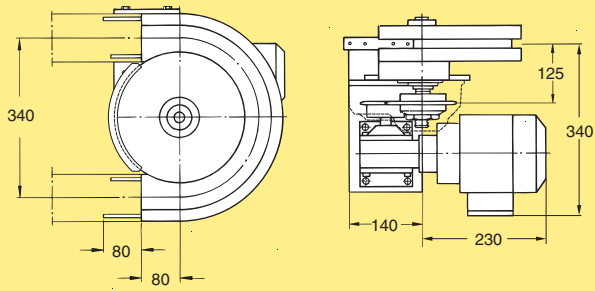

Bend drive unit, 180°  
 Fixed speed up to 30 m/min  
 Fixed speed\*  
 Without motor (ISO)  
 Without motor (ANSI)

**XHEW**  
**XHEW 180/0 H**  
**XHEW 180/0 HA**

Maximum traction force: 200 N. See page 22.  
 \*Use online configurator when ordering.  
 Effective track length: 0,65 m

# Idler units XH

## Idler end unit

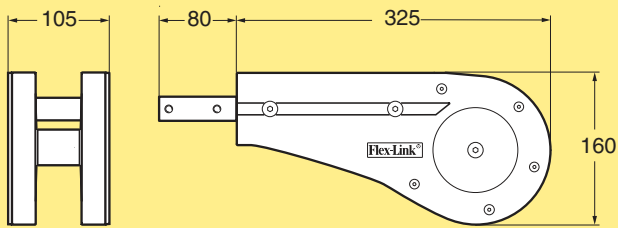

Idler end unit  
 Effective track length: 0,80 m

**XHEJ 325**

## Idler bend unit, 90°

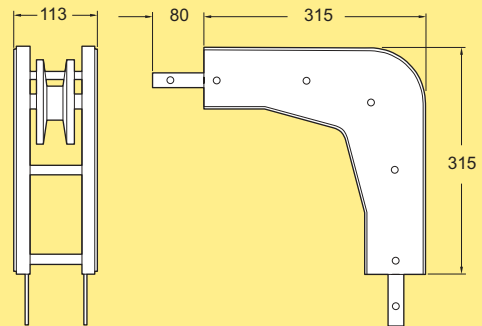

Idler bend unit, 90°  
 Effective track length: 0,65 m.  
 Note. Cannot be used with return chain.

**XHEK 90R50**

## Protective cover for idler end unit

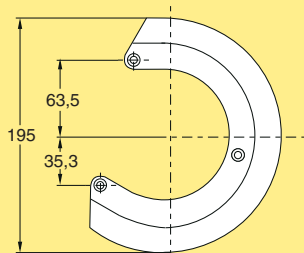

Protective cover for idler end unit **XHSJ 195**

**Passive bridge from conveyor to conveyor**

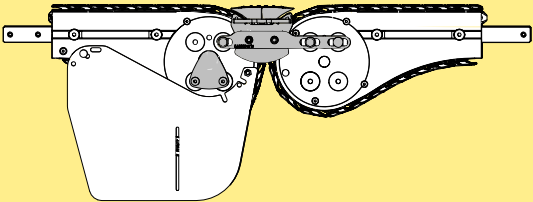

*Passive bridge\** **XHNG**

From: Heavy Drive To: Heavy Idler

*\* Use online configurator when ordering.*

**Passive bridge to or from machine or application, Single or double rollers**

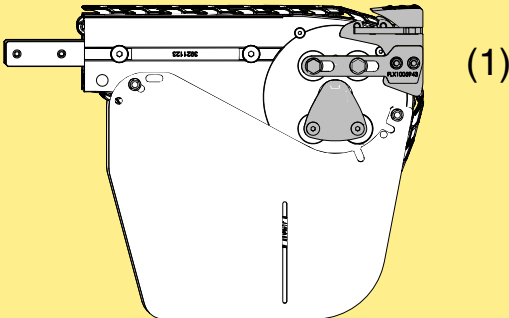

(1)

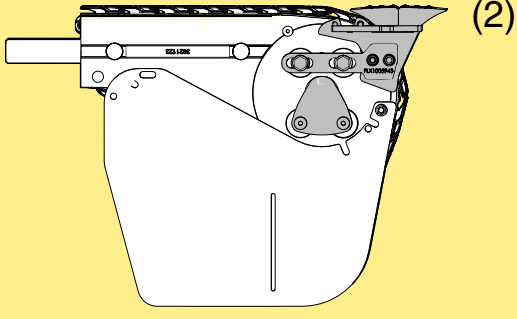

(2)

*Passive bridge\**  
Single roller (1) or Double roller (2) **XHNG**

From: Heavy Drive To: External  
External Heavy Idler

*\* Use online configurator when ordering.*

**Attachment wire**



Wire for attaching roller to holder **FLX1006041**

*\*Also available as a configuration option through XHNG.*

**Sensor Kit**

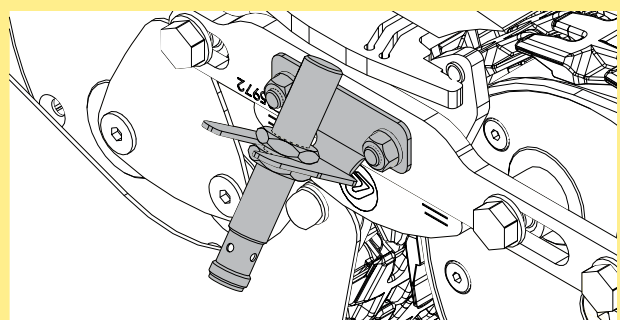

Bridge in position sensor kit  
Conveyor to conveyor **FLX1006042**  
External to/from Conveyor **FLX1006044**

*\*Also available as a configuration option through XHNG.*

*\*Note*  
Bridges can not be used with cleated chain.

**S-Transfer**

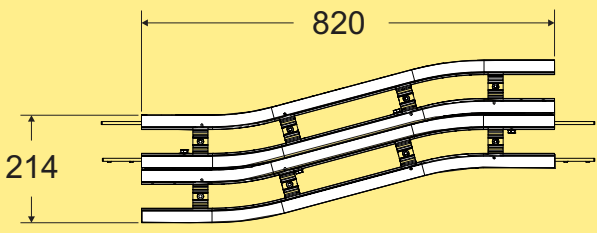

S-transfer for return chain  
for XH **XHCY D**

*Effective track length: 3,3 m*

# Wheel bends XH

**Wheel bend, 30°**

Wheel bend, 30° **XHBH 30R170 A**  
 Effective track length: 0,25 m 1-way (0,50 m 2-way)

**Wheel bend, 45°**

Wheel bend, 45° **XHBH 45R170 A**  
 Effective track length: 0,30 m 1-way (0,60 m 2-way)

**Wheel bend, 90°**

Wheel bend, 90° **XHBH 90R170 A**  
 Effective track length: 0,40 m 1-way (0,80 m 2-way)

**Wheel bend, 180°**

Wheel bend, 180° **XHBH 180R170 A**  
 Effective track length: 0,65 m 1-way (1,30 m 2-way)

**Wheel bend, 210°**

Wheel bend, 210° **XHBH 210R170 A**  
 Effective track length: 0,80 m 1-way (1,60 m 2-way)

**Wheel bend, 30°–180°**

Wheel bend, 30°–180° **XHBH ER170 A**  
 The outer bend is cut in the middle to the desired angle and assembled using connecting strips. The angle "E" must be specified when ordering.

# Wheel cover for Wheel bend

PO

CC

X45

XS

X65

X65P

X85

X85P

**XH**

XK

XKP

X180

X300

GR

CS

XT

HU

WL

WK

XC

XF

XD

ELV

CTL

FST

TR

APX

IDX

**Wheel cover for X65/XL, XT, X85, XH**

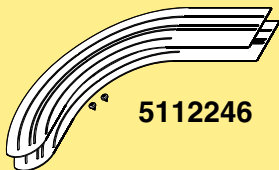

**5112246**

Wheel cover for X65/XL, XT, X85, XH **5112246**  
 (Including one pair of Wheel cover 5112244 and 2 tap screw ISO 7049 4,2x6,5-C-H-A2K)

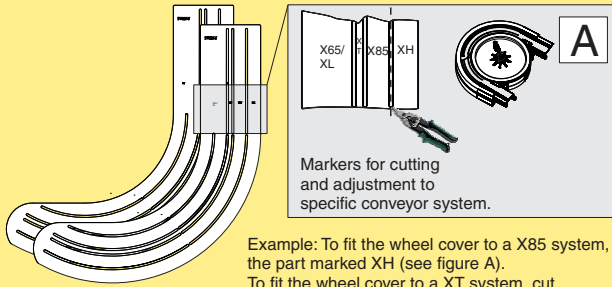

Markers for cutting and adjustment to specific conveyor system.

Example: To fit the wheel cover to a X85 system, cut the part marked XH (see figure A).  
 To fit the wheel cover to a XT system, cut the parts marked X85 and XH.

## Plain bends XH

**Plain bend, 30°**

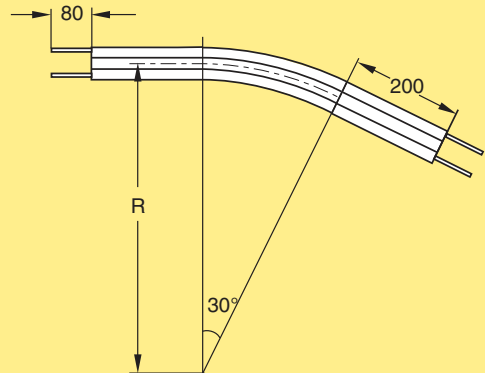

Plain bend, 30°±1°  
 R=500±10 mm **XHBP 30R500**  
 R=700±10 mm **XHBP 30R700**  
 R=1000±10 mm **XHBP 30R1000**

*Effective track lengths:*  
 R500: 0,70 m 1-way (1,35 m 2-way)  
 R700: 0,80 m 1-way (1,55 m 2-way)  
 R1000: 0,95 m 1-way (1,85 m 2-way)

**Plain bend, 60°**

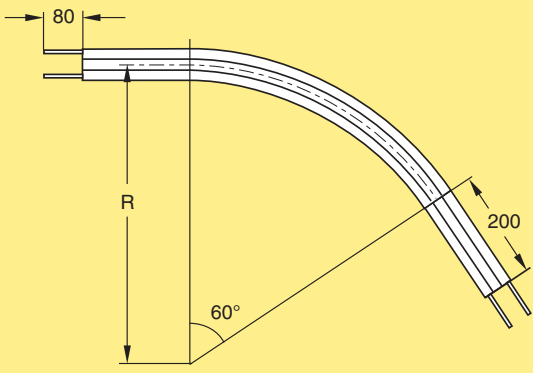

Plain bend, 60°±1°  
 R=500±10 mm **XHBP 60R500**  
 R=700±10 mm **XHBP 60R700**  
 R=1000±10 mm **XHBP 60R1000**

*Effective track lengths:*  
 R500: 0,95 m 1-way (1,85 m 2-way)  
 R700: 1,15 m 1-way (2,30 m 2-way)  
 R1000: 1,45 m 1-way (2,90 m 2-way)

## Plain bends XH (continued)

### Plain bend, 45°

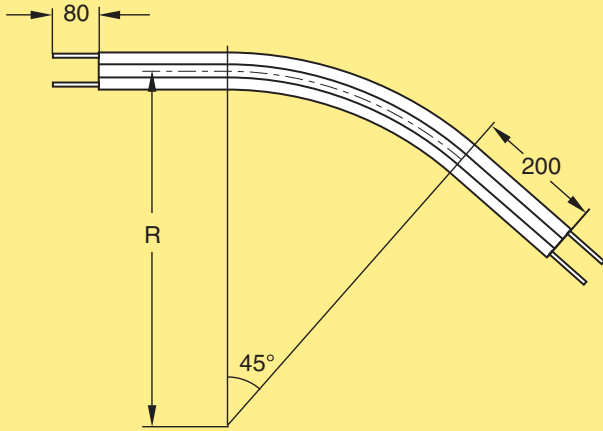

Plain bend, 45°±1°

R=500±10 mm

R=700±10 mm

R=1000±10 mm

**XHBP 45R500**  
**XHBP 45R700**  
**XHBP 45R1000**

*Effective track lengths:*

*R500: 0,80 m 1-way (1,60 m 2-way)*

*R700: 0,95 m 1-way (1,90 m 2-way)*

*R1000: 1,20 m 1-way (2,40 m 2-way)*

### Plain bend, 90°

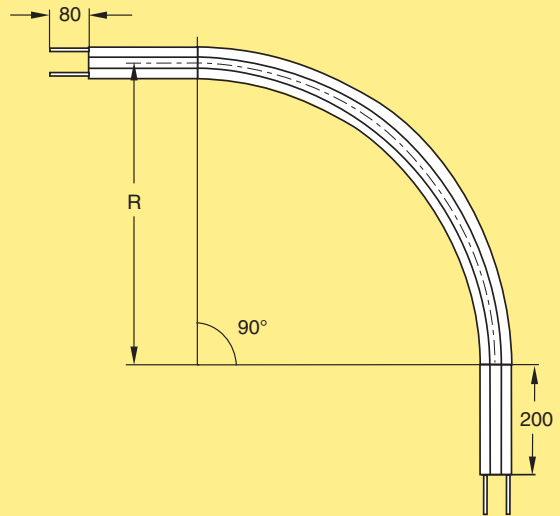

Plain bend, 90°±1°

R=500±10 mm

R=700±10 mm

R=1000±10 mm

**XHBP 90R500**  
**XHBP 90R700**  
**XHBP 90R1000**

*Effective track lengths:*

*R500: 1,20 m 1-way (2,40 m 2-way)*

*R700: 1,50 m 1-way (3,00 m 2-way)*

*R1000: 2,00 m 1-way (3,95 m 2-way)*

## Support rail for plain bends XH

### Support rail for plain bends

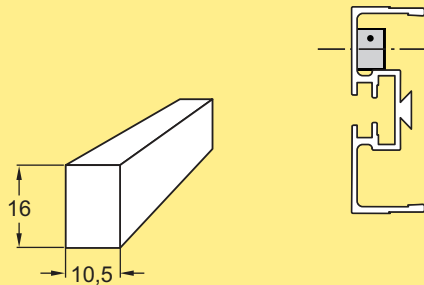

Support rail for plain bends, XH

Length 2,4 m

**5048598**

*Fix with sheet metal screw ISO 7049 4,2×9,5 or similar.  
 See page 521 for installation instructions.*

**Vertical bend, 5°**

Vertical bend, 5° **XHBV 5R400**  
 Effective track length: 0,20 m 1-way (0,40 m 2-way)

**Vertical bend, 45°**

Vertical bend, 45°  
 R= 400, A=419, B=174 **XHBV 45R400**  
 R=1000, A=844, B=349 **XHBV 45R1000**  
 Effective track length:  
 R400: 0,50 m 1-way (0,95 m 2-way)  
 R1000: 0,95 m 1-way (1,90 m 2-way)

**Vertical bend, 7°**

Vertical bend, 7° **XHBV 7R400**  
 Effective track length: 0,20 m 1-way (0,45 m 2-way)

**Vertical bend, 60°**

Vertical bend, 60° **XHBV 60R400**  
 Effective track length: 0,65 m 1-way (1,20 m 2-way)

**Vertical bend, 15°**

Vertical bend, 15° **XHBV 15R400**  
 Effective track length: 0,30 m 1-way (0,55 m 2-way)

**Vertical bend, 90°**

Vertical bend, 90°  
 R= 400, A= 480 **XHBV 90R400**  
 R=1000, A=1080 **XHBV 90R1000**  
 Effective track length:  
 R400: 0,85 m 1-way (1,60 m 2-way)  
 R1000: 1,75 m 1-way (3,50 m 2-way)

**Vertical bend, 30°**

Vertical bend, 30° **XHBV 30R400**  
 Effective track length: 0,40 m 1-way (0,75 m 2-way)

## Vertical bends XH (continued)

### Vertical bend, 5°–90°

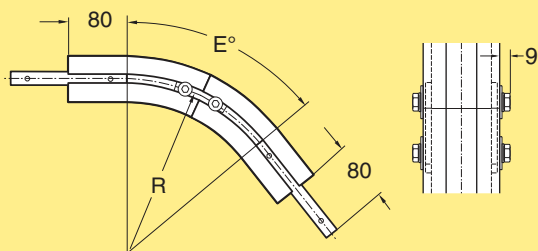

Vertical bend, 5°–90°

R=400

R=1000

**XHBV ER400**  
**XHBV ER1000**

*The bend is cut in the middle to the desired angle and assembled using connecting strips. The angle "E" must be specified when ordering.*

## Angle plates XH

### Angle plate, straight

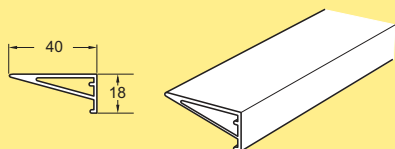

Angle plate  
Length 3 m

**XHRP 3**

### Angle plate for 90° bend

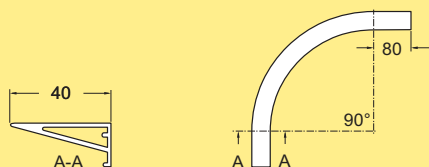

Angle plate for 90° bend  
Used with XHBH 90R170  
Inner radius 222,5 mm

**XHRM 90**

### Angle plate for 180° bend

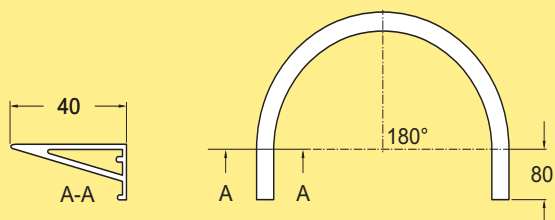

Angle plate for 180° bend  
Used with XHBH 180R170 and  
XHEW 180/5 H  
Inner radius 222,5 mm

**XHRM 180**

**Front piece**

Front piece  
Length 3 m

**XHVF 3**

**Sliding strip for front piece**

Sliding strip for front piece  
Length 2 m

**XHVG 2**

**Linkage kit for front piece**

Linkage kit  
W=190, D=43  
W=290, D=93

**XHVK 43**  
**XHVK 93**

*Kit consists of two support pairs.*

**Bend support for front piece**

Bend support  
D=43 mm  
D=93 mm

**XHVS 43**  
**XHVS 93**

**Front piece upper bend**

Upper bend, 60°

**XHVA 60R460**

*Includes connecting strip with screws*

**Front piece lower bend**

Lower bend, 60°

**XHVB 60R335**

*Includes connecting strip with screws*

## Drip trays XH

### Drip tray

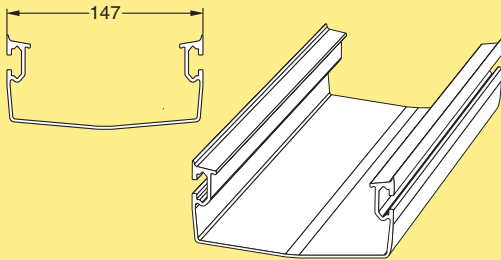

Drip tray  
Length 3 m

**XHDT 3x147 B**

### Drip tray bracket

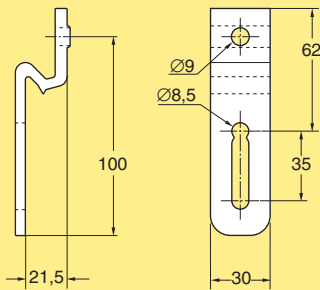

Drip tray bracket

**XLDB 21x100**

### Connecting strip

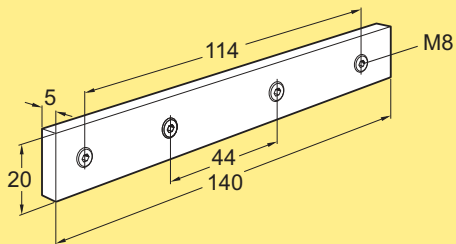

Connecting strip with set screws **XLCJ 5x140**

*Note. Contains 10 pcs.*

## Drip catcher 53 mm

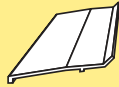
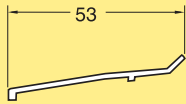

Drip catcher 53 mm  
Length 3 m

**XHDS 3×53**

## Drip catcher 83 mm

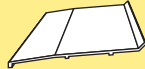
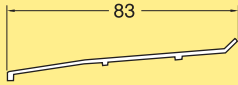

Drip catcher 83 mm  
Length 3 m

**XHDS 3×83**

## Drip catcher bracket assembly

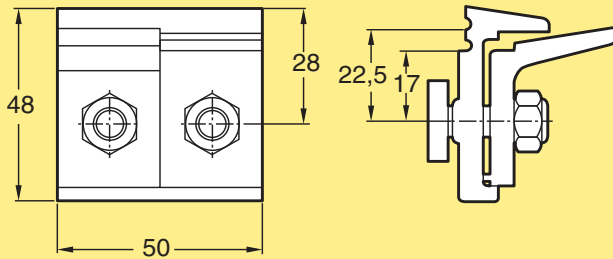

Drip catcher bracket assembly  
*Including T-bolts and nuts*

**XHDR 23**

