

UD18-22CC221

UD18

FORK SENSORS

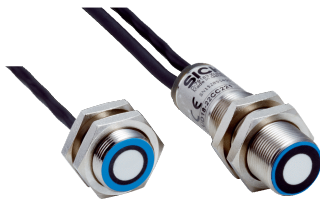
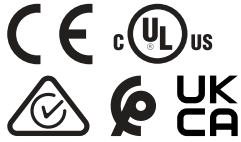

Illustration may differ



Ordering information

Type	part no.
UD18-22CC221	6058910

Other models and accessories →

Detailed technical data

Features

Functional principle	Ultrasonic detection principle
Housing design	Cylindrical
Dimensions (W x H x D)	18 mm x 18 mm x 63.2 mm
Installation distance	20 mm ... 60 mm, 40 mm ± 3 mm (default setting)
Fork width	60 mm (corresponds to installation distance max.)
Blind zone	7 mm ... 7 mm (from sender and receiver)
Permissible angle deviation	± 45° perpendicular to material layer
Detectable material	Paper with grammages: 20 g/m ² ... 2,000 g/m ² Plastic sheets and foils: ≤ 0.4 mm Self-adhesive films, metal sheets: ≤ 0.3 mm Corrugated cardboard: single wall F, N and G flute sizes Washi Wafer PCB
Label detection	✓
Resolution	1 material layer
Display	2 x LED
Adjustment	Cable (Control inputs C1, C2, C3)
Additional function	3 selectable sensitivity levels Teach-in of up to 4 individual sensitivity level Sensitivity level changeover during operation Configurable via IO-Link, SOPAS and Connect+ software
Output time	2 ms, trigger mode: < 0.5 ms
Safety-related parameters	
	MTTF _D 101 years

Interfaces

Digital output	Q ₁ , Q ₂
Number	2 ¹⁾ 2 ²⁾
Type	PNP

¹⁾ Outputs Q₁ and Q₂ short-circuit protected.

²⁾ PNP: Active = V_s - (< 2 V) / Inactive = 0 V.

Function	Q ₁ : switching output double layer, Q ₂ : switching output single / no layer, normally closed
Maximum output current I _A	≤ 200 mA
Control input	3 x (Active ≥ 18 V, Inactive ≤ 13 V or Inputs Unswitched)

¹⁾ Outputs Q₁ and Q₂ short-circuit protected.

²⁾ PNP: Active = V_S - (< 2 V) / Inactive = 0 V.

Electronics

Supply voltage	20 V DC ... 30 V DC ¹⁾
Ripple	± 10 %
Current consumption	50 mA ²⁾
Power consumption	≤ 1.5 W ²⁾
Initialization time	< 300 ms
Ultrasonic frequency	400 Hz
Switching frequency	250 Hz
Response time	2.5 ms
Switching output	PNP
Switching output (voltage)	PNP: HIGH = V _S - 3 V / LOW = 0 V
Output current I_{max}	≤ 100 mA
Protection class	III ³⁾
Circuit protection	U _V connections, reverse polarity protected Output Q short-circuit protected
Connection type	
Supply voltage & I/O	Cable open end, 7-wire, 2 m
Connection type Detail	
Length of cable	2 m
Cable material	PUR
Cable diameter	4.4 mm
Conductor cross section	0.25 mm ²
Pinouts for Supply voltage & I/O	
BN	+ (L+)
BK	Q ₁ / Q ₁
BU	- (M)
WH	Q ₂ / Q ₂
VT	C1
PK	C2
GY	C3/COM

¹⁾ Limit values, reverse-polarity protected, operation in short-circuit protected network: max. 8 A.

²⁾ Without load.

³⁾ Reference voltage DC 50 V.

Mechanics

Sending axis	Straight
Thread size	M18 x 1

Housing material	Nickel-plated brass, PBT/PA
Sensing face material	Ultrasonic transducer: polyurethane foam, glass epoxy resin
Weight	Approx. 130 g

Ambient data

Ambient operating temperature	+5 °C ... +60 °C
Ambient temperature, storage	-40 °C ... +85 °C
Shock load	According to EN 60068-2-27
EMC	EN 60947-5-2 ¹⁾
Enclosure rating	IP65
UL File No.	NRKH.E191603 & NRKH7.E191603

¹⁾ The sensor complies with the electromagnetic compatibility (EMC) requirements for the industrial sector (Radio Safety Class A).

Classifications

ECLASS 5.0	27270909
ECLASS 5.1.4	27270909
ECLASS 6.0	27270909
ECLASS 6.2	27270909
ECLASS 7.0	27270909
ECLASS 8.0	27270909
ECLASS 8.1	27270909
ECLASS 9.0	27270909
ECLASS 10.0	27270909
ECLASS 11.0	27270909
ECLASS 12.0	27270909
ETIM 5.0	EC002720
ETIM 6.0	EC002720
ETIM 7.0	EC002720
ETIM 8.0	EC002720
UNSPSC 16.0901	39121528

Certificates

EU declaration of conformity	✓
UK declaration of conformity	✓
ACMA declaration of conformity	✓
Moroccan declaration of conformity	✓
China RoHS	✓
cULus certificate	✓

Dimensional drawing, sensor

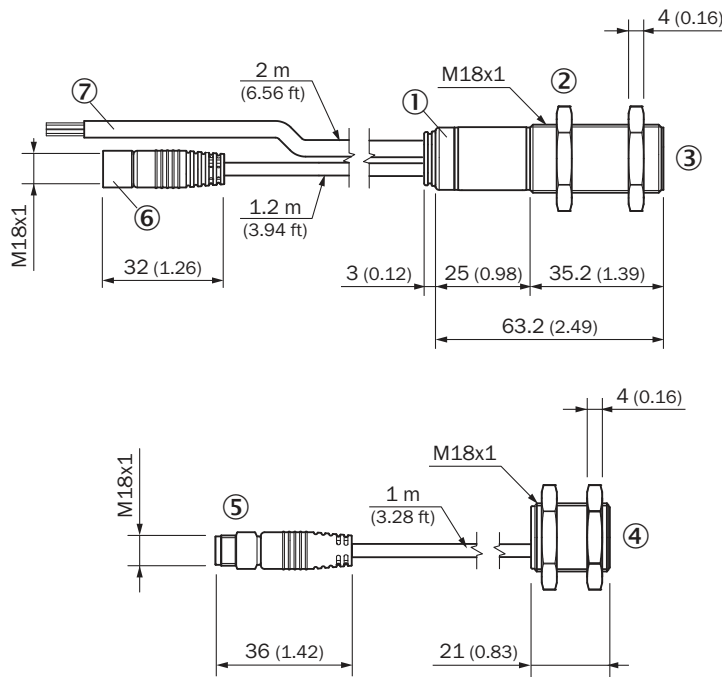

Dimensions in mm (inch)

- ① LED status indicator
- ② Fixing nuts, width 24 mm
- ③ receiver with evaluation unit
- ④ sender
- ⑤ plug M8x1, 3-pin, for connection with the receiver
- ⑥ female connector M8x1, 3-pin, for connection with the sender
- ⑦ supply voltage and controls connection cable

Pinouts, see table Technical data: Electronics

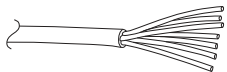

cable open end, 7-wire

connection diagram

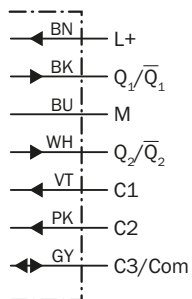

supply voltage & I/O: cable open end, 7-wire

connection example

