

Original Manual

# Protection System E16x356

with  
Overspeed Protection  
and  
Voters for external Trip Conditions

Certified by TÜV for  
IEC61508; SIL3  
DIN EN ISO 13849-1:2008; Cat.3 PLe

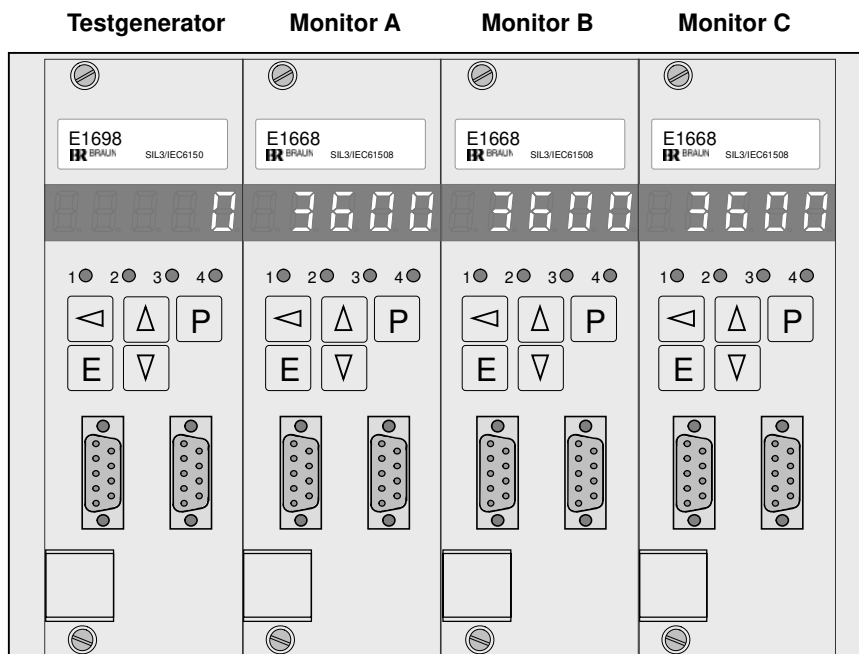

Figure 1: E16x356 System Front View

## Table of Contents

Content	Page
<b>Table of Contents</b> .....	<b>2</b>
<b>1 General Informations</b> .....	<b>5</b>
1.1 List of Figures.....	5
1.2 List of Abbreviations .....	6
1.3 System Applications and Definitions.....	8
1.3.1 System Applications.....	8
1.3.2 Definition of Terms.....	8
1.4 Key Features of System E16x356.....	9
1.5 Ordering Key for Systems E16x356.abc .....	10
1.6 Certifications.....	11
1.6.1 Certification IEC61508; SIL3 .....	11
1.6.2 Certification DIN EN ISO 13849-1:2008; Cat.3 PLe .....	11
1.7 Safety Data.....	13
1.7.1 Safety Data IEC61508; SIL3.....	13
1.7.2 Safety Data DIN EN ISO 13849-1:2008; Cat.3 PLe.....	13
<b>2 System Structure and I/Os</b> .....	<b>14</b>
2.1 System Structure.....	14
2.1.1 Speed Sensors .....	14
2.1.2 System Components .....	14
2.1.3 System Design .....	14
2.1.4 System Structure Diagrams.....	15
2.1.5 System Wiring Diagrams .....	17
2.1.6 Connection of Sensors to the Speed Signal Inputs .....	19
2.2 Inputs of the System.....	20
2.2.1 Speed Signal .....	20
2.2.2 Rotation Direction Signal (F/R: Forward/Reverse).....	20
2.2.3 Reset of Alarms .....	20
2.2.4 Test Lock .....	20
2.2.5 Start Auto Test Sequence .....	20
2.2.6 Test I, Test II, Test III.....	21
2.2.7 Starter (Override of SP2).....	21
2.2.8 SP1B Valid.....	21
2.2.9 Feedback inputs of the 2oo3 solenoid valve block .....	21
2.2.10 External Signals for Voter 1 .....	21
2.2.11 External Signals for Voters 2 ... 6.....	21
2.3 Outputs of the System.....	22
2.3.1 System Warning Alarm 1 and System Warning Alarm 2 .....	22
2.3.2 Speed Signal Repeater.....	22
2.3.3 Monitor Warning Alarm .....	22
2.3.4 Speed Alarm SP3 .....	23
2.3.5 Analog Outputs proportional to measured speed (Option).....	23
2.3.6 Rotation Direction Detection.....	23
2.3.7 Speed Trip Logic Output (2oo3 voted).....	23
2.3.8 Trip Lines IV, V, VI .....	23
2.3.9 Trip Lines I, II, III.....	23
2.3.10 Logic Outputs LO1 through LO6 (voted 2oo3).....	23
2.4 Power Supply .....	24
2.4.1 Power Supply of Monitors E1668 and Testgenerator E1698 .....	24

2.5	Data Interface.....	24
2.5.1	PROFIBUS Interface for Status and Diagnostics of the System.....	24
2.5.2	RS232 Interface for Setting of Parameters.....	24
<b>3</b>	<b>Technical Specifications.....</b>	<b>25</b>
3.1	Technical Data of Inputs.....	25
3.1.1	Technical Data of Speed Signal Inputs.....	25
3.1.1.1	Hall Sensor Inputs.....	25
3.1.1.2	Eddy Current Sensor Inputs or MPU (Magnetic Pickup) Inputs.....	25
3.1.2	Technical Data of Rotation Direction Inputs.....	25
3.1.3	Technical Data of Binary Inputs (excluding Voter 1).....	25
3.1.4	Technical Data of Binary Inputs of Voter 1.....	25
3.1.5	Chapter left blank intentionally.....	25
3.1.6	Chapter left blank intentionally.....	25
3.1.7	Chapter left blank intentionally.....	25
3.1.8	Chapter left blank intentionally.....	26
3.1.9	Chapter left blank intentionally.....	26
3.1.10	Technical Data of Inputs Starter.....	26
3.2	Technical Data of Outputs.....	27
3.2.1	Technical Data of Speed Sensor Signal Repeater Outputs.....	27
3.2.2	Technical Data of Analog Outputs.....	27
3.2.3	Technical Data of Opto Relay Outputs.....	27
3.2.4	Technical Data of Logic Outputs.....	27
3.2.5	Technical Data of Trip Lines IV, V, VI.....	27
3.2.6	Technical Data of Trip Lines I, II, III.....	27
3.3	Technical Data of Power Supplies.....	28
3.3.1	Technical Data of Power Supply of Monitors E1668 and Testgenerator E1698.....	28
3.4	Amount of Heat to be dissipated.....	28
3.5	Installation Conditions.....	28
3.6	Protection Grade.....	28
3.7	Connectors.....	28
3.7.1	Connectors with Pull Spring Terminals.....	28
3.7.2	Chapter left blank intentionally.....	29
3.8	Conformity to Standards.....	29
3.9	Useful Lifetime, Proof Test Interval and Maintenance of the E16x356 System.....	29
3.10	Dimensions of System E16A356.....	30
3.11	Dimensions of System E16E356.....	31
3.12	Chapter left blank intentionally.....	32
3.13	Weight of E16x356.....	32
3.14	Material specifications of E16A356 or E16E356.....	32
3.15	Total Front View with Location of Terminals of E16A356.....	33
<b>4</b>	<b>Safety Notes for Installation and Operation.....</b>	<b>34</b>
4.1	Safety Notes for Installation.....	34
4.1.1	General Instructions.....	34
4.1.2	EMI.....	34
4.2	Safety Notes for Operation.....	34
4.2.1	Safety Notes on Commissioning.....	34
<b>5</b>	<b>Description of Monitor E1668.....</b>	<b>35</b>
5.1	Display and Frontside Operational Elements.....	35
5.1.1	Front View of Monitor E1668.....	35
5.1.2	Status-LEDs.....	35
5.1.3	Display during Test Procedures.....	35

5.1.4	Values accessible during normal operation .....	36
5.1.5	Special Display Mode 1 .....	36
5.1.6	Special Display Mode 2 .....	36
5.1.7	Display of Firmware release state and CRC-Parameter-Checksum of Monitor .....	36
5.1.8	Frontside Reset of Alarms and Event codes .....	37
5.1.9	Data Interface .....	37
5.2	Functions of Monitor E1668 .....	38
5.2.1	Speed Measurement .....	38
5.2.2	Functions for Overspeed Protection .....	38
5.2.3	Functions for External Trip by Voters .....	38
5.2.4	Permanent Monitoring Functions .....	38
5.2.5	Functional Tests .....	38
5.2.6	Selftest of Monitor .....	38
<b>6</b>	<b>Description of Testgenerator E1698 .....</b>	<b>40</b>
6.1	Display and Frontside Operational Elements .....	40
6.1.1	Front View of Testgenerator E1698 .....	40
6.1.2	Status-LEDs .....	40
6.1.3	Display during Test Procedures .....	41
6.1.4	Values accessible during normal operation .....	41
6.1.5	Display of Firmware release state and CRC-Parameter-Checksum of Monitor .....	41
6.1.6	Frontside Reset of Alarms and Event codes .....	41
6.1.7	Manual Start of a Monitor-Test Sequence .....	41
6.1.8	Manual Start of a Trip-Line-Test Sequence .....	41
6.1.9	Data Interface .....	41
6.2	Functions of Testgenerator 1698 .....	42
6.2.1	Permanent Monitoring of Feedbacks .....	42
6.2.2	Monitor-Test Sequence .....	42
6.2.3	Trip-Line-Test Sequence (Test of 2oo3 Solenoid Valve Block) .....	43
6.2.4	Cross-check between CPUs of Test-Generator .....	43
6.2.5	Selftest of CPUs .....	43
<b>7</b>	<b>Chapter left blank intentionally .....</b>	<b>44</b>
<b>8</b>	<b>Programming of the Modules .....</b>	<b>45</b>
8.1	Programming of the Modules via Front Keyboard .....	45
8.2	Programming of the Modules via RS232-Interface .....	46
8.3	Default Values .....	46
8.4	Response of Parameter if range of values is exceeded .....	46
8.5	Display of Parameter Values if front side parameter access is locked .....	46
8.6	Safety Notes for Parameter Access during operation of the machine .....	46
<b>9</b>	<b>Parameters of Monitor E1668 .....</b>	<b>47</b>
9.1	Summary of parameters and their default values .....	47
9.2	Description of Parameters and their Settings of Monitor E1668 .....	51
<b>10</b>	<b>Parameters of Test-Generator E1698 .....</b>	<b>79</b>
10.1	Summary of parameters and their default values .....	79
10.2	Description of Parameters and their Settings of Test-Generator E1698 .....	80
<b>11</b>	<b>Event codes and Troubleshooting .....</b>	<b>87</b>
11.1	Event codes on display of Monitor E1668 .....	87
11.2	Troubleshooting if display of Monitor reads E.0.4.0.0 .....	89
11.3	Event codes on display of Testgenerator E1698 .....	90
	Event codes on display of E1698 (continued) .....	91
<b>12</b>	<b>Revision Notes .....</b>	<b>92</b>

# 1 General Informations

## 1.1 List of Figures

Figure 1:	E16x356 System Front View.....	1
Figure 2:	E16x356 System Structure Diagram 1 of 2 : Testgenerator and speed section of Monitors .....	15
Figure 3:	E16x356 System Structure Diagram 2 of 2 : Voter section of Monitors .....	16
Figure 4:	E16x356 System Wiring Diagram 1 of 3 : Testgenerator and speed section of Monitors.....	17
Figure 5:	E16x356 System Wiring Diagram 2 of 3 : Voter section of Monitors.....	18
Figure 6:	E16x356 System Wiring Diagram 3 of 3 : Connection of speed sensors.....	19
Figure 7:	Dimensions of System E16A356 .....	30
Figure 8:	Dimensions of System E16E356 .....	31
Figure 9:	Left blank intentionally .....	32
Figure 10:	Total Front View with Location of Terminals .....	33
Figure 11:	Front View of Monitor E1668 .....	35
Figure 12:	Front View of Testgenerator E1698 .....	40
Figure 13:	SP1 as a variable of the acceleration .....	59

## 1.2 List of Abbreviations

Abbreviation	Meaning
altern.	alternative
API	Technical standards of the "American Petroleum Institute"
A5S	BRAUN GmbH Sensor series
AWG/kcmil	Code number according to the "American Wire Gauge" System
approx.	approximately
CH1	Channel 1
CH2	Channel 2
CH3	Channel 3
CCF	Common Cause Failure
CPU	Central Processing Unit
DCavg	Diagnostic Coverage average
DCS	Distributed Control System
DIN	Deutsches Institut für Normung (German Institute for Standardization)
dn/dt	Change of speed per time unit (Acceleration)
EEPROM	Electrically Erasable Programmable Read Only Memory
EMV	Electro magnetic compatibility
EN	European Norm
F/R	Forward/Reverse (Forward/Backward)
HE	Height units
HFT	Hardware Fault Tolerance
IEC	International Electrotechnical Commission
incl.	inclusive
IPxx	Ingress Protection Number xx according to DIN EN 60529
ISO	International Organization for Standardization
LED	Light Emitting Diode
LOx	Logic Output x
max.	maximum
min.	minimum
MPU	Magnetic Pick Up
MTTFd	Mean Time To dangerous Fault
MTTR	Mean Time to Restoration
Moo3	Median out of 3 selection logic
n	Short term for Speed
NEMAx	National Electrical Manufacturers Association Number x
PFDavg	Probability of Fault on Demand average
PELV	Protective Extra Low Voltage
PLC	Programmable Logic Controller
RAM	Random Access Memory
RPM	Revolutions Per Minute
sec	second
SELV	Safety Extra Low Voltage
SFF	Safe Failure Fraction
SILx	Safety Integrity Level x
SPx	SetPoint x
SPVx	SetPoint Voter x
SP1var	SetPoint 1 variable
	continued on next page

<b>Abbreviation</b>	<b>Meaning</b>
TE	Width unit
TMR	Triple Modular Redundant
Tproof	Proof Test Interval
UL/cUL	Acc. US Underwriter Laboratories or Canadian Underwriter Laboratories standards
VCC	Valve Control Circuit
VCM	Valve Control Module
Vdc	Volt direct current
Vpp	Volt peak-to-peak
1oo2	1 out of 2 voting logic
1oo3	1 out of 3 voting logic
2oo2	2 out of 2 voting logic
2oo3	2 out of 3 voting logic

## **1.3 System Applications and Definitions**

### **1.3.1 System Applications**

Protection of rotating machinery such as turbines, expanders, compressors and motors with safety requirements SIL3/IEC61508 and DIN EN ISO 13849:2008 Cat.3 PLe and/or API 670 versus Overspeed and other Critical Conditions.

### **1.3.2 Definition of Terms**

The E16x356 protection system incorporates one testgenerator of type E1698 and three modules of type E1668 for evaluation of speed signals and external trip signals. These modules are named "Monitors".

The logic blocks of the Monitors for the evaluation of the external trip signals are named "Voter". Each of the monitors represents a "Channel" (A, B and C) for processing of the speed signals and external trip signals.

The logic results of the three Channels are connected internally via the trip relays to form six 2oo3 trip circuits, whereof the circuits I, II and III are referred to as "Trip Lines". The three Trip Lines of the E16x356 system are used to switch-off of valves or other drives respective to actuate a "2oo3 solenoid valve block".

The trip state of the E16x356 system may be locked. This function is referred to as "Trip Lock"

Trip is initiated if:

- 2oo3 Monitors detect overspeed condition
- 2oo3 speed sensors are detected as faulty by Monitors
- 2oo3 Monitors detect external trip condition via Voters (1oo2, 2oo2, 2oo3 or 3oo3 selectable)

## 1.4 Key Features of System E16x356

Trip initiation function is SIL3/IEC61508 and DIN EN ISO 13849:2008 Cat.3 PLe compliant as stand alone unit (without external testing by PLC or by DCS or by operator).

**Total response time from trip event to de-energize the Trip Lines:  
less than 15 milliseconds.**

**Test Interval = 20 Years (no periodic maintenance required).**

**Maximum safety at maximum availability by:**

- TMR (Triple Modular Redundancy) with three Monitors E1668
- Triple speed measurement and evaluation by each Monitor
- Variable overspeed alarm depending on acceleration
- Monitoring versus speed low limit to protect against incorrect mounting or malfunction of speed sensors
- Permanent monitoring of speed sensors
- Evaluation of external trip-condition signals by Voters in each Monitor. Response to signals selectable for each Voter individually (logic function, low/high: trip, response time)
- Monitoring of Monitors by Testgenerator
- Permanent monitoring of feedback signals from a 2oo3 solenoid valve block by the test generator with cyclical, fully automatic or externally controllable tests
- Permanent monitoring of the status of the trip lines by the test generator and cyclical, fully automatic testing of the reaction to triggering of the trip lines using feedback signals from a 2oo3 solenoid valve block. This block can also be manually excited via the keyboard located on the front of the test generator or with an external signal
- Each Trip Line (trip circuit) in 2oo3 technique
- Trip Lines I, II, III, IV, V, VI are formed by safety relays with force guided contact sets
- Trip Line monitoring with Trip Lock function (selectable)•

**Additional features of the E16x356 system:**

- Overlapping tests by DCS are possible
- Display in each module for measured values and diagnostics
- Alarm outputs via opto relays or PROFIBUS to DCS
- Free extra alarm from each Monitor
- Up to 6 speed setpoints with 2oo3 logic outputs (if Voters are not required)
- Sensor signal repeater outputs, free floating and push/pull
- Optional analog output (to represent the speed) 0/4..20 mA for each Monitor
- Rotation direction alarm (only with sensors type A5S with rotating direction output)
- Parameters may be set by front keys (protected by code digit) or by RS232 interface (password protected)
- Redundant PROFIBUS interface to DCS

E16x356.abc

**c = 1** : Speed Signal Inputs and power supply for BRAUN A5S sensors  
**c = 2** : Speed Signal Inputs and power supply for Eddy Current Sensors  
**c = 3** : Speed Signal Inputs for MPU (magnetic pick up)

**b = 1** : 1 Voter in each Monitor for external trip release condition  
**b = 2** : 6 Voters in each Monitor for external trip release conditions

**a = 0** : without Analog Output (to represent the speed)  
**a = 1** : 1 Analog Output in each Monitor A, B, C  
**a = 2** : 1 Analog Output rated SIL3 in each Monitor A, B, C

**x = A** : Surface Mount Version

**x = E** : 19-Inch Rack File

**x = G** : Nema 4 Version with front window (surface mount)

## **1.6 Certifications**

### **1.6.1 Certification IEC61508; SIL3**

The E16x356 system is certified by TÜV to be compliant with IEC61508; SIL3 as a stand alone TMR Trip-System for the functions:

- Overspeed Protection
- Voters for external Trip Release Conditions, such as emergency stop, boiler protection etc.
- Analog Output (for actual speed value)
- 2oo3 Trip Outputs

### **1.6.2 Certification DIN EN ISO 13849-1:2008; Cat.3 PLe**

The E16x356 system is certified by TÜV to be compliant with DIN EN ISO 13849:2008; Cat.3 PLe as a stand alone TMR Trip-System for the functions:

- Overspeed Protection
- Voters for external Trip Release Conditions, such as emergency stop, boiler protection etc.
- Analog Output (for actual speed value)
- 2oo3 Trip Outputs



# Certificate

No. SEBS-A.144312/12, V4.1

TÜV NORD Systems GmbH & Co. KG hereby certifies to

## Braun GmbH Industrie-Elektronik

Esslinger Straße 26  
71334 Waiblingen-Hegnach  
Germany

that the protection system

## E16x3xx.abc

is capable for safety related applications and meets the requirements listed in the below mentioned standards.

- IEC 61508-1 / -2 / -3:2010, SIL 3
- DIN EN ISO 13849-1:2023, PL e, Cat. 3
- DIN EN ISO 13849-2:2013, PL e, Cat. 3

Certification program Leittechnik (SEB-ZE-SEECERT-VA-320-20, Rev. 6 / 04.24)

The protection system E16x3xx.abc can be used in safety related applications according to IEC 62061:2021, SIL 3

The certification is based on the report No. SEBS-A.144312/12TB and the tracking list in the respective valid version.

This certificate entitles the usage of the adjacent conformity mark.

Valid until: 2030-05-19  
Reference: 8123599299

Hamburg, 2025-05-19

**TÜVNORD**

Digitally signed by  
Nelke Tobias  
Date: 2025.07.02  
11:29:30 +02'00'

**Tobias Nelke**  
(Techn. Head of certification body)

Certification Body SEECERT  
TÜV NORD Systems GmbH & Co. KG  
Große Bahnstraße 31, 22525 Hamburg, Germany



## 1.7 Safety Data

The safety characteristics apply to the functions:

- Overspeed Protection
- Voters for external Trip Release Conditions, such as emergency stop, boiler protection etc.
- Analog Output (for actual speed value)
- Valve Control Circuits

**Note:**

The failure rate of the sensors are not part of the overall failure rate.

### 1.7.1 Safety Data IEC61508; SIL3

System type B; HFT = 1; architecture 2oo3,

Useful lifetime = 20 years

Proof Test Interval (T1) = 20 years

**SFF = 96,7%**

**PFDavg =  $8,41 \cdot 10^{-6}$  at MTTR = 72 h**

**PFDavg =  $9,67 \cdot 10^{-6}$  at MTTR = 168 h**

**PFDavg =  $1,85 \cdot 10^{-5}$  at MTTR = 1 month**

**PFDavg =  $1,24 \cdot 10^{-4}$  at MTTR = 1 year**

### 1.7.2 Safety Data DIN EN ISO 13849-1:2008; Cat.3 PLe

System type B; HFT = 1; architecture 2oo3, service time 20 years

**MTTFd = 489,5 years**

**DCavg = 93,18%**

**CCF = 80**

## 2 System Structure and I/Os

### 2.1 System Structure

The structure of the system is shown in chapter **2.1.4** (figures 2, 3, 4 and 5).  
The wiring of the system is shown in chapter **2.1.5** (figures 6, 7, 8, 9 and 10).  
The indexes "see 2.x.x" in these figures refer to the corresponding chapters 2.x.x. which describe the according functions.

#### 2.1.1 Speed Sensors

With versions E16x356.xx1:

Three A5S differential Hall effect sensors, with integrated signal amplifier are placed at the machine shaft.

The differential Hall effect sensors A5S are not susceptible to uniform external magnetic fields. Air gap variations between machine and sensor do not create false signals.

With versions E16x356.xx2:

Three speed signals from eddy current sensors or MPU sensors are evaluated.

#### 2.1.2 System Components

The system comprises one Testgenerator E1698 and three Monitors E1668.  
The Testgenerator E1698 checks and validates the performance of the Monitors, of the Trip Lines and of an external 2oo3 solenoid valve block by tests.

The Monitors E1668 monitor the sensors, the speed and the external trip conditions.

Trip is initiated by de-energizing of the Trip Lines if:

- 2oo3 Monitors detect overspeed condition
- 2oo3 speed sensors are detected as faulty by Monitors
- 2oo3 Monitors detect external trip condition via Voters (1oo2, 2oo2, 2oo3 or 3oo3 selectable)

The Monitors and the Testgenerator are interconnected via the rack backplane. The rack backplane does not contain any active components.

#### 2.1.3 System Design

The system is designed for bulkhead mounting or available as 19" rackmount 3HE/84TE.

## 2.1.4 System Structure Diagrams

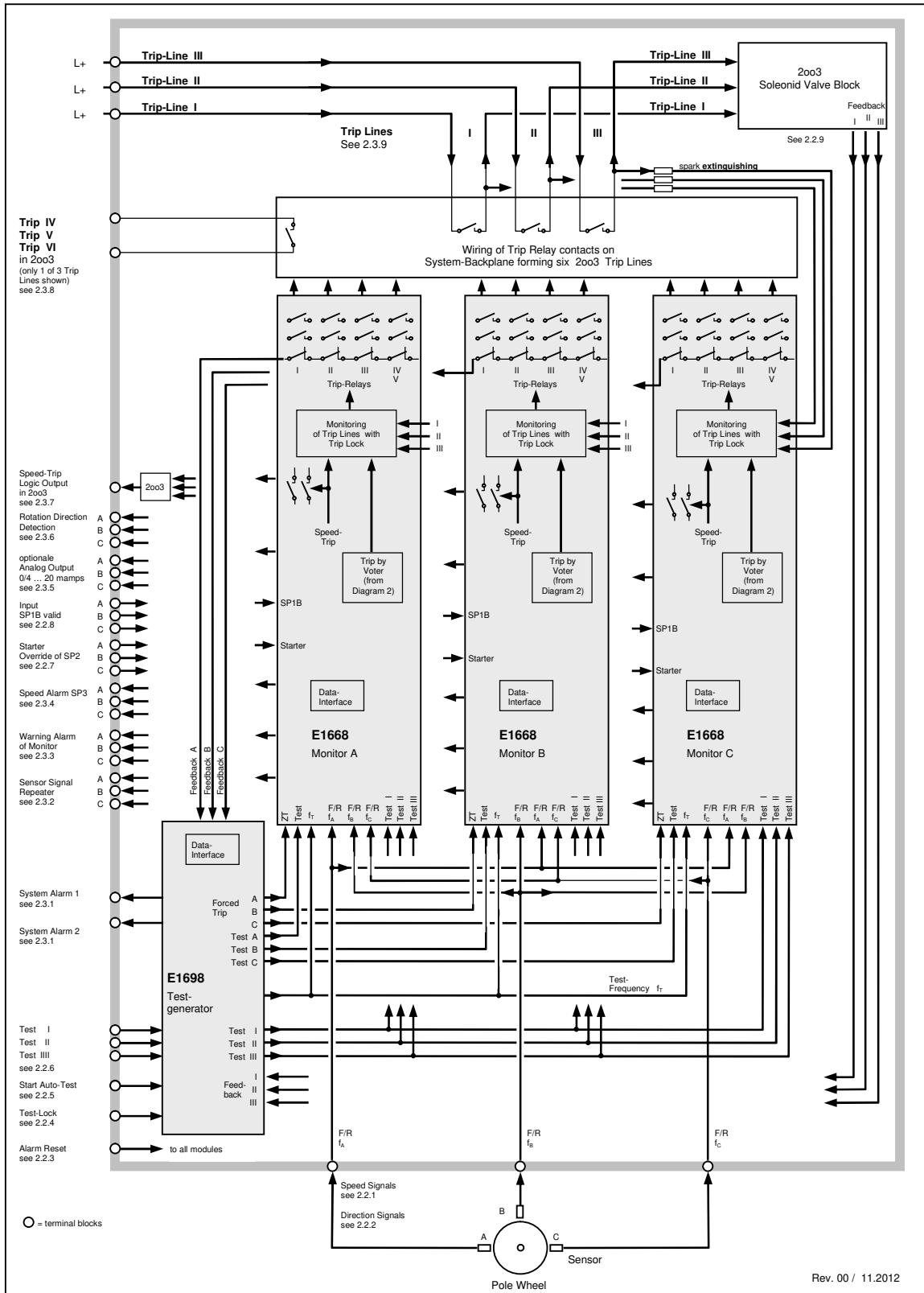

Figure 2: E16x356 System Structure Diagram 1 of 2 : Testgenerator and speed section of Monitors

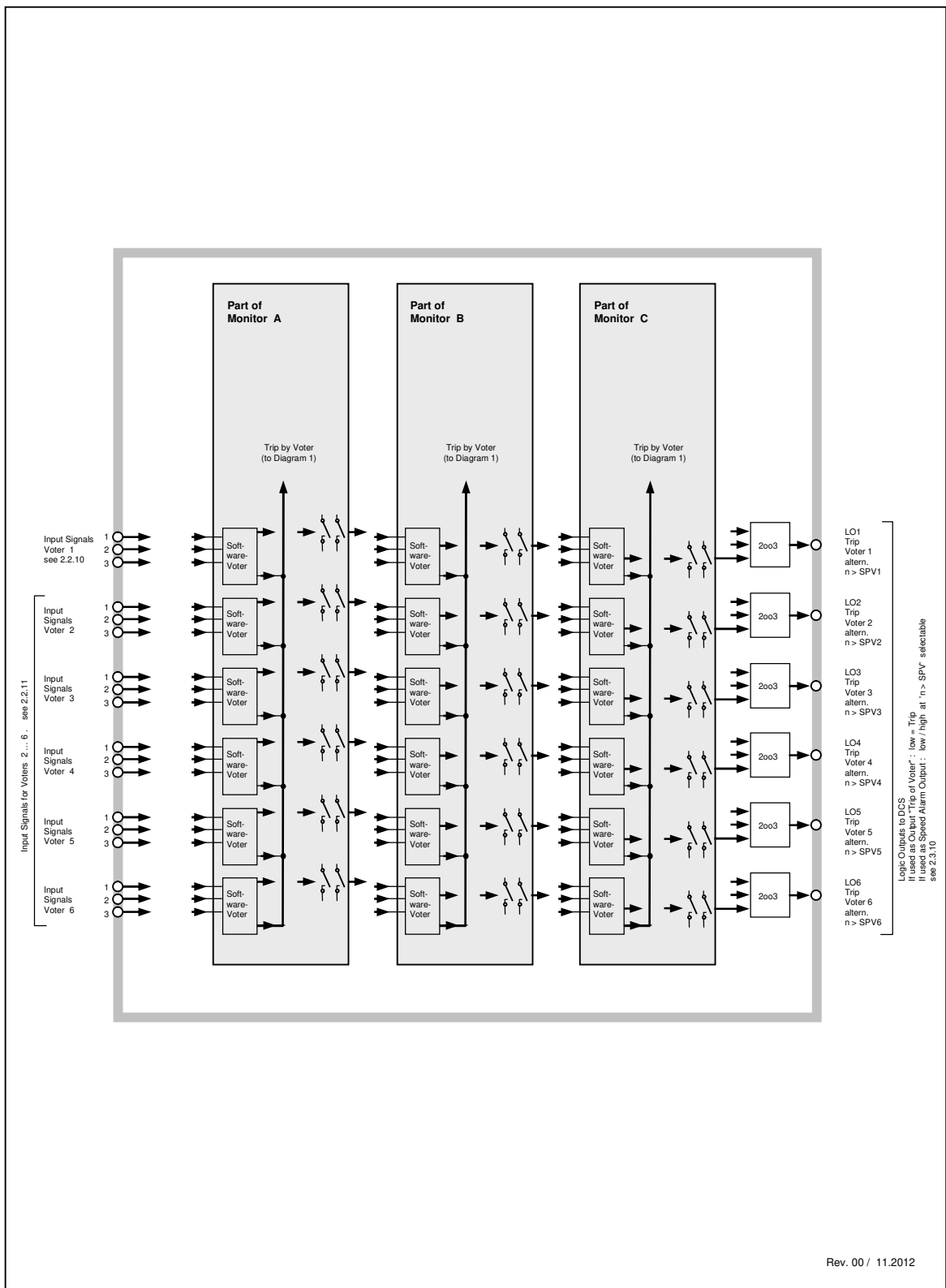

Figure 3: E16x356 System Structure Diagram 2 of 2 : Voter section of Monitors

## 2.1.5 System Wiring Diagrams

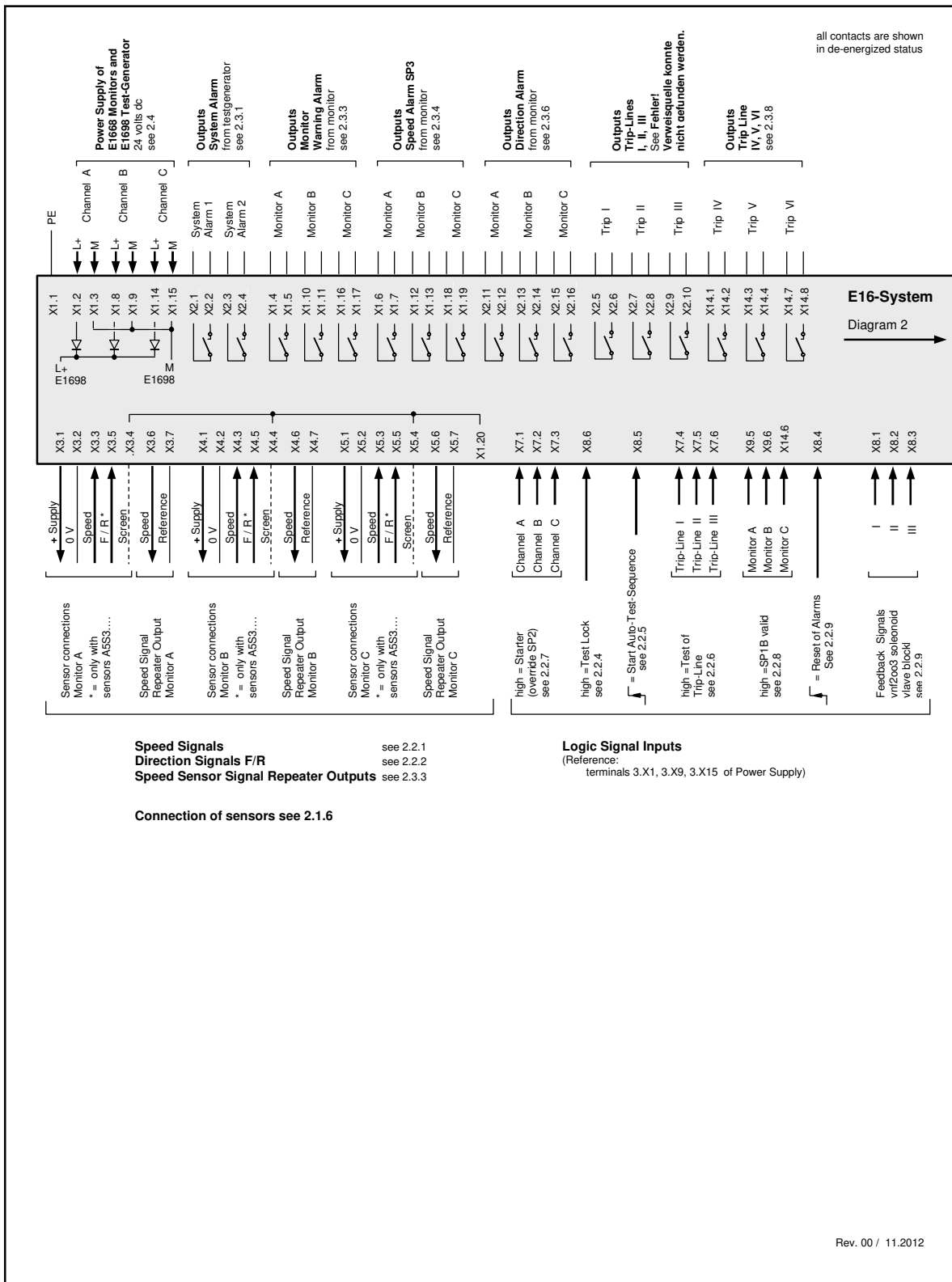
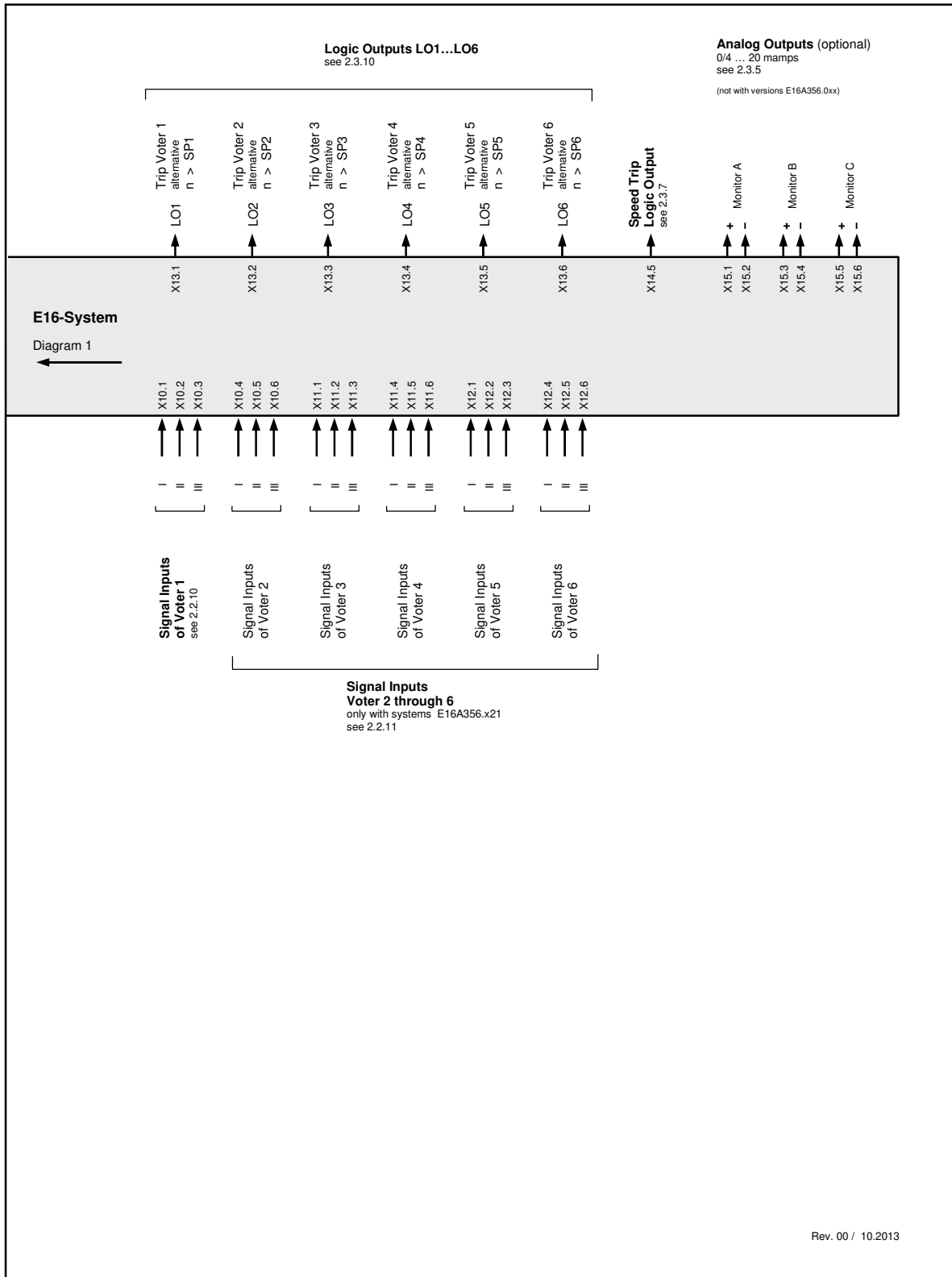

Figure 4: E16x356 System Wiring Diagram 1 of 3 : Testgenerator and speed section of Monitors



Rev. 00 / 10.2013

Figure 5: E16x356 System Wiring Diagram 2 of 3 : Voter section of Monitors

## 2.1.6 Connection of Sensors to the Speed Signal Inputs

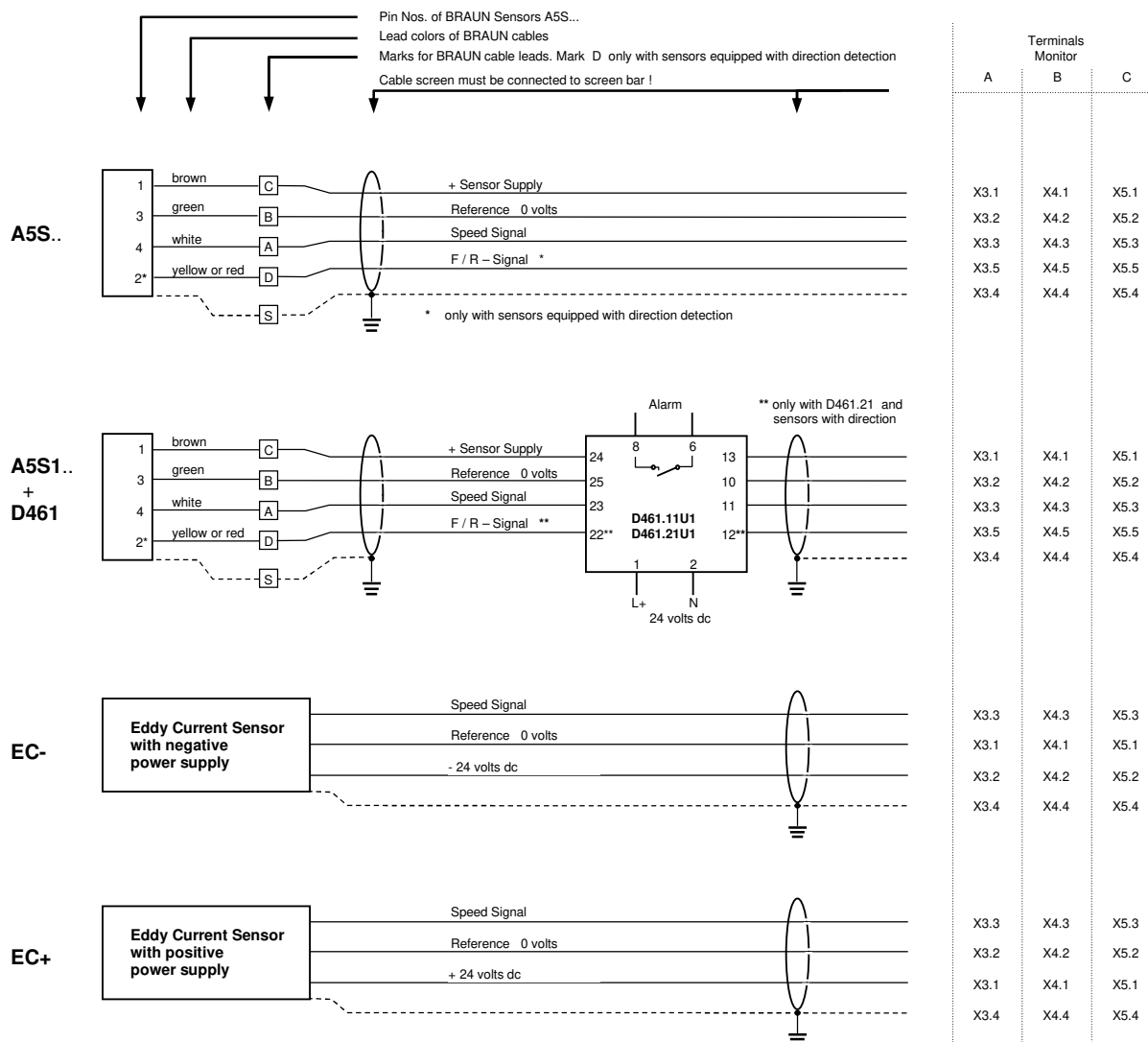

Rev. 00 / 02.2012

Figure 6: E16x356 System Wiring Diagram 3 of 3 : Connection of speed sensors

## **2.2 Inputs of the System**

### **2.2.1 Speed Signal**

The speed signals are internally wired to all three Monitors in parallel.

With versions E16x356.xx1:

The speed signal inputs match the values of sensors A5S...

The speed signal inputs are rated SIL3/IEC61508 if sensors of type A5S... (also via barriers D461) are connected. For other sensors this is only valid, if the sensor supplier guarantees, that the sensors will not give erratic speed signals due to a common cause failure. The instructions of the sensor supplier must be observed.

Technical data of inputs see 3.1.1.1.

With versions E16x356.xx2:

The signal inputs match the values of eddy current sensors or of MPUs.

The speed signal inputs are rated SIL3/IEC61508, if the sensor supplier guarantees, that the sensors will not give erratic speed signals due to a common cause failure. The instructions of the sensor supplier must be observed.

Technical data of inputs see 3.1.1.2.

### **2.2.2 Rotation Direction Signal (F/R: Forward/Reverse)**

The rotating direction signal inputs match the values of BRAUN sensors A5S with rotating direction signal.

The rotating direction signals are internally wired to all three Monitors in parallel.

The rotating direction signal inputs are rated SIL3/IEC61508 (valid only for sensors A5S3..).

Technical data of inputs see 3.1.2.

### **2.2.3 Reset of Alarms**

The Reset signal is internally connected to all modules in parallel. It resets a no longer prevailing, but latched alarm or trip condition.

A signal transition from low to high will reset a latched alarm.

Minimum time of reset signal: 0.5 s to ensure correct reset of all modules.

The input Reset of Alarms is rated SIL3/IEC61508 provided that the signal source is rated SIL3/IEC61508.

Technical data of input see 3.1.3.

### **2.2.4 Test Lock**

A high signal will abort any running system inherent cyclic proof test and inhibit further tests as long as the signal is high. If the signal is true for more than 60 minutes, the alarms System Alarm 1 and System Alarm 2 are initiated.

The input Test Lock is rated SIL3/IEC61508 provided that the signal source is rated SIL3/IEC61508.

Technical data of input see 3.1.3.

### **2.2.5 Start Auto Test Sequence**

A signal transition from low to high will start an automatic test sequence. First the test (if selected, see step P03.01 of E1698) of the Trip Lines for the Valve Control Modules is performed, two minutes later the test of the Monitors is performed.

The input Start Auto Test Sequence is rated SIL3/IEC61508 provided that the signal source is rated SIL3/IEC61508.

Technical data of input see 3.1.3.

## **2.2.6 Test I, Test II, Test III**

The inputs Test I, II, III are enabled, if the Testgenerator E1698 is programmed to external Trip Line Test (see parameter P03.01 of E1698).

If the input is high, the corresponding Trip Line will switch to trip condition.

The inputs may be configured to inhibit simultaneous test of two or three Trip Lines.

The input Test I, II, III are rated SIL3/IEC61508 provided that the signal source is rated SIL3/IEC61508.

Technical data of inputs see 3.1.3.

## **2.2.7 Starter (Override of SP2)**

Each Monitor has one input for the starter condition. As long as the input is high, the starter condition is true.

During starter condition the monitoring versus a speed low limit (SP2) is disabled.

The inputs Starter are rated SIL3/IEC61508 provided that the signal source is rated SIL3/IEC61508.

Technical data of inputs see 3.1.10.

## **2.2.8 SP1B Valid**

Each Monitor has one input to select SP1B as trip setpoint.

As long as the input is high, setpoint value SP1B (see step P03.03 of E1668) is true.

With open input (low), setpoint value SP1A (see P03.00 of E1668) is true.

The inputs SP1B Valid are rated SIL3/IEC61508 provided that the signal source is rated SIL3/IEC61508.

Technical data of inputs see 3.1.3.

## **2.2.9 Feedback inputs of the 2oo3 solenoid valve block**

The feedback inputs are connected on the E1698 test generator.

The inputs are only monitored when the "Automatic trip line test" is activated (see Step P03.01 of E1697).

The active level (High or Low as trip criterion) can be selected in Step P03.03 of E1697.

The "Feedback of 2oo3 solenoid valve block" inputs are SIL2/IEC61508 compliant (under the condition that the signal source is SIL2/IEC61508 compliant).

See 3.1.3 for the technical data of the inputs.

## **2.2.10 External Signals for Voter 1**

The input signals for Voter 1 are internally connected to all Monitors in parallel.

The input load of Voter 1 meets the requirements for the redundant outputs of a failsafe PLC (load > 45 mA per input).

The signal truth level (high or low as trip condition), the voting principle (1oo2, 2oo2, 2oo3, 3oo3) and the response time is selectable. Configuration of the Voter is done in steps P10.xx of E1668.

The inputs Voter 1 are rated SIL3/IEC61508 provided that the signal source is rated SIL3/IEC61508.

Technical data of inputs see 3.1.4.

## **2.2.11 External Signals for Voters 2 ... 6**

The input signals for Voters 2 ... 6 are internally connected to all Monitors in parallel.

The signal truth level (high or low as a trip condition), the voting principle (1oo2, 2oo2, 2oo3, 3oo3) and the response time is selectable for each Voter individually. Configuration of Voters is done in steps P11.xx to P15.xx of E1668.

The inputs Voter 2...6 are rated SIL3/IEC61508 provided that the signal source is rated SIL3/IEC61508.

Technical data of inputs see 3.1.3.

**Note:**

Systems E16x356.x1x do not have inputs for Voters 2... 6.

## 2.3 Outputs of the System

### 2.3.1 System Warning Alarm 1 and System Warning Alarm 2

The alarms System Warning Alarm 1 and System Warning Alarm 2 from Testgenerator E1698 are initiated if at least one of the following conditions is true:

- a Monitor does not show correct response or
- a Monitor issues a Sensor Fault alarm or
- the feedback signals from the Valve Control Modules do not show correct response (if monitored) or
- a Monitor issues Antivalence fault alarm of Voter inputs

**Note:**

If the alarms System Alarm 1 and System Alarm 2 do not have the same status, the Testgenerator E1698 itself has a malfunction.

The outputs System Alarm 1 and System Alarm 2 are rated SIL3/IEC61508.

Technical data of outputs see 3.2.3.

### 2.3.2 Speed Signal Repeater

Each Monitor repeats the speed signal of its main sensor (Monitor A repeats sensor signal A) to the periphery at a non-reactive pulse signal output.

The Speed Signal Repeater Outputs are rated SIL2/IEC61508.

Technical data of outputs see 3.2.1.

### 2.3.3 Monitor Warning Alarm

The Monitor warning alarm (for each Monitor individually) is initiated if at least one of the following conditions is true:

- Monitor initiates trip (due to overspeed or Voter), if selected in step P02.11 of E1668
- Deviation of its own sensors versus both sensors of neighbor Monitors, if monitored selection in steps P02.07 through P02.09 of E1668.
- Measured speed lower than SP2 (after starter condition), if monitored selection in step P02.06 of E1668
- Sensor circuit fault, if monitored selections in steps P02.04 and P02.05 of E1668
- If starter condition is still true and speed exceeds 50% of nominal speed (as set in step P01.03), if selected in step P02.0)

**Note:**

The Monitor Warning Alarm is not initiated, if the Monitor detects antivalence at its Voter inputs. This status is forwarded to the Testgenerator E1698 which then initiates the alarms System Alarm 1 and System Alarm 2. In case of alarm chapter "Troubleshooting " of the manual must be consulted.

The outputs Monitor Warning Alarm are rated SIL2/IEC61508.

Technical data of outputs see 3.2.3.

### 2.3.4 Speed Alarm SP3

Each Monitor has a free adjustable speed alarm output SP3.  
Configuration of SP3 in steps P05.xx of E1668.  
The outputs Speed Alarm SP3 are rated SIL2/IEC61508.  
Technical data of outputs see 3.2.3.

### 2.3.5 Analog Outputs proportional to measured speed (Option)

The (optional) analog outputs have a range of 0/4 .. 20 mA.  
Configuration of the analog output in steps P08.xx of E1668.  
The analog outputs of versions E16x356.1xx are rated SIL2/IEC61508.  
The analog outputs of versions E16x356.2xx are rated SIL3/IEC61508.  
Technical data of outputs see 3.2.2.

### 2.3.6 Rotation Direction Detection

If operated with sensors A5S with rotating direction signal, the sense of direction is signaled.  
Each Monitor votes the rotating direction input signals 2oo3. Each Monitor has a rotating direction detection output.  
The outputs Rotating Direction Detection are rated SIL2/IEC61508.  
Technical data of outputs see 3.2.3.

### 2.3.7 Speed Trip Logic Output (2oo3 voted)

Speed trip logic output is actuated, if minimum 2 of the 3 Monitors detect overspeed condition. If overspeed status is latched, the alarm will persist until reset (see 5.2.2).  
Output high : no overspeed trip  
Output low : overspeed trip  
The Speed Trip Logic Output is rated SIL2/IEC61508.  
Technical data of output see 3.2.4.

### 2.3.8 Trip Lines IV, V, VI

The Trip Lines IV, V, VI are 2oo3 circuits formed by contacts of safety trip relays IV and V of Monitors A, B, C.  
Trip is initiated if minimum two Monitors E1668 are in trip status.  
Trip Lines IV, V, VI are intended to signalize the trip to a DCS or PLC.  
The outputs of Trip Lines IV, V, VI are rated SIL3/IEC61508.  
Technical data of output see 3.2.5.

### 2.3.9 Trip Lines I, II, III

The Trip Lines I, II, III are 2oo3 circuits formed by contacts of safety trip relays I or II or III of Monitors A, B and C.  
Trip is initiated if minimum two Monitors E1667 are in trip status.  
Trip Lines I, II, III are, for example, provided for operating a 2oo3 solenoid valve block.  
The outputs of Trip Lines I, II, III are rated SIL3/IEC61508.  
Technical data of output see 3.2.6.

### 2.3.10 Logic Outputs LO1 through LO6 (voted 2oo3)

The Logic Outputs LO may be assigned to signalize a Voter trip or to a speed alarm.  
If assigned to Voter trip Ausgang High: output high : no trip of Voter  
output low : trip of Voter  
If assigned to speed alarm: output high/low if n > SP is selectable.  
The Logic Outputs LO1 through LO6 are rated SIL2/IEC61508.  
Technical data of outputs see 3.2.4.

## **2.4 Power Supply**

### **2.4.1 Power Supply of Monitors E1668 and Testgenerator E1698**

The L+ supply of the Testgenerator is formed by an internal power rail by the three Monitor L+ supplies (decoupled by diodes).

The M supply of the Testgenerator is formed by an internal power rail by the three Monitor M supplies.

Technical data see 3.3.1.

## **2.5 Data Interface**

Each of the Monitors E1668 and the Testgenerator E1698 have two female 9pole Sub-D connectors on the front side. On the left connector are a PROFIBUS interface (with standard pinning) and a RS232 interface (non standard pinning) implemented. On the right connector is a PROFIBUS interface with identical function as on the left connector implemented.

### **2.5.1 PROFIBUS Interface for Status and Diagnostics of the System**

The PROFIBUS interface reflects the standard PROFIBUS DP and serves for the upload of status and diagnostic information of the system to a PLC or DCS.

### **2.5.2 RS232 Interface for Setting of Parameters**

The RS232 interface in conjunction with the interface software IS-RS232-E16 serves to download parameter values from a PC to the E16 and to upload parameter values from the E16 to a PC. The data communication in between the E16 and the PC fulfills SIL3/IEC61508 requirements.

## **3 Technical Specifications**

### **3.1 Technical Data of Inputs**

#### **3.1.1 Technical Data of Speed Signal Inputs**

##### **3.1.1.1 Hall Sensor Inputs**

Maximum input frequency : 30 kHz  
Maximum signal voltage : 30 Vdc  
Input low : at < 3 Vdc  
Input high : at > 7 Vdc  
Impedance : approx. 5 kOhm  
Minimum pulse high time: 20 microseconds  
Minimum pulse low time: 20 microseconds  
Sensor supply : approx. 13 Vdc, maximum 80 mA (for versions E16x356.xx1)  
The speed signal inputs have the same reference potential but are free floating versus all other circuits. The sensors are supplied by internal isolated power sources of the Monitors.

##### **3.1.1.2 Eddy Current Sensor Inputs or MPU (Magnetic Pickup) Inputs**

Maximum input frequency : 30 kHz  
Maximum signal voltage : 30 Vpp  
Trigger hysteresis : 0.07 to 2.5 Vpp (ac-coupled input)  
Impedance : approx. 47 kOhm  
Sensor supply : approx. 24 V, maximum 120 mA (for versions E16x356.xx2)  
The speed signal inputs have the same reference potential but are free floating versus all other circuits. The sensors are supplied by internal isolated power sources of the Monitors.

#### **3.1.2 Technical Data of Rotation Direction Inputs**

Maximum signal Voltage : 30 Vpp  
Input low : at < 3 Vdc  
Input high : at > 7 Vdc  
Impedance : approx. 22 kOhm  
Same reference potential as speed signal inputs.

#### **3.1.3 Technical Data of Binary Inputs (excluding Voter 1)**

Input high : 18..48 Vdc (nominal current at 24 Vdc: 6 mA)  
Input low : at < 3 Vdc or open input  
Reference potential : M (negative pole of Monitor power supply)

#### **3.1.4 Technical Data of Binary Inputs of Voter 1**

Input high : 18..33 Vdc (nominal current at 24 Vdc: 45 mA)  
Input low : at < 3 Vdc or open input  
Reference potential : M (negative pole of Monitor power supply)

#### **3.1.5 Chapter left blank intentionally**

#### **3.1.6 Chapter left blank intentionally**

#### **3.1.7 Chapter left blank intentionally**

### **3.1.8 Chapter left blank intentionally**

### **3.1.9 Chapter left blank intentionally**

### **3.1.10 Technical Data of Inputs Starter**

Input high : 18..33 Vdc (nominal current at 24 Vdc: min. 11mA, max. 19mA)

Input low : at < 3 Vdc or open input

Reference potential : M (negative pole of Monitor power supply)

## 3.2 Technical Data of Outputs

### 3.2.1 Technical Data of Speed Sensor Signal Repeater Outputs

High level : > 20 V with max. load, (maximum 26 V without load)  
Low level : < 2 V, with max. load  
Maximum load: 1 kOhm  
The outputs are short-circuit proof and free floating (also versus each other).  
The outputs are supplied by internal isolated power sources of the Monitors.

### 3.2.2 Technical Data of Analog Outputs

Range : 0/4...20 mA  
Resolution : 12 Bit  
Maximum load : versions E16x356.1xx : 650 Ohm, versions E16x356.2xx : 400 Ohm  
Linearity error : < 0.1%  
Temperature stability :  $\pm 0,02$  %/°C within a range of 0...60°C.  
The outputs are short-circuit proof and free floating (also versus each other).  
The outputs are supplied by internal isolated power sources of the Monitors.

### 3.2.3 Technical Data of Opto Relay Outputs

Maximum rating : 50 Vdc / 50 mA.  
The outputs are passive without polarity restrictions (comparable to dry-contact characteristic), short-circuit proof and free floating (also versus each other). They must be supplied externally).  
**Note:**  
In case of temporary overload these outputs switch to a latched tri state characteristic until the source signal changes to low state or the output supply voltage has been switched off and on.

### 3.2.4 Technical Data of Logic Outputs

The outputs are fed from the system power supply.  
Reference potential: M (negative pole of Monitor power supply).  
High level : Power supply L+ minus 2 V  
Low level : < 3 Vdc  
Maximum output current : 50 mA  
The outputs are short-circuit proof  
**Note:**  
In case of temporary overload these outputs switch to a latched tri state characteristic until the source signal changes to low state or the Monitor supply voltage has been switched off and on.

### 3.2.5 Technical Data of Trip Lines IV, V, VI

Maximum rating : 50 Vdc / 300 mA.  
The outputs are passive of dry-contact type, short-circuit proof and free floating. They must be supplied externally.  
Maximum voltage drop at a load equal to 300 mA is < 1 V.  
**Note:**  
In case of short-circuit the output goes low as long as the short-circuit persists.

### 3.2.6 Technical Data of Trip Lines I, II, III

Maximum load: 50 VDC/3 A/75 W  
Maximum load for DC13 applications: 24 V/3 A  
Outputs are not short-circuit-proof (continuous currents greater than 8 A will destroy the outputs).  
Recommended back-up fuse: 3 A rated current with max. 6 A release current

Impedance: 10 kohms connected to L- (negative terminal of power supply)  
External spark quenching measures must be provided for inductive loads!

Reaction time from "overspeed" or "External trip via voter" event until switch-off of the trip lines:  
< 15 milliseconds.

### 3.3 Technical Data of Power Supplies

#### 3.3.1 Technical Data of Power Supply of Monitors E1668 and Testgenerator E1698

3x 24 Vdc (18...33 Vdc) from a power supply with protective separation (SELV or PELV), conforming to IEC 61131-2 requirements.

Maximum current consumption : < 300 mA per Monitor supply

Maximum power loss: < 20 W

Recommended primary fuse rating for Monitor supply : max. 1 A nominal with max. 2 A actuation current.

#### 3.4 Amount of Heat to be dissipated

Maximum heat to be dissipated of a main rack equipped with 1 module E1698 and 3 modules E1668 is equivalent to a power loss < 20 W.

#### 3.5 Installation Conditions

Ambient temperature in operation : 0 °C..+55 °C

Ambient temperature in storage : -20 °C..+85 °C

Relative humidity: < 80 %, non-condensing

To be installed in dry cabinets in air-conditioned rooms

#### 3.6 Protection Grade

Insulation class III

IP20

#### 3.7 Connectors

##### 3.7.1 Connectors with Pull Spring Terminals

Type Phoenix Combicon FK-MLP1.5 or DFMC1.5  
fitting for:

Conductor cross section solid min.:	0.2 mm <sup>2</sup>	
Conductor cross section solid max.:	1.5 mm <sup>2</sup>	
Conductor cross section stranded min.:	0.2 mm <sup>2</sup>	
Conductor cross section stranded max.:	1.5 mm <sup>2</sup>	
Conductor cross section stranded, with ferrule without plastic sleeve min.:		0.25 mm <sup>2</sup>
Conductor cross section stranded, with ferrule without plastic sleeve max.:		1.5 mm <sup>2</sup>
Conductor cross section stranded, with ferrule with plastic sleeve min.:		0.25 mm <sup>2</sup>
Conductor cross section stranded, with ferrule with plastic sleeve max.:		0.75 mm <sup>2</sup>
Conductor cross section acc. to AWG/kcmil min.:	No. 24	
Conductor cross section acc. to AWG/kcmil max.:	No. 16	
Minimum AWG according to UL/CUL:	28	
Maximum AWG according to UL/CUL:	16	

Stripping length : 10 mm

### 3.7.2 Chapter left blank intentionally

### 3.8 Conformity to Standards

2006/42/EC  
SIL3/IEC61508:2010, DIN EN ISO 13849-1:2008 Cat 3 PL e, API 612, API 670,  
2014/35/EU, IEC 61010-1,  
2014/30/EU, IEC 61000-6-4, IEC 61326-3-2

### 3.9 Useful Lifetime, Proof Test Interval and Maintenance of the E16x356 System

The assumed useful lifetime of the E16x356 system is 20 years.  
The proof test interval of the E16x356 system is 20 years.  
Therefore the system is maintenance free and does not require service until a fault occurs.

#### **Attention !**

Any faulty module must be replaced with a new one within a time period of maximum 1 year.  
Instructions for replacement procedure see manual of E16x356.  
It is recommended to return defective hardware to BRAUN for inspection and repair if possible.  
Repairs not executed by BRAUN are not admissible and will render void the SIL3 level.

3.10

Dimensions of System E16A356

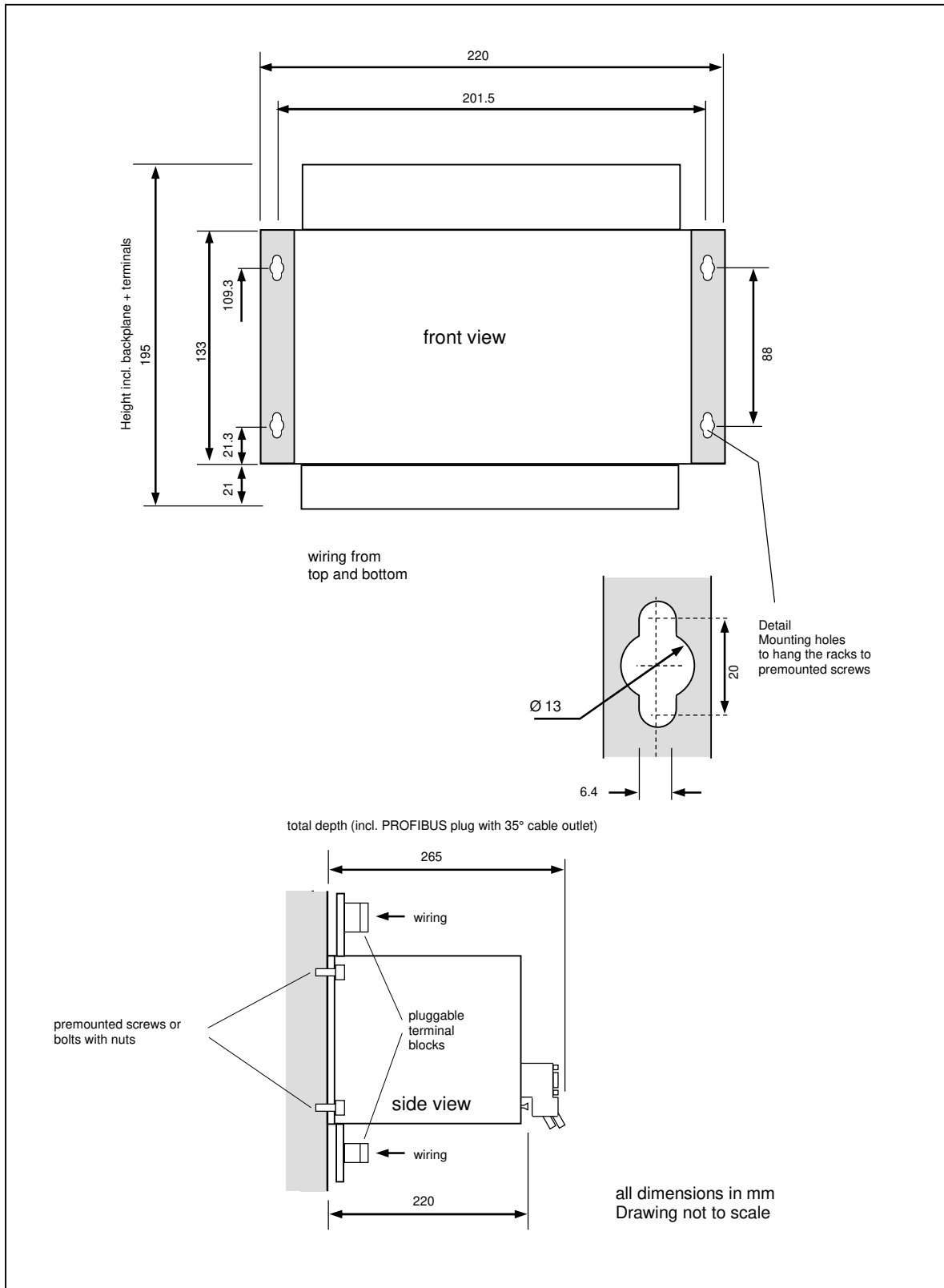

Figure 7: Dimensions of System E16A356

3.11

Dimensions of System E16E356

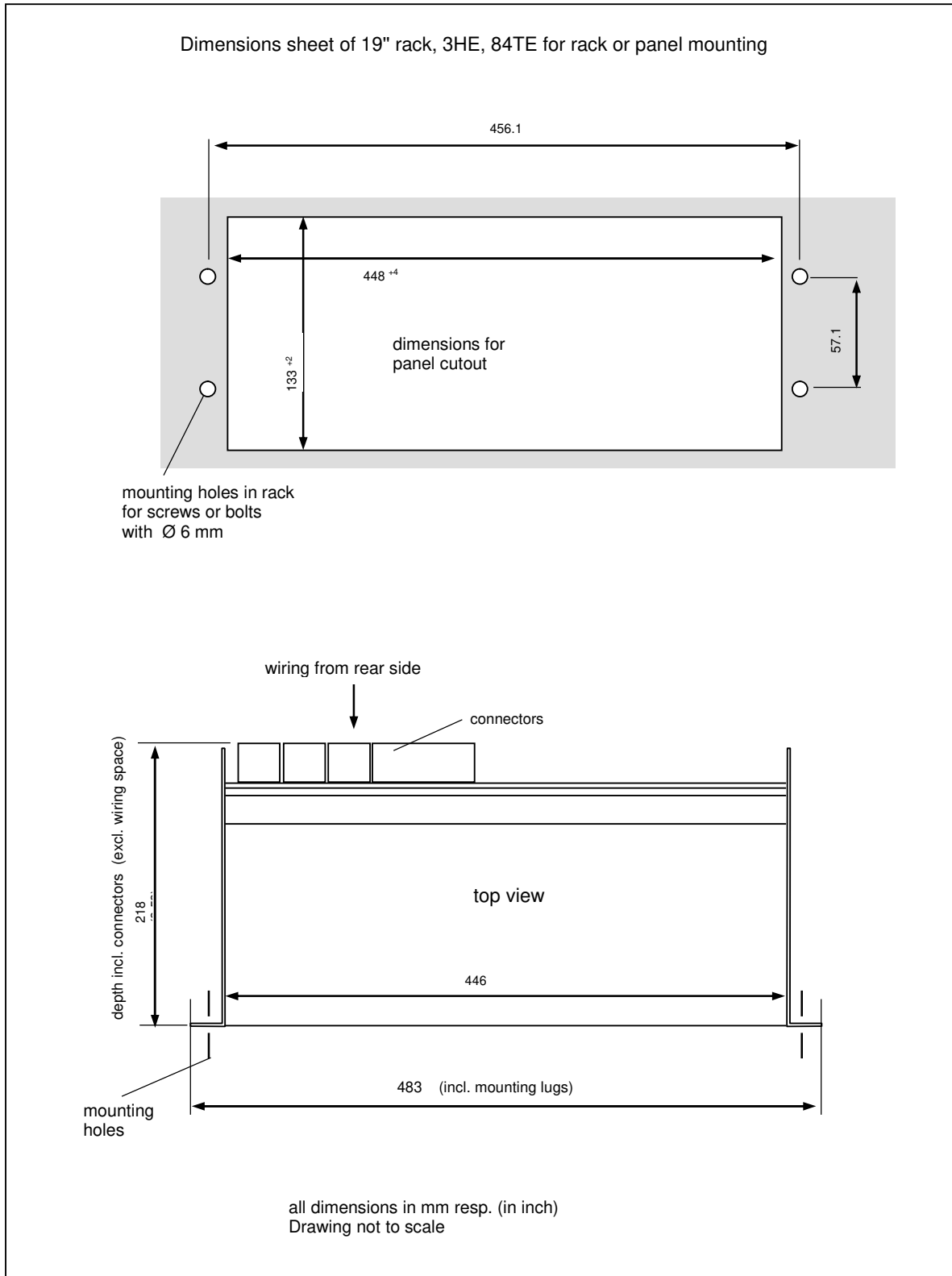

Figure 8: Dimensions of System E16E356

### **3.12 Chapter left blank intentionally**

Figure 9: Left blank intentionally

### **3.13 Weight of E16x356**

E16A356 : 3,0 kg  
E16E356 : 3,7 kg

### **3.14 Material specifications of E16A356 or E16E356**

Housing: Aluminium  
Front panels and back panel: Lexan or. FR4 (min. V-1 by UL)

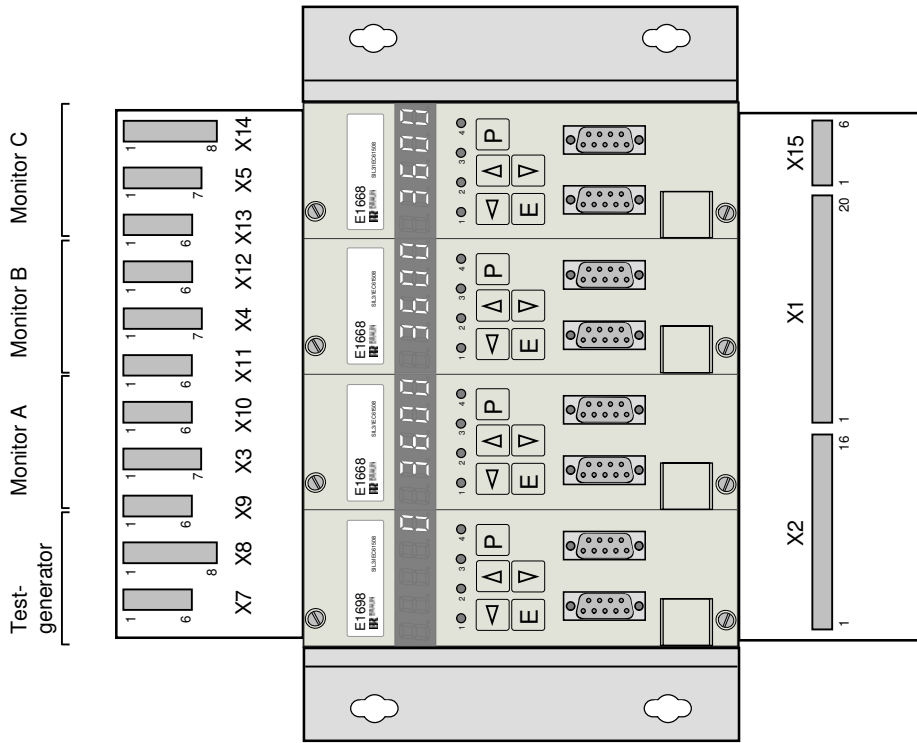

Figure 10: Total Front View with Location of Terminals

## **4 Safety Notes for Installation and Operation**

### **4.1 Safety Notes for Installation**

This unit has been designed and inspected according to standards DIN EN 61010-1 (VDE 0411-1). Observe these instructions and wiring diagrams carefully, to ensure this protection. The installation must be done only by adequately qualified personnel.

#### **4.1.1 General Instructions**

Specifically, connect the PE terminal 1.X1 to a safe ground potential.

Do not open the instrument. Connections and all programming are done from outside. When removing it from its enclosure however, from whatever reason, make sure that power is switched off.

The instrument may be installed in any position, but not in the immediate neighborhood of interfering sources.

Signal leads must be carefully shielded, and should not be run in bundles with power or relay control leads.

#### **4.1.2 EMI**

The unit complies with all relevant regulations, as determined by the Policy of the European Committee for Electrotechnical Standardization (CENELEC), for the Electromagnetic Compatibility (2014/30/EU). Testing and inspection has been performed according to Standards EN 61000-4-2 and EN 61000-4-4. Thereby, the product meets all requirements to be marked by the CE sign.

Strict observance of these instructions during installation and use is an indispensable precondition hereto. Specifically to be observed:

Terminals must be kept off all undue access; power supply and all input and output leads must be protected against voltage interference, higher than specified operation data, and they must be protected against electrostatic discharge.

## **4.2 Safety Notes for Operation**

### **4.2.1 Safety Notes on Commissioning**

Commissioning must be carried out by sufficiently competent and qualified personnel.

During commissioning of the entire machine, the commissioning technician must ensure that the measuring chains function properly.

This consists of checking the correct speed display and checking the correct switch-off (tripping) with a stringent overspeed test. Correct switch-off (tripping) with an active external trip signal must also be checked with the voter.

The parameter settings must be protected against unauthorised alteration (password/code number) and the CRC must be documented via the parameter settings.

To ensure safe parameterisation of the system, it is necessary to verify correct transmission by reading back and comparing the values following transmission of the application-specific parameters.

## 5 Description of Monitor E1668

### 5.1 Display and Frontside Operational Elements

#### 5.1.1 Front View of Monitor E1668

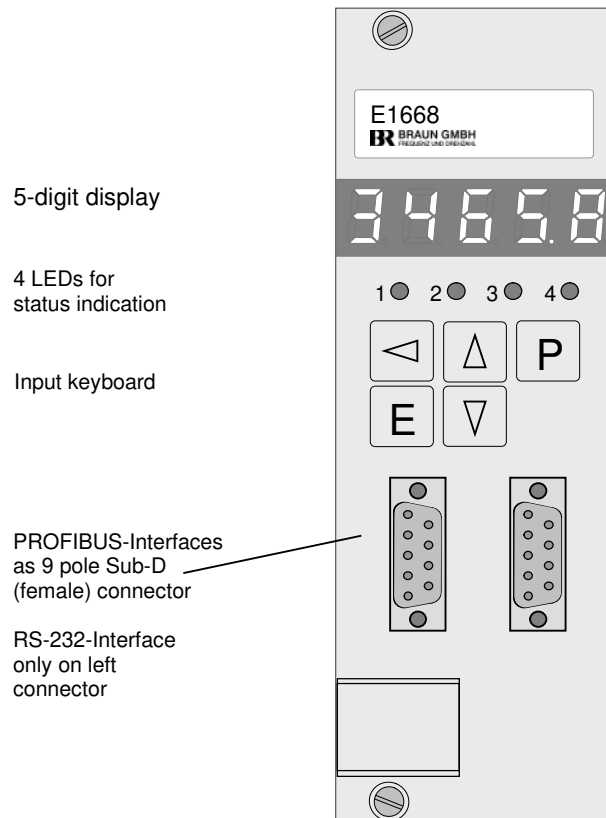

Figure 11: Front View of Monitor E1668

#### 5.1.2 Status-LEDs

LED1	steady on:	Trip
LED2	steady on:	no Trip SP1A is valid
	blinking:	SP1B is valid
LED3	steady on:	see parameter P05.05 of E1668
	blinking:	one only of three input channels measures zero speed
LED4		see parameter P05.05 of E1668

Note: If Monitor trip outputs are set to trip condition by Testgenerator, display reads CE-1 and LED status remains unchanged.

#### 5.1.3 Display during Test Procedures

CE-1	: Testgenerator actuates "Forced Trip"
FC-1	: Testgenerator tests Input "Forced Trip"
FC-3.1	: Trip-Line I is tested (relay I to Trip-Condition)
FC-3.2	: Trip-Line II is tested (relay II to Trip-Condition)
FC-3.4	: Trip-Line III is tested (relay III to Trip-Condition)
SELF	: Monitor self-test

### 5.1.4 Values accessible during normal operation

Values accessible during normal operation (Standard Display Mode):

- with key **[A]** : the value of SP1
- with key **[V]** : the value of SP2
- with keys **[A]** and **[E]** together: maximum stored speed value
- with keys **[V]** and **[E]** together: minimum stored speed value

**Note:**

- with key **[↵]** : reset of stored minimum/maximum value reset
- with keys **[↵]** and **[E]** together: reset of non persistent events (if enabled)
- with keys **[A]** and **[V]** together: toggle between Standard and Special Display Mode 1
- with keys **[A]** and **[P]** together: toggle between Standard and Special Display Mode 2

### 5.1.5 Special Display Mode 1

Toggle between Standard and Special Display Mode 1 by pressing keys **[A]** and **[V]** together. In Special Display Mode 1 the measured speed values of sensors A, B, C can be shown individually as well as the actual level of the main sensor signal input.

Toggle between the four values with **[E]** . In Special Display Mode 1 the LED assigned to the specific speed value is blinking (see table).

with Monitor	LED assigned to			
	speed value of sensor:			actual signal input level (in xx.x volts) LED4
	LED1	LED2	LED3	
A	A	C	B	A
B	B	A	C	B
C	C	B	A	C

### 5.1.6 Special Display Mode 2



Toggle between Standard and Special Display Mode 2 by pressing keys **[A]** and **[P]** together. In Special Display Mode 2 LED1 and LED4 are blinking. This display mode is only used for trouble shooting, if external signals are missing and the Monitor displays the event code E.0.4.0.0, see 11.2.

### 5.1.7 Display of Firmware release state and CRC-Parameter-Checksum of Monitor

with key **[P]** pressed longer as 5 seconds, the firmware release state and the CRC-Parameter-Checksum will be shown in a scrolled display:

- A.0383 (firmware ID)
- U.\_\_xx (xx = firmware version number)
- D.uu\_\_ (uu = year)
- D.\_vv\_ (vv = month)
- D.\_\_ww (ww = day of firmware release state)
- C.abcd (abcd = CRC-Parameter-Checksum)

### **5.1.8 Frontside Reset of Alarms and Event codes**

Resetting of (no longer valid) alarms and event codes is done by pressing keys  and  (if enabled in step P00.02).

### **5.1.9 Data Interface**

9pole Sub-D for PROFIBUS and RS232 (only on left connector).

## 5.2 Functions of Monitor E1668

For a detailed description of the individual functions refer to chapter 9.

### 5.2.1 Speed Measurement

Each Monitor receives the signal from the three sensors and calculates the speed from each signal. For the further evaluation it selects (depending on parameter settings) the calculated speed value derived of its own sensor or the mean value of all three speed values.

Speed calculation is done by measuring the time in between the pulses. The minimum measurement time is 5 milliseconds.

To compensate for an imperfect gear, a predivider may be introduced to reduce the signal frequency to 1 pulse per revolution.

### 5.2.2 Functions for Overspeed Protection

Overspeed protection is done by:

- Monitoring of Sensors
- Monitoring versus Lowspeed as protection versus incorrect mounting or fault of speed sensors
- Monitoring versus overspeed

### 5.2.3 Functions for External Trip by Voters

Trip is released, if one of the voters detects an external trip condition.

Voters may be configured as 1oo2, 2oo2, 2oo3 or 3oo3. High or low Input-Level as trip condition and response time is selectable.

### 5.2.4 Permanent Monitoring Functions

Each Monitor E1668 has the following permanent monitoring functions:

- Sensor monitoring (see parameter group P02.xx)
- Overspeed monitoring SP1 (see parameter group P03.xx)
- Lowspeed monitoring SP2 (see parameter group P04.xx)
- Speed limit monitoring SP3 (siehe parameter group P05.xx)
- Trip-Line monitoring (see P07.00 und P07.01)
- Forward/Reverse monitoring of sense of rotation (see P07.02 and P07.03)
- Current monitoring of analog output (only with E16x356.2xx, see P08.06)
- Monitoring of external trip release signals (see parameter group P10.xx and with E16x356.x2x parameter groups P11.xx through P15.xx)

### 5.2.5 Functional Tests

The Testgenerator E1698 initiates cyclic automatic test sequences which incorporates the Monitors E1668. These test sequences may be initiated also by an external signal or manually by the frontpanel of the Testgenerator.

Performed functional tests are:

- Trip-Line test sequence (de-energize of Trip-Lines I, II and III, see chapter 6.2.3)
- Monitor test sequence (overspeed test of SP1 and trip of Monitor, see chapter 6.2.2)

If during the Trip-Line test sequence a fault is detected, the system response will be according the setting of parameter P03.01 of E1698.

If during the Monitor test sequence a fault is detected, the system response will be according the setting of parameter P02.03 of E1698 respective P03.02 of E1668.

### 5.2.6 Selftest of Monitor

Selftest is performed at an interval of 2 hours. Execution of Selftest is signaled on display with message SELF. Selftest of the Monitors are inhibited versus each other.

The Selftest routine includes:

- CPU RAM Test
- CPU EEPROM Test
- CPU Command Test
- CPU Register Test
- Voter Inputsignal Test

If the Selftest detects a malfunction, the Monitor sets itself to trip-status.

## 6 Description of Testgenerator E1698

### 6.1 Display and Frontside Operational Elements

#### 6.1.1 Front View of Testgenerator E1698

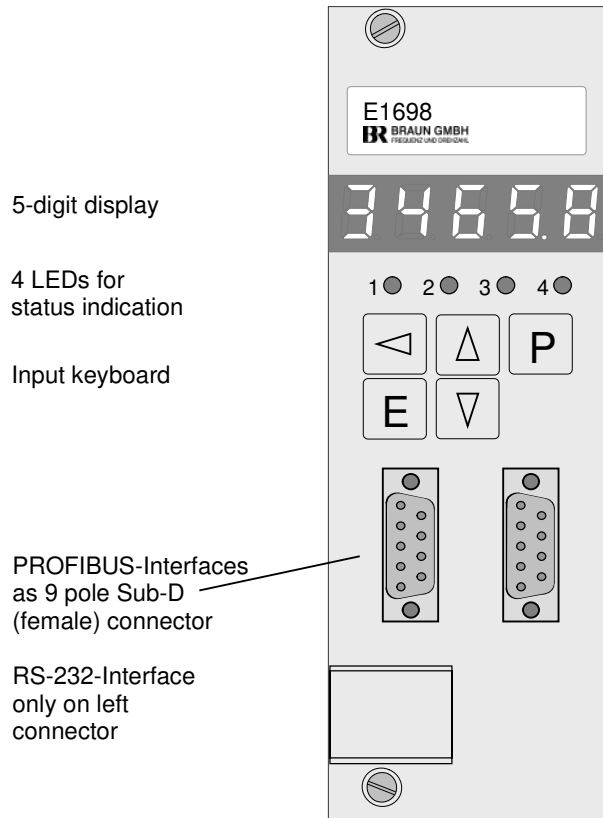

Figure 12: Front View of Testgenerator E1698

#### 6.1.2 Status-LEDs

LED1 blinking:	Test of Monitor A resp. Trip-Line I
steady on:	Monitor A signalizes Trip
LED2 blinking:	Test of Monitor B resp. Trip-Line II
steady on:	Monitor B signalizes Trip
LED3 blinking:	Test of Monitor C resp. Trip-Line III
steady on:	Monitor C signalizes Trip
LED4 blinking:	Test in preparation
steady on:	Monitor-AutoTest-Mode on
steady off:	Monitor-AutoTest-Mode off

### 6.1.3 Display during Test Procedures

FC-1 : Frequency generator tests Input "Forced Trip"  
FC-3.0 : Trip-Line Test in preparation  
FC-3.1 : Test Generator is testing Trip-Line I (relay I of all Monitors to Trip-Condition)  
FC-3.2 : Test Generator is testing Trip-Line II (relay II of all Monitors to Trip-Condition)  
FC-3.4 : Test Generator is testing Trip-Line III (relay III of all Monitors to Trip-Condition)

FC-3.3 : Inputs Test I and II are active (but test is inhibited)  
FC-3.5 : Inputs Test I and III are active (but test is inhibited)  
FC-3.6 : Inputs Test II and III are active (but test is inhibited)  
FC-3.7 : Inputs Test I and II and III are active (but test is inhibited)

FC-5.1 : Non-coincidence of test outputs detected  
FC-5.2 : Input Test Lock is active  
FC-5.4 : Input Test Lock was longer than 60 minutes active  
FC-5.6 : Input Test Lock is longer than 60 minutes active

SELF : Test-Generator self-test

### 6.1.4 Values accessible during normal operation

with key  : the value of test-speed 1 resp. SP1A,  
with key  : the value of test-speed 2 resp. SP1B,  
with keys  and  together: time remaining (in XXXX.X minutes) till start of the next Monitor-Test-Sequence),  
with keys  and  together: time remaining (in XXXX.X minutes) till start of the next Trip-Line-Test-Sequence).

### 6.1.5 Display of Firmware release state and CRC-Parameter-Checksum of Monitor

with key  pressed longer as 5 seconds, the firmware release state and the CRC-Parameter-Checksum will be shown in a scrolled display:

- A.0379 (firmware ID)
- U.\_\_xx (xx = firmware version number)
- D.uu\_\_ (uu = year )
- D.\_vv\_ (vv = month )
- D.\_\_ww (ww = day of firmware release state)
- C.abcd (abcd = CRC-Parameter-Checksum)

### 6.1.6 Frontside Reset of Alarms and Event codes

Resetting of (no longer valid) alarms and error messages is done by pressing keys  and  simultaneously.

### 6.1.7 Manual Start of a Monitor-Test Sequence

The test routine can be activated from the front of the test generator by pressing keys  and  simultaneously.

### 6.1.8 Manual Start of a Trip-Line-Test Sequence

The test routine can be activated from the front of the test generator by pressing keys  and  simultaneously.

### 6.1.9 Data Interface

9-pole Sub-D for PROFIBUS and RS232 (only on left connector).

## 6.2 Functions of Testgenerator 1698

For a detailed description of the individual functions refer to chapter 10.

### 6.2.1 Permanent Monitoring of Feedbacks

The Monitors signalize their trip respective warning status to the Testgenerator. The status of the three feedback signals from the Valve Control Circuits is also signalized to the Testgenerator. With system E16x356 the Valve Control Circuit feedback is in trip state as long as no external valve command is active. With the first valve command active, the feedback changes to no trip state. The Testgenerator permanently monitors these signals and will release its alarm outputs "System Warning Alarm 1" and "System Warning Alarm 2", if one or more of these signals do not show the expected state.

The sequence of the Monitor Test is inhibited during channel warning alarm of the monitors.

The sequence of the Trip-Line Test is inhibited during channel warning alarm of the monitors and during Valve Control Circuit fault.

### 6.2.2 Monitor-Test Sequence

During the Monitor-Test Sequence each monitor is sequentially subjected to a test sequence consisting of two simulated test-speeds followed by a 'Forced Trip' signal.

- Step 1: Each Monitor is sequentially provided with a test-speed 1 ( $n > SP1$ ) to which the Monitor under test must respond with trip release.
- Step 2: Each Monitor is sequentially provided with a test-speed 2 ( $n < SP1$ ) to which the Monitor under test must not respond with trip release.
- Step 3: The 'Forced Trip' control input of each Monitor is sequentially activated to which the Monitor under test must respond with trip release. During this step the Monitor is provided with test-speed 2 ( $n < SP1$ ).

In the event of an incorrect response the test will be discontinued and the Testgenerator releases the System Warning Alarm 1 and 2.

If variable setpoint SP1var is active, the test may be optionally performed according to the following steps:

- Step 1: Each Monitor is sequentially provided with a test-speed 1 ( $SP1A + 5 \text{ RPM}$ ) to which the Monitor under test must respond with trip release.
- Step 2: Each Monitor is sequentially provided with a test-speed 2 ( $SP1B - 5 \text{ RPM}$ ) to which the Monitor under test must not respond with trip release.
- Step 3: The 'Forced Trip' control input of each Monitor is sequentially activated to which the Monitor under test must respond with trip release. During this step the Monitor is provided with test-speed 2 ( $SP1B - 5 \text{ RPM}$ ).
- Step 4: Each Monitor is sequentially provided with a test-speed 3 ( $SP1A - 5 \text{ RPM}$ ) to which the Monitor under test must not respond with trip release.
- Step 5: Each Monitor is sequentially provided with a test-speed 4 ( $SP1B + 5 \text{ RPM}$ ) to which the Monitor under test must respond with trip release.

The time interval of these tests is programmable (see P02.02). The test sequence may also be started by an external signal „Start Auto Test Sequence“ or manually via frontside key-board of the Test-Generator.

### **6.2.3 Trip-Line-Test Sequence (Test of 2oo3 Solenoid Valve Block)**

The Testgenerator commands the Monitors to put sequentially the trip relays I, II or III to trip condition.

By doing so the designated Trip-Line to the 2oo3 Solenoid Valve is in trip condition.

The status of the 2oo3 Solenoid Valve is fed back to the Testgenerator.

The testing of Trip-Line I must provide the response of Solenoid Valve I.

The testing of Trip-Line II must provide the response of Solenoid Valve II.

The testing of Trip-Line III must provide the response of Solenoid Valve III.

In the event of an incorrect response the test will be discontinued and the Testgenerator releases the System Warning Alarm 1 and 2.

The interval between two automatic test sequences is selectable (see P03.00 of E1698). The test sequence may also be initiated by an external signal (terminal X8.5) or by frontpanel.

If externally initiated the sequence is executed automatically, subsequent after approx. 2 minutes the monitor test sequence is executed (see chapter 6.2.2).

### **6.2.4 Cross-check between CPUs of Test-Generator**

The Test-Generator incorporates two redundant CPUs. Both CPUs must perform identically to release a test sequence. In case of failure of one CPU no test is released, but System Warning Alarm 1 or 2 is released.

### **6.2.5 Selftest of CPUs**

Selftest is performed after each Monitor test sequence. Execution of Selftest is signaled on display with message SELF.

The Selftest of both CPU routine includes:

- CPU RAM Test
- CPU EEPROM Test
- CPU Command Test
- CPU Register Test

If the Selftest detects a malfunction, System Warning Alarm 1 or 2 is released.



## 8 Programming of the Modules

### Safety note:

To ensure safe programming of the system, it is always necessary following the transmission of the application-specific parameters to verify the correct application of the parameters in the monitor assemblies or the test generator assembly. This is carried out by showing the parameters on the display of the assemblies and by manually comparing the values to the application-specific parameter list.

### 8.1 Programming of the Modules via Front Keyboard

Principle: Select a parameter via its ,name' **Pgg.ss**,  
 in that **gg** = Parameter-group number and  
**ss** = Step-number within the group,  
 then display the value and alter if required.

#### Procedure:

Initiate programming phase by pressing keys **P** and **E** together;  
 instead of the normal display P00.00. appears

Select the group or step number with keys **Δ**, **∇**.

Switch between Groups and Step Fields with the **◀** key.

Current value of the Parameters is displayed with key **E**.

Select active position with the **◀** key.

Adjust the number in the active field with keys **Δ**, **∇**.

Acknowledge and set with key **E**, Discard (original value remains) with key **P**.

Return to operational mode with the **P** key. The display then returns to the current 'is' speed (with E1668) resp. to the current test-speed (with E1698)

**See example below:** Change parameter P01.01 from 2386 to 2387.

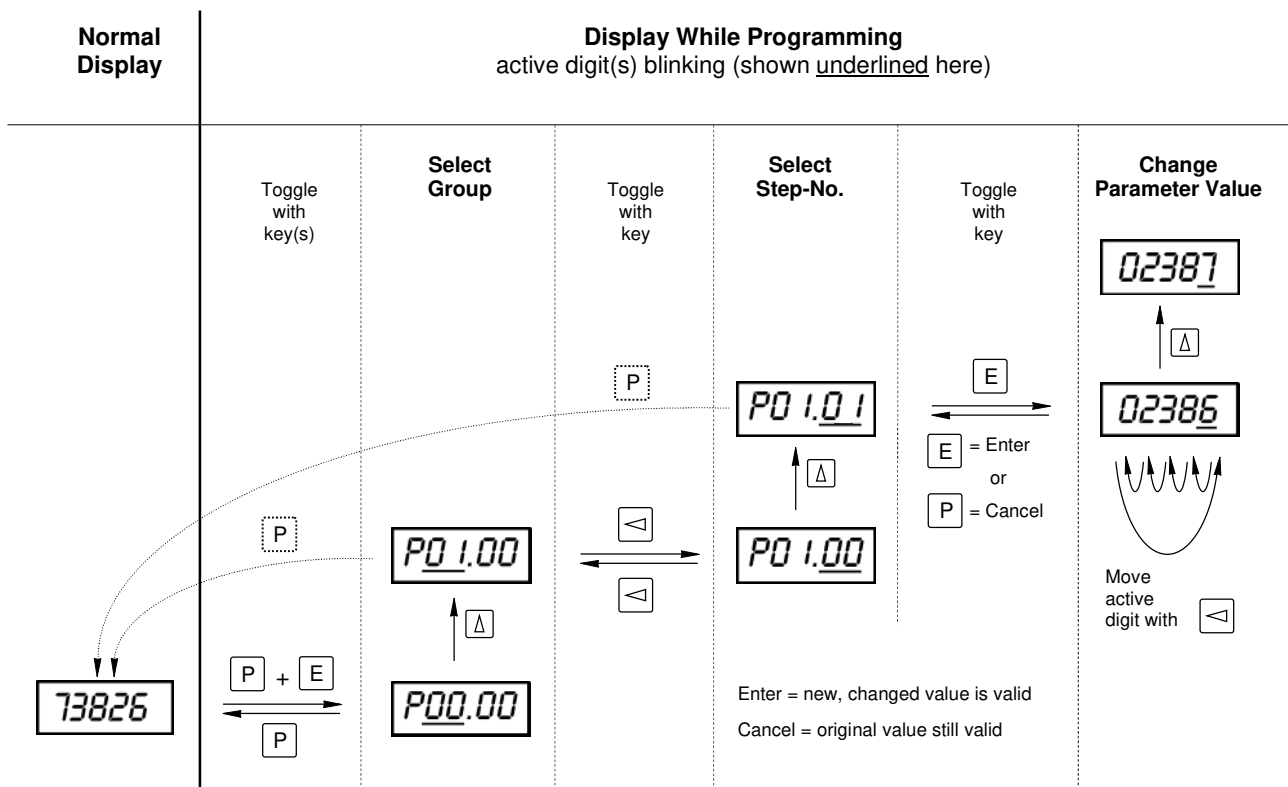

## 8.2 Programming of the Modules via RS232-Interface

Only possible for OEM with interface-software IS-RS232-E16 from BRAUN.

**Note:**

The RS232 Interface is implemented only on the left 9pole subD connector !!!

Connecting cable:

1. Cable L3D03 (2 an 3 crossed) and adapter L3D02

**Note:**

- Adapter L3D02 has male connectors on both sides.
- Cable L3D03 has female connectors to L3D02 and to PC.
- Any other cable must have following connections

PC Pin	2	to	3	E16
	3	to	2	
	5	to	5	(of 9 pole Sub-D connectors)

or

2. customized cable with connections PC (female connector) to E16 (male connector):

PC Pin	2	to	2	E16
	3	to	7	
	5	to	5	(of 9 pole Sub-D connectors)

**Note:**

The RS232-Interface serves only for parameter programming purposes, not for transmission of current data. States, alarms and measurement data are transmitted via PROFIBUS-Interface only.

## 8.3 Default Values

If not specified otherwise, the unit is supplied with default values as listed in the summary of parameters. In process of installation, the setting of its parameters inevitably must be adapted to the correct values according its application.

## 8.4 Response of Parameter if range of values is exceeded

If the admissible range of values is exceeded, the parameter value is blinking. The value will not be stored the previous set value is still valid.

## 8.5 Display of Parameter Values if front side parameter access is locked

If front side parameter access is locked, the values may be displayed but not changed. The parameter values are displayed blinking.

## 8.6 Safety Notes for Parameter Access during operation of the machine

- During operation of the machine the parameter access should be locked to prevent unauthorized access to the parameters.
- Access of parameters during operation of the machine may lead to an inadvertent trip, since the access disturbs the speed measurement (may result in overspeed trip of the Monitor).









Parameter Group P00.xx of Monitor E1668 Code Figure, Parameter Lock, Frontside Reset of Alarms	
Parameter No. Meaning of Parameter Setting Range of Parameter	Description of Parameters and their Settings
<b>P00.00</b> <b>Code Figure</b> Range: 0000 .. 9999	If the parameters are locked (see P00.02), the code figure must be entered prior to any change of other parameters. If the code figure is not correct, -E 1- is displayed. Without code figure and P00.02 : 0 the values of all parameters may be inspected, but not changed.
<b>P00.01</b> <b>New Code Figure</b> Range: 0000 .. 9999	A new code figure may be set in P00.01. Then it replaces the previous one.
<b>P00.02</b> <b>Parameter Lock</b> Range: 0 .. 1	Setting 0 : Parameters are locked, change only possible with code figure 1 : Parameters unlocked, change of parameter values possible
<b>P00.03</b> <b>Frontseitige Quittierung</b> Einstellbereich: 0 .. 1	Setting 0 : Frontside reset of alarms not possible 1 : Frontside reset of alarms possible with keys <b>E</b> and <b>←</b> .

<b>Parameter Group P01.xx of Monitor E1668 Input Scaling and Measurement Configuration</b>	
<b>Parameter No. Meaning of Parameter Setting Range of Parameter</b>	<b>Description of Parameters and their Settings</b>
<b>P01.00</b> Reserved for future applications	
<b>P01.01</b> <b>Nominal Input Frequency</b> Range: 00001 .. 99999 [Hz]	See description of Scaling.
<b>P01.02</b> <b>Decimals for P01.04, P04.00, P05.00 and for PROFIBUS Speed Data Output</b> Range: 0 .. 1	Setting 0 : Setting range for P01.04, P04.00, P05.00 : 00001 to 99999 RPM 1 : Setting range for P01.04, P04.00, P05.00 : 0000.1 to 9999.9 RPM  This setting is also valid for the number of decimals of the speed value transmitted via PROFIBUS.
<b>P01.03</b> <b>Nominal speed</b> Range: 00001 .. 99999 [RPM]	See description of Scaling.
<b>P01.04</b> <b>Lower Limit of the Speed Range</b> Range as defined in P01.02 [RPM]	If the monitored speed falls below the value entered here the measured value is given as 0 both for the display and the alarms. The lower limit of the speed range is entered in units of RPM.

Parameter Group P01.xx (continued) of Monitor E1668 Measurement Configuration	
Parameter No. Meaning of Parameter Setting Range of Parameter	Description of Parameters and their Settings
<b>P01.05</b> <b>Predivider</b> Range: 001 .. 255	The predivider is used only if the variable setpoint SP1var is active (P03.04 = 1). The predivider must then be set to the number of teeth of the gear wheel. The acceleration measurement is extended over one full rotation of the machine. <b>Note:</b> The predivider applies only to the primary measurement input. The two other measurement channels are not affected by the predivider.
<b>P01.06</b> Reserved for future application	
<b>P01.07</b> <b>Decimals for acceleration</b> Range: 0 .. 1	Setting 0 : setting of acceleration in XXXX RPM/sec 1 : setting of acceleration in XXX.X RPM/sec
<b>P01.08</b> <b>Maximum acceleration of the machine (dN/dt max)</b> Range: 00001 .. 99999 [RPM/sec] resp. 0000.1 .. 9999.9 [RPM/sec]	Setting is done in RPM/sec. Value must be set to the maximum possible acceleration (dN/dt max) of the machine in the worst case scenario. See also description of step P03.04
<b>P01.09</b> <b>No of acceleration measurements included in calculation of SP1var</b> Range: 1 .. 9	Recommended value is 1 or 2 measurements (equals to a measurement time of 20 or 40 milliseconds at a speed of 3000 RPM). More measurements included will improve the stability of the calculated setpoint SP1var, but also result in a delayed update rate.

Parameter Group P02.xx of Monitor E1668 Display, Starter time, Sensor Failure Monitoring	
Parameter No. Meaning of Parameter Setting Range of Parameter	Description of Parameters and their Settings
<b>P02.00</b> Reserved for future application	
<b>P02.01</b> <b>Display updating sequence</b> Range: 0.1 .. 9.9 [s]	The display may have its own independent up-dating sequence, different from the response time used by other functions - again in the interests of stabilized and legible readings. Set the parameter to the time required in steps of 0.1 sec. Recommended value is 0.3 sec. The display value is determined by the duration of a cycle sequence. The rapid response of the alarms is not influenced by this procedure.
<b>P02.02</b> <b>Starter Time Period</b> Range: 000 .. 999 [s]	This step sets the starter time period (duration). The starter phase state for SP2 lasts from the beginning of the external starter signal plus the programmed time elapse following its end.
<b>P02.03</b> Fix value = 1, do not change	
<b>P02.04</b> <b>Sensor Monitoring (Current and Signal Level)</b> Range: 0 .. 4	A sensor fault will be reported according to the designated parameters and, if configured, latched until the reset is activated. Setting 0 : Monitoring disabled 1 : Not permissible 2 : Fault reported + Trip release, latched till reset 3 : Not permissible 4 : Fault reported without trip release (recommended setting)
<b>P02.05</b> <b>Mode of Sensor Monitoring</b> Range: 0 .. 7	Setting 0 : Without monitoring (see note 3) 1 : Checks sensor current drain 2 : Checks signal voltage level at stand still (see note 1) 3 : Current drain and voltage level 4 : Inductive sensor (MPU) 5 : Reserved for future use 6 : Eddy sensor voltage level (see note 2) 7 : Eddy sensor voltage level and current drain (see note 2)  <b>Note 1:</b> The voltage level check is only possible with RAUN-sensor type A5S... . In this instance even at stand still a defective sensor or supply cable can be detected. <b>Note 2:</b> The signal voltage level (and current drain) is compared versus max/min-values as set in P06.01 to P06.04. <b>Note 3:</b> Selection of Setting 0 makes Step P02.04 meaningless.

**Parameter Group P02.xx (continued) of Monitor E1668**  
**Sensor Failure Monitoring**

<b>Parameter No.</b> <b>Meaning of Parameter</b> Setting Range of Parameter	<b>Description of Parameters and their Settings</b>
<p><b>P02.06</b>  <b>Lowspeed Monitoring</b>  <b>"n &lt; SP2"</b>                      Range: 0 .. 4</p>	<p><b>Safety Note:</b>  <b>The Lowspeed Monitoring "n &lt; SP2" is the only comprehensive protection versus a systematic fault of any type of speed sensor (no speed signal from sensor at running machine).</b>  <b>Setting of P02.06 = 0 is allowed only for test purposes during commissioning of the machine. In normal operation P02.06 must be set to a value of 1 or 2 or 3 or 4.</b></p> <p><b>Function of Lowspeed Monitoring "n &lt; SP2":</b>                      Following the end of the Starter phase (Start-Up Bridging) the measured speed must exceed the value set for SP2. If the measured speed n is then lower than SP2, trip is released.</p> <p><b>Function of Starter Plausibility Check:</b>                      If</p> <ul style="list-style-type: none"> <li>• starter condition is true</li> <li>• and plausibility check is on</li> <li>• and speed exceeds 50% of overspeed setpoint SP1A</li> </ul> <p>then                      Monitor Warning Alarm is released by plausibility check and event code E.3.0.1.0 is displayed.</p> <p>Setting</p> <ul style="list-style-type: none"> <li>0 : Monitoring switched off (<b>not permissible, see safety note above</b>)</li> <li>1 : Trip and Alarm till rectified, starter plausibility check on</li> <li>2 : Trip and Alarm latched, starter plausibility check on</li> <li>3 : Trip and Alarm, till rectified / starter plausibility check off</li> <li>4 : Trip and Alarm latched / starter plausibility check off</li> </ul>

**Parameter Group P02.xx (continued) of Monitor E1668**  
**Sensor Failure Monitoring**

<b>Parameter No.</b> <b>Meaning of Parameter</b> Setting Range of Parameter	<b>Description of Parameters and their Settings</b>
<p><b>P02.07</b>  <b>Speed Comparison</b>  <b>Evaluation Mode</b>            Range: 0 .. 5</p>	<p>Speed comparison of the 3 sensors enables:</p> <ul style="list-style-type: none"> <li>• Detection of incorrect installation of the sensor (distance from the tooth wheel too large or wrong position) even during the start-up bridging phase</li> <li>• Detection of a fading function of a sensor during normal operation</li> </ul> <p>Functionality:            Each Monitor has three measuring channels and receives the signals of all three sensors.</p> <p>Setting</p> <p>0 : only the primary sensor will be evaluated; no redundancy.            1 : Trip is released if primary sensor fault is detected.            2 : only error message is released if primary sensor fault is detected, but only speed value of primary sensor is used for further evaluation.            3 : not permissible            4 : only error message is released if primary sensor fault is detected, but the mean value of the three speed values is used for further evaluation.            5 : same as setting 4, but a trip released due to deviation is latched.</p> <p>Setting 1 or 2 or 4 or 5:            During machine operation each Monitor compares its sensor input with those of its two neighbors. If the measured speed value of its own (primary) sensor in comparison with its two neighbors produces a discrepancy exceeding the tolerance level set at P02.08, the monitor's primary sensor will be reported as faulty.            However, should all three measured speed values deviate from each other for more than the specified tolerance, the monitor will release trip.</p> <p><b>Note:</b>            Setting P02.07 = 4 or 5 avoids a trip release caused by a sensor fault during the automatic test procedure and are recommended settings.</p> <p><b>Example:</b>            Monitor A is tested for overspeed, at the same time the signal from sensor B drops out. Monitor B reports an error, but continues to evaluate the signals from sensors A and C.</p>

**Parameter Group P02.xx (continued) of Monitor E1668**  
**Sensor Failure Monitoring**

<b>Parameter No.</b> <b>Meaning of Parameter</b> Setting Range of Parameter	<b>Description of Parameters and their Settings</b>																														
<b>P02.08</b> <b>Permissible Speed Difference between Sensors</b> Range: 001 .. 999 [RPM]	Value for the permissible difference in RPM between the speed measurement of the primary sensor and that of the other two sensors before a fault is detected. <b>Note:</b> Primary sensor is the sensor the monitor supplies with power.																														
<b>P02.09</b> <b>Number of tests until alarm</b> Range: 01 .. 99	Number of consecutively failed speed comparison tests which may occur before an error message is issued. <b>Note:</b> At speeds lower than 50% of the nominal speed, the number of tests is automatically increased to avoid incorrect alarms during acceleration phase of the machine.  <b>Example for Setting of P02.07 = 4:</b> P02.08 = 030 (permissible difference between measured values = 30 RPM) P02.09 = 5 (Number of consecutive errors till error message issued)  With the example above an error message will be issued when the speed value of the primary sensor deviates by 30 RPM from the two other measured sensors five measurements in succession. When all three measurements of one monitor between themselves differ by more than 30 RPM (measurement of sensor A = 6031 RPM, of sensor B = 6000 RPM, of sensor C = 5969 RPM), the monitor will release trip.																														
<b>P02.10</b> <b>Monitor Warning Alarm also at Trip Condition</b> Range: 0 .. 4	Setting depends on how the alarm is used according the specific application for detection of SOE (sequence of events). <table border="1" data-bbox="587 1317 1412 1615"> <thead> <tr> <th>Setting</th> <th>Alarm at Overspeed-Trip</th> <th>Alarm at Voter-Trip</th> <th>Alarm at Trip due to Trip-Line-Monitoring</th> <th>Alarm at Lowspeed-Trip</th> </tr> </thead> <tbody> <tr> <td>0</td> <td>No</td> <td>No</td> <td>Yes</td> <td>Yes</td> </tr> <tr> <td>1</td> <td>Yes</td> <td>Yes</td> <td>Yes</td> <td>Yes</td> </tr> <tr> <td>2</td> <td>No</td> <td>No</td> <td>No</td> <td>Yes</td> </tr> <tr> <td>3</td> <td>Yes</td> <td>Yes</td> <td>No</td> <td>Yes</td> </tr> <tr> <td>4</td> <td>No</td> <td>No</td> <td>No</td> <td>No</td> </tr> </tbody> </table> <b>Note:</b> The Monitor Warning Alarm is always released in case of detected sensor fault.	Setting	Alarm at Overspeed-Trip	Alarm at Voter-Trip	Alarm at Trip due to Trip-Line-Monitoring	Alarm at Lowspeed-Trip	0	No	No	Yes	Yes	1	Yes	Yes	Yes	Yes	2	No	No	No	Yes	3	Yes	Yes	No	Yes	4	No	No	No	No
Setting	Alarm at Overspeed-Trip	Alarm at Voter-Trip	Alarm at Trip due to Trip-Line-Monitoring	Alarm at Lowspeed-Trip																											
0	No	No	Yes	Yes																											
1	Yes	Yes	Yes	Yes																											
2	No	No	No	Yes																											
3	Yes	Yes	No	Yes																											
4	No	No	No	No																											
<b>P02.11</b> <b>Latching of Monitor Warning Alarm and Error Messages</b> Range: 0 .. 2	The Monitor Warning Alarm and the error message can be latched.  Setting 0 : no 1 : yes, in this case all occurring errors are shown in the display as error combinations 2 : yes, in this case only the first occurring error is displayed																														



**Parameter Group P03.xx (continued) of Monitor E1668**  
**Overspeed Alarm SP1**

<b>Parameter No.</b> <b>Meaning of Parameter</b> Setting Range of Parameter	<b>Description of Parameters and their Settings</b>														
<p><b>P03.04</b>  <b>Overspeed Setpoint SP1var</b>  <b>not active / active</b>                      Range: 0 .. 1</p> <p><b>Attention:</b>  <b>If P03.04 = 1: The value of SP1A (P03.00) must not be lower than the value of SP1B (P03.03), else SP1B will always be valid during acceleration phase.</b></p>	<p>Setting                      0 : not active                      1 : active</p> <p>If the overspeed setpoint SP1var is not active, then SP1A is valid (respective SP1B as long as the input "SP1B valid" is true).                      If the overspeed setpoint SP1var is active, it is calculated depending on the measured acceleration in between the limits of SP1A and SP1B.                      If acceleration <math>dN/dt = 0</math> , then <math>SP1var = SP1A</math>.                      If acceleration <math>dN/dt = dN/dt \text{ max}</math> , then <math>SP1var = SP1B</math>.</p> <p><b>Example:</b>  <math>dN/dt \text{ max} = 300 \text{ RPM/sec}</math>  <math>SP1B = 3090 \text{ RPM}</math> (at acceleration rate of <math>300 \text{ RPM/sec}</math>)  <math>SP1A = 3240 \text{ RPM}</math> (at acceleration rate of <math>0 \text{ RPM/sec}</math>)</p> <table border="1" data-bbox="603 969 1347 1296"> <thead> <tr> <th>measured acceleration</th> <th>calculated value SP1var</th> </tr> </thead> <tbody> <tr> <td>300 RPM/s</td> <td>3090 RPM</td> </tr> <tr> <td>240 RPM/s</td> <td>3120 RPM</td> </tr> <tr> <td>180 RPM/s</td> <td>3150 RPM</td> </tr> <tr> <td>120 RPM/s</td> <td>3180 RPM</td> </tr> <tr> <td>60 RPM/s</td> <td>3210 RPM</td> </tr> <tr> <td>0 RPM/s</td> <td>3240 RPM</td> </tr> </tbody> </table> <p>See also graph below</p>	measured acceleration	calculated value SP1var	300 RPM/s	3090 RPM	240 RPM/s	3120 RPM	180 RPM/s	3150 RPM	120 RPM/s	3180 RPM	60 RPM/s	3210 RPM	0 RPM/s	3240 RPM
measured acceleration	calculated value SP1var														
300 RPM/s	3090 RPM														
240 RPM/s	3120 RPM														
180 RPM/s	3150 RPM														
120 RPM/s	3180 RPM														
60 RPM/s	3210 RPM														
0 RPM/s	3240 RPM														

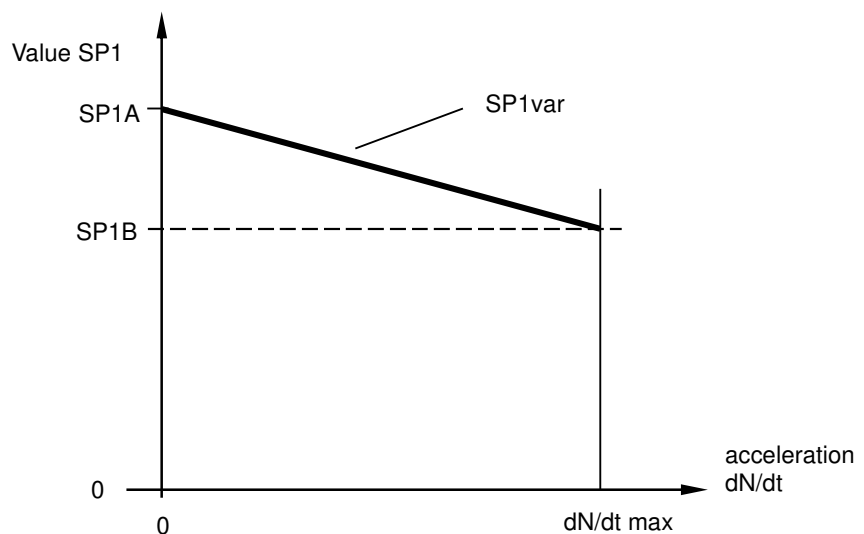

Figure 13:  
 SP1 as a variable  
 of the acceleration

Parameter Group P04.xx of Monitor E1668 Lowspeed Alarm SP2	
Parameter No. Meaning of Parameter Setting Range of Parameter	Description of Parameters and their Settings
<b>P04.00</b> <b>Lowspeed Setpoint SP2</b> Range: 00001 .. 99999 [RPM]	The numerical value for the setpoint SP2 is expressed as RPM).
<b>P04.01</b> <b>Alarm Hysteresis Width in XX.X % of SP2</b> Range: 00.1 .. 99.9 [%]	The hysteresis is the margin between condition "excess" (>) and "no excess" (<), defined by its bandwidth. The width of hysteresis is set as a percentage of the switching point. The position of the hysteresis of SP2 is determined above the setpoint.  <b>Example:</b> With 5% Hysteresis and a setpoint of 100 RPM a Lowspeed alarm is issued once speed drops below 100 RPM and ceases once speed exceeds 105 RPM.
<b>P04.02</b> Fix value = 0, do not change	

<b>Parameter Group P05.xx of Monitor E1668 Alarm SP3</b>	
<b>Parameter No. Meaning of Parameter Setting Range of Parameter</b>	<b>Description of Parameters and their Settings</b>
<b>P05.00 Setpoint SP3</b> Range: 00001 .. 99999 [RPM]	The numerical value for the setpoint SP3 is expressed as RPM.
<b>P05.01 Alarm Hysteresis Width in XX.X % of SP3</b> Range: 00.1 .. 99.9 [%]	The hysteresis is the margin between condition "excess" (>) and "no excess" (<), defined by its bandwidth. The width of hysteresis is set as a percentage of the switching point.
<b>P05.02 Hysteresis position</b> Range: 0 .. 1	The hysteresis band for SP3 may be placed above or below setpoint.  Setting 0 : Hysteresis above SP3 1 : Hysteresis below SP3
<b>P05.03 Relay State at n &gt; SP3</b> Range: 0 .. 3	Setting 0 : Relay energized if n > SP3, setpoint follows test speed 1 : Relay de-energized if n > SP3, setpoint follows test speed 2 : Relay energized if n > SP3, setpoint is frozen during test speed 3 : Relay de-energized if n > SP3, setpoint is frozen during test speed
<b>P05.04 Alarm State at Sensor Error Condition</b> Range: 0 .. 2	If a sensor fault is detected, alarm SP3 can be forced into a defined state.  Setting 0 : Alarm SP3 according to measured rotational speed 1 : Alarm SP3 forced to state n < SP3 2 : Alarm SP3 forced to state n > SP3
<b>P05.05 Status of LEDs 3 and 4 for Alarm n &gt; SP3</b> Range: 0 .. 1	Setting 0 : LED3 (green) on at n > SP3 1 : LED4 (red) on at n > SP3

Parameter Group P06.xx of Monitor E1668 Eddy sensor input and MPU input	
Parameter No. Meaning of Parameter Setting Range of Parameter	Description of Parameters and their Settings
<b>P06.00</b> Reserved for future application	
	Eddy sensors must not be operated outside (manufacturer) specified limits of voltage level and supply current. These limits can be checked (see parameter P02.05).
<b>P06.01</b> <b>Input voltage upper limit</b> Range: 00.0 .. 24.0 [V]	Input check:     input voltage upper limit    in xx.x volts
<b>P06.02</b> <b>Input voltage lower limit</b> Range: 00.0 .. 24.0 [V]	input voltage lower limit    in xx.x volts
<b>P06.03</b> <b>Current drain upper limit</b> Range: 000 .. 120 [mA]	current drain upper limit    in xxx ma
<b>P06.04</b> <b>Current drain lower limit</b> Range: 000 .. 120 [mA]	current drain lower limit    in xxx ma
<b>P06.05</b> <b>Signal input hysteresis</b> Einstellbereich: 0.0 .. 2.5 [Vpp]	Signal input hysteresis (sensitivity level) in x.x volts.  <b>Note:</b> <b>The trigger hysteresis must be larger than possible noise on the speed signal.</b>  <b>Note:</b> with setting 0.0 hysteresis is approx 70 millivolts.

Parameter Group P07.xx of Monitor E1668 Trip-Line-Monitoring, Rotational Direction Output	
Parameter No. Meaning of Parameter Setting Range of Parameter	Description of Parameters and their Settings
<b>P07.00</b> <b>Trip-Line-Monitoring</b> Range: 0 .. 3	<p>If activated the Monitor checks the output of the Trip-Lines. If two or three Trip-Lines indicate trip condition the monitor moves to trip status (Trip Lock Function). Following the reset signal the monitor releases the trip state for one second. Within this time the feedback signal must respond correctly, otherwise the monitor returns to trip status.</p> <p>Setting</p> <ul style="list-style-type: none"> <li>0 : Trip-Line-Monitoring not active</li> <li>1 : Trip-Line-Monitoring active, with response time until trip = 50 ms</li> <li>2 : not admissible</li> <li>3 : Trip-Line-Monitoring active, with response time until trip = 3 ms</li> </ul>
<b>P07.01</b> <b>Trip-Line Level at Trip-Status</b> Range: 0 .. 1	<p>Setting</p> <ul style="list-style-type: none"> <li>0 : Low Level at Trip-Status (relays de-energized to Trip)</li> <li>1 : High-Level at Trip-Status (relays energized to Trip)</li> </ul>
<b>P07.02</b> <b>Signal-Input Level for Rotational Direction Detection</b> Range: 0 .. 1	<p>Setting</p> <ul style="list-style-type: none"> <li>0 : Signal level low is assigned to forward motion</li> <li>1 : Signal level high is assigned to forward motion</li> </ul> <p><b>Note:</b> Each monitor evaluates the F/R signals of all three sensors in 2oo3.</p>
<b>P07.03</b> <b>Relay State for status forward motion</b> Range: 0 .. 1	<p>Setting</p> <ul style="list-style-type: none"> <li>0 : Relay de-energized at status forward motion (Contact opened)</li> <li>1 : Relay energized at status forward motion (Contact closed)</li> </ul>
<b>P07.04</b> Reserved for future application	

<b>Parameter Group P08.xx of Monitor E1668 Analog Output</b>	
<b>Parameter No. Meaning of Parameter Setting Range of Parameter</b>	<b>Description of Parameters and their Settings</b>
<b>P08.00 High End of Analog Output</b> Range: 00001 .. 99999 [RPM]	The high end defines the speed (in terms of RPM) at which the analog output delivers 20 ma (with P08.04 = 0), resp. 0 / 4 ma (with P08.04 = 1).
<b>P08.01 Low End of Analog Output</b> Range: 00000 .. 99999 [RPM]	The low end defines the speed (in terms of RPM) at which the analog output delivers 0 resp. 4 ma (with P08.04 = 0), resp. 20 ma (with P08.04 = 1).
<b>P08.02 Analog Output Zero Level</b> Range: 0 .. 1	Setting 0 : without live zero (0..20 ma) 1 : with live zero (4..20 ma)
<b>P08.03 Output Level at Sensor Fault</b> Range: 0 .. 2	Setting 0 : no change of output 1 : output goes to 0,0 ma 2 : output goes to > 20,8 ma
<b>P08.04 Direction of Analog Output</b> Range: 0 .. 1	Setting 0 : output is increasing with increasing speed (0/4 ...20 ma) 1 : output is decreasing with increasing speed (20....4/0 ma)
<b>P08.05 Output Response at Test-speed</b> Range: 0 .. 1	Setting 0 : output follows test speed 1 : output is frozen (on last value before test starts) during test speed
<b>P08.06 Prüfung Test of Analog Output Value</b> Range: 0 .. 1	Analog output may be checked for short circuit or no load or its correct output, detected via integrated control feedback. Setting 0 : output value is not tested (mandatory with versions E1668.0xx respective E1668.1xx) 1 : value of output is tested (only possible with versions E1668.2xx)

Parameter Group P09.xx of Monitor E1668 Reserved for future application	
Parameter No. Meaning of Parameter Setting Range of Parameter	Description of Parameters and their Settings
<b>P09.00</b> Reserved for future application	

**Parameter Group P10.xx of Monitor E1668  
Voter 1 and Logic Output LO1**

<b>Parameter No.</b> <b>Meaning of Parameter</b> Setting Range of Parameter	<b>Description of Parameters and their Settings</b>																													
<b>P10.00</b> <b>Operation mode Voter 1</b> Range: 0 .. 5	Setting 0 : Voter inactive 1 : always active (over entire speed range) 2 : Voter only active, if n > SPV1 3 : Voter only active, if n < SPV1 4 : Voter inactive, output LO1 low, if n > SPV1 5 : Voter inactive, output LO1 high, if n > SPV1																													
<b>P10.01</b> <b>Input Truth Level</b> Range: 0 .. 1	Setting 0 : high level at inputs is assigned to trip condition 1 : low level at inputs is assigned to trip condition																													
<b>P10.02</b> <b>Voting Logic</b> Range: 0 .. 3	Selectable Voting Logics are: <ul style="list-style-type: none"> <li>• 1oo2 : trip is released if 1 of 2 inputs signalizes trip condition</li> <li>• 2oo2 : trip is released if 2 of 2 inputs signalize trip condition</li> <li>• 2oo3 : trip is released if 2 of 3 inputs signalize trip condition</li> <li>• 3oo3 : trip is released if 3 of 3 inputs signalize trip condition</li> </ul> Setting 0 : 1oo2 (only inputs 1 and 2 of voter 1 are monitored) 1 : 2oo2 (only inputs 1 and 2 of voter 1 are monitored) 2 : 2oo3 (all three inputs of voter 1 are monitored) 3 : 3oo3 (all three inputs of voter 1 are monitored)																													
<b>P10.03</b> <b>Truth Time until Trip</b> Range: 0 .. 7	If the trip signal is shorter than the minimum truth time, the signal is not valid (anti bouncing filter). If the signal is longer than the maximum truth time, the signal is valid and trip is released Note: Signal truth times in between min. and max. may release trip. <table border="1" data-bbox="986 1200 1410 1532" style="float: right; margin-top: 10px;"> <thead> <tr> <th rowspan="2">Setting</th> <th colspan="2">Trip after</th> </tr> <tr> <th>min.</th> <th>max.</th> </tr> </thead> <tbody> <tr> <td>0</td> <td>0 msec</td> <td>4 msec</td> </tr> <tr> <td>1</td> <td>3 msec</td> <td>12 msec</td> </tr> <tr> <td>2</td> <td>9 msec</td> <td>36 msec</td> </tr> <tr> <td>3</td> <td>18 msec</td> <td>54 msec</td> </tr> <tr> <td>4</td> <td>36 msec</td> <td>108 msec</td> </tr> <tr> <td>5</td> <td>72 msec</td> <td>216 msec</td> </tr> <tr> <td>6</td> <td>144 msec</td> <td>432 msec</td> </tr> <tr> <td>7</td> <td>288 msec</td> <td>864 msec</td> </tr> </tbody> </table> Maximum response time until trip-lines go to trip status is maximum truth time + 3 milliseconds	Setting	Trip after		min.	max.	0	0 msec	4 msec	1	3 msec	12 msec	2	9 msec	36 msec	3	18 msec	54 msec	4	36 msec	108 msec	5	72 msec	216 msec	6	144 msec	432 msec	7	288 msec	864 msec
Setting	Trip after																													
	min.	max.																												
0	0 msec	4 msec																												
1	3 msec	12 msec																												
2	9 msec	36 msec																												
3	18 msec	54 msec																												
4	36 msec	108 msec																												
5	72 msec	216 msec																												
6	144 msec	432 msec																												
7	288 msec	864 msec																												
<b>P10.04</b> <b>Trip by Voter 1 latched</b> Range: 0 .. 1	Setting 0 : trip by voter 1 is not latched 1 : trip by voter 1 is latched until reset																													

Parameter Group P10.xx (continued) of Monitor E1668 Voter 1 and Logic Output LO1	
Parameter No. Meaning of Parameter Setting Range of Parameter	Description of Parameters and their Settings
<b>P10.05</b> <b>Delay of Antivalence Alarm</b> Range: 0 .. 9	<p>To avoid unnecessary Antivalence Alarms due to shifted trip release signals at the voter inputs a delay may be introduced. Antivalence alarm will then be released only if the time shift between the signals exceeds the set delay.</p> <p>Setting</p> <ul style="list-style-type: none"> <li>0 : no delay</li> <li>1 : delay = 100 milliseconds</li> <li>2 : delay = 500 milliseconds</li> <li>3 : delay = 1 second</li> <li>4 : delay = 2 seconds</li> <li>5 : delay = 3 seconds</li> <li>6 : delay = 5 seconds</li> <li>7 : delay = 15 seconds</li> <li>8 : delay = 30 seconds</li> <li>9 : delay = 60 seconds</li> </ul> <p><b>Note:</b> The input signals will be monitored for antivalence only, if the voter is active.</p>
<b>P10.06</b> <b>Setpoint SPV1</b> Range: 00000 .. 99999 [RPM]	<p>Depending on setting of P10.00, SPV1 controls the activity of voter 1 or controls directly the output LO1. SPV1 is set in terms of RPM.</p>
<b>P10.07</b> Reserved for future application	
<b>P10.08</b> Reserved for future application	

**Parameter Group P11.xx of Monitor E1668  
Voter 2 and Logic Output LO2**

<b>Parameter No. Meaning of Parameter Setting Range of Parameter</b>	<b>Description of Parameters and their Settings</b>																													
<b>P11.00</b> <b>Operation mode Voter 2</b> Range: 0 .. 5	Setting 0 : Voter inactive 1 : Voter always active (over entire speed range) 2 : Voter only active, if n > SPV2 3 : Voter only active, if n < SPV2 4 : Voter inactive, output LO2 low, if n > SPV2 5 : Voter inactive, output LO2 high, if n > SPV2																													
<b>P11.01</b> <b>Input Truth Level</b> Range: 0 .. 1	Setting 0 : high level at inputs is assigned to trip condition 1 : low level at inputs is assigned to trip condition																													
<b>P11.02</b> <b>Voting Logic</b> Range: 0 .. 3	Selectable Voting Logics are: <ul style="list-style-type: none"> <li>• 1oo2 : trip is released if 1 of 2 inputs signalizes trip condition</li> <li>• 2oo2 : trip is released if 2 of 2 inputs signalize trip condition</li> <li>• 2oo3 : trip is released if 2 of 3 inputs signalize trip condition</li> <li>• 3oo3 : trip is released if 3 of 3 inputs signalize trip condition</li> </ul> Setting 0 : 1oo2 (only inputs 1 and 2 of voter 2 are monitored) 1 : 2oo2 (only inputs 1 and 2 of voter 2 are monitored) 2 : 2oo3 (all three inputs of voter 2 are monitored) 3 : 3oo3 (all three inputs of voter 2 are monitored)																													
<b>P11.03</b> <b>Truth Time until Trip</b> Range: 0 .. 7	If the trip signal is shorter than the minimum truth time, the signal is not valid (anti bouncing filter). If the signal is longer than the maximum truth time, the signal is valid and trip is released Note: Signal truth times in between min. and max. may release trip. <table border="1" data-bbox="986 1198 1412 1534"> <thead> <tr> <th rowspan="2">Setting</th> <th colspan="2">Trip after</th> </tr> <tr> <th>min.</th> <th>max.</th> </tr> </thead> <tbody> <tr> <td>0</td> <td>0 msec</td> <td>4 msec</td> </tr> <tr> <td>1</td> <td>3 msec</td> <td>12 msec</td> </tr> <tr> <td>2</td> <td>9 msec</td> <td>36 msec</td> </tr> <tr> <td>3</td> <td>18 msec</td> <td>54 msec</td> </tr> <tr> <td>4</td> <td>36 msec</td> <td>108 msec</td> </tr> <tr> <td>5</td> <td>72 msec</td> <td>216 msec</td> </tr> <tr> <td>6</td> <td>144 msec</td> <td>432 msec</td> </tr> <tr> <td>7</td> <td>288 msec</td> <td>864 msec</td> </tr> </tbody> </table> Maximum response time until trip-lines go to trip status is maximum truth time + 3 milliseconds.	Setting	Trip after		min.	max.	0	0 msec	4 msec	1	3 msec	12 msec	2	9 msec	36 msec	3	18 msec	54 msec	4	36 msec	108 msec	5	72 msec	216 msec	6	144 msec	432 msec	7	288 msec	864 msec
Setting	Trip after																													
	min.	max.																												
0	0 msec	4 msec																												
1	3 msec	12 msec																												
2	9 msec	36 msec																												
3	18 msec	54 msec																												
4	36 msec	108 msec																												
5	72 msec	216 msec																												
6	144 msec	432 msec																												
7	288 msec	864 msec																												
<b>P11.04</b> <b>Trip by Voter 2 latched</b> Range: 0 .. 1	Setting 0 : trip by voter 2 is not latched 1 : trip by voter 2 is latched until reset																													

Parameter Group P11.xx (continued) of Monitor E1668 Voter 2 and Logic Output LO2	
Parameter No. Meaning of Parameter Setting Range of Parameter	Description of Parameters and their Settings
<b>P11.05</b> <b>Delay of Antivalence Alarm</b> Range: 0 .. 9	<p>To avoid unnecessary Antivalence Alarms due to shifted trip release signals at the voter inputs a delay may be introduced. Antivalence alarm will then be released only if the time shift between the signals exceeds the set delay.</p> <p>Setting</p> <ul style="list-style-type: none"> <li>0 : no delay</li> <li>1 : delay = 100 milliseconds</li> <li>2 : delay = 500 milliseconds</li> <li>3 : delay = 1 second</li> <li>4 : delay = 2 seconds</li> <li>5 : delay = 3 seconds</li> <li>6 : delay = 5 seconds</li> <li>7 : delay = 15 seconds</li> <li>8 : delay = 30 seconds</li> <li>9 : delay = 60 seconds</li> </ul> <p><b>Note:</b> The input signals will be monitored for antivalence only, if the voter is active.</p>
<b>P11.06</b> <b>Setpoint SPV2</b> Range: 00001 .. 99999 [RPM]	<p>Depending on setting of P11.00, SPV2 controls the activity of voter 2 or controls directly the output LO2. SPV2 is set in terms of RPM.</p>
<b>P11.07</b> Reserved for future application	
<b>P11.08</b> Reserved for future application	

**Parameter Group P12.xx of Monitor E1668  
Voter 3 and Logic Output LO3**

Parameter No. Meaning of Parameter Setting Range of Parameter	Description of Parameters and their Settings																													
<b>P12.00</b> <b>Operation mode Voter 3</b> Range: 0 .. 5	Setting 0 : Voter inactive 1 : Voter always active (over entire speed range) 2 : Voter only active, if n > SPV3 3 : Voter only active, if n < SPV3 4 : Voter inactive, output LO3 low, if n > SPV3 5 : Voter inactive, output LO3 high, if n > SPV3																													
<b>P12.01</b> <b>Input Truth Level</b> Range: 0 .. 1	Setting 0 : high level at inputs is assigned to trip condition 1 : low level at inputs is assigned to trip condition																													
<b>P12.02</b> <b>Voting Logic</b> Range: 0 .. 3	Selectable Voting Logics are: <ul style="list-style-type: none"> <li>• 1oo2 : trip is released if 1 of 2 inputs signalizes trip condition</li> <li>• 2oo2 : trip is released if 2 of 2 inputs signalize trip condition</li> <li>• 2oo3 : trip is released if 2 of 3 inputs signalize trip condition</li> <li>• 3oo3 : trip is released if 3 of 3 inputs signalize trip condition</li> </ul> Setting 0 : 1oo2 (only inputs 1 and 2 of voter 3 are monitored) 1 : 2oo2 (only inputs 1 and 2 of voter 3 are monitored) 2 : 2oo3 (all three inputs of voter 3 are monitored) 3 : 3oo3 (all three inputs of voter 3 are monitored)																													
<b>P12.03</b> <b>Truth Time until Trip</b> Range: 0 .. 7	If the trip signal is shorter than the minimum truth time, the signal is not valid (anti bouncing filter). If the signal is longer than the maximum truth time, the signal is valid and trip is released Note: Signal truth times in between min. and max. may release trip. <table border="1" data-bbox="986 1200 1412 1532" style="margin-left: auto; margin-right: auto;"> <thead> <tr> <th rowspan="2">Setting</th> <th colspan="2">Trip after</th> </tr> <tr> <th>min.</th> <th>max.</th> </tr> </thead> <tbody> <tr> <td>0</td> <td>0 msec</td> <td>4 msec</td> </tr> <tr> <td>1</td> <td>3 msec</td> <td>12 msec</td> </tr> <tr> <td>2</td> <td>9 msec</td> <td>36 msec</td> </tr> <tr> <td>3</td> <td>18 msec</td> <td>54 msec</td> </tr> <tr> <td>4</td> <td>36 msec</td> <td>108 msec</td> </tr> <tr> <td>5</td> <td>72 msec</td> <td>216 msec</td> </tr> <tr> <td>6</td> <td>144 msec</td> <td>432 msec</td> </tr> <tr> <td>7</td> <td>288 msec</td> <td>864 msec</td> </tr> </tbody> </table> Maximum response time until trip-lines go to trip status is maximum truth time + 3 milliseconds.	Setting	Trip after		min.	max.	0	0 msec	4 msec	1	3 msec	12 msec	2	9 msec	36 msec	3	18 msec	54 msec	4	36 msec	108 msec	5	72 msec	216 msec	6	144 msec	432 msec	7	288 msec	864 msec
Setting	Trip after																													
	min.	max.																												
0	0 msec	4 msec																												
1	3 msec	12 msec																												
2	9 msec	36 msec																												
3	18 msec	54 msec																												
4	36 msec	108 msec																												
5	72 msec	216 msec																												
6	144 msec	432 msec																												
7	288 msec	864 msec																												
<b>P12.04</b> <b>Trip by Voter3 latched</b> Range: 0 .. 1	Setting 0 : trip by voter 3 is not latched 1 : trip by voter 3 is latched until reset																													

Parameter Group P12.xx (continued) of Monitor E1668 Voter 3 and Logic Output LO3	
Parameter No. Meaning of Parameter Setting Range of Parameter	Description of Parameters and their Settings
<b>P12.05</b> <b>Delay of Antivalence Alarm</b> Range: 0 .. 9	<p>To avoid unnecessary Antivalence Alarms due to shifted trip release signals at the voter inputs a delay may be introduced. Antivalence alarm will then be released only if the time shift between the signals exceeds the set delay.</p> <p>Setting</p> <ul style="list-style-type: none"> <li>0 : no delay</li> <li>1 : delay = 100 milliseconds</li> <li>2 : delay = 500 milliseconds</li> <li>3 : delay = 1 second</li> <li>4 : delay = 2 seconds</li> <li>5 : delay = 3 seconds</li> <li>6 : delay = 5 seconds</li> <li>7 : delay = 15 seconds</li> <li>8 : delay = 30 seconds</li> <li>9 : delay = 60 seconds</li> </ul> <p><b>Note:</b> The input signals will be monitored for antivalence only, if the voter is active.</p>
<b>P12.06</b> <b>Setpoint SPV3</b> Range: 00001 .. 99999 [RPM]	<p>Depending on setting of P12.00, SPV3 controls the activity of voter 3 or controls directly the output LO3. SPV3 is set in terms of RPM.</p>
<b>P12.07</b> Reserved for future application	
<b>P12.08</b> Reserved for future application	

**Parameter Group P13.xx of Monitor E1668  
Voter 4 and Logic Output LO4**

<b>Parameter No. Meaning of Parameter Setting Range of Parameter</b>	<b>Description of Parameters and their Settings</b>																													
<b>P13.00</b> <b>Operation mode Voter 4</b> Range: 0 .. 5	Setting 0 : Voter inactive 1 : Voter always active (over entire speed range) 2 : Voter only active, if n > SPV4 3 : Voter only active, if n < SPV4 4 : Voter inactive, output LO4 low, if n > SPV4 5 : Voter inactive, output LO4 high, if n > SPV4																													
<b>P13.01</b> <b>Input Truth Level</b> Range: 0 .. 1	Setting 0 : high level at inputs is assigned to trip condition 1 : low level at inputs is assigned to trip condition																													
<b>P13.02</b> <b>Voting Logic</b> Range: 0 .. 3	Selectable Voting Logics are: <ul style="list-style-type: none"> <li>• 1oo2 : trip is released if 1 of 2 inputs signalizes trip condition</li> <li>• 2oo2 : trip is released if 2 of 2 inputs signalize trip condition</li> <li>• 2oo3 : trip is released if 2 of 3 inputs signalize trip condition</li> <li>• 3oo3 : trip is released if 3 of 3 inputs signalize trip condition</li> </ul> Setting 0 : 1oo2 (only inputs 1 and 2 of voter 4 are monitored) 1 : 2oo2 (only inputs 1 and 2 of voter 4 are monitored) 2 : 2oo3 (all three inputs of voter 4 are monitored) 3 : 3oo3 (all three inputs of voter 4 are monitored)																													
<b>P13.03</b> <b>Truth Time until Trip</b> Range: 0 .. 7	If the trip signal is shorter than the minimum truth time, the signal is not valid (anti bouncing filter). If the signal is longer than the maximum truth time, the signal is valid and trip is released Note: Signal truth times in between min. and max. may release trip. <table border="1" data-bbox="986 1198 1412 1534"> <thead> <tr> <th rowspan="2">Setting</th> <th colspan="2">Trip after</th> </tr> <tr> <th>min.</th> <th>max.</th> </tr> </thead> <tbody> <tr> <td>0</td> <td>0 msec</td> <td>4 msec</td> </tr> <tr> <td>1</td> <td>3 msec</td> <td>12 msec</td> </tr> <tr> <td>2</td> <td>9 msec</td> <td>36 msec</td> </tr> <tr> <td>3</td> <td>18 msec</td> <td>54 msec</td> </tr> <tr> <td>4</td> <td>36 msec</td> <td>108 msec</td> </tr> <tr> <td>5</td> <td>72 msec</td> <td>216 msec</td> </tr> <tr> <td>6</td> <td>144 msec</td> <td>432 msec</td> </tr> <tr> <td>7</td> <td>288 msec</td> <td>864 msec</td> </tr> </tbody> </table> Maximum response time until trip-lines go to trip status is maximum truth time + 3 milliseconds.	Setting	Trip after		min.	max.	0	0 msec	4 msec	1	3 msec	12 msec	2	9 msec	36 msec	3	18 msec	54 msec	4	36 msec	108 msec	5	72 msec	216 msec	6	144 msec	432 msec	7	288 msec	864 msec
Setting	Trip after																													
	min.	max.																												
0	0 msec	4 msec																												
1	3 msec	12 msec																												
2	9 msec	36 msec																												
3	18 msec	54 msec																												
4	36 msec	108 msec																												
5	72 msec	216 msec																												
6	144 msec	432 msec																												
7	288 msec	864 msec																												
<b>P13.04</b> <b>Trip by Voter 4 latched</b> Einstellbereich: 0 .. 1	Setting 0 : trip by voter 4 is not latched 1 : trip by voter 4 is latched until reset																													

Parameter Group P13.xx (continued) of Monitor E1668 Voter 4 and Logic Output LO4	
Parameter No. Meaning of Parameter Setting Range of Parameter	Description of Parameters and their Settings
<b>P13.05</b> <b>Delay of Antivalence Alarm</b> Range: 0 .. 9	<p>To avoid unnecessary Antivalence Alarms due to shifted trip release signals at the voter inputs a delay may be introduced. Antivalence alarm will then be released only if the time shift between the signals exceeds the set delay.</p> <p>Setting</p> <ul style="list-style-type: none"> <li>0 : no delay</li> <li>1 : delay = 100 milliseconds</li> <li>2 : delay = 500 milliseconds</li> <li>3 : delay = 1 second</li> <li>4 : delay = 2 seconds</li> <li>5 : delay = 3 seconds</li> <li>6 : delay = 5 seconds</li> <li>7 : delay = 15 seconds</li> <li>8 : delay = 30 seconds</li> <li>9 : delay = 60 seconds</li> </ul> <p><b>Note:</b> The input signals will be monitored for antivalence only, if the voter is active.</p>
<b>P13.06</b> <b>Setpoint SPV4</b> Range: 00001 .. 99999 [RPM]	<p>Depending on setting of P13.00, SPV4 controls the activity of voter 4 or controls directly the output LO4. SPV4 is set in terms of RPM.</p>
<b>P13.07</b> Reserved for future application	
<b>P13.08</b> Reserved for future application	

**Parameter Group P14.xx of Monitor E1668  
Voter 5 and Logic Output LO5**

Parameter No. Meaning of Parameter Setting Range of Parameter	Description of Parameters and their Settings																													
<b>P14.00</b> <b>Operation mode Voter 5</b> Range: 0 .. 5	Setting 0 : Voter inactive 1 : Voter always active (over entire speed range) 2 : Voter only active, if n > SPV5 3 : Voter only active, if n < SPV5 4 : Voter inactive, output LO5 low, if n > SPV5 5 : Voter inactive, output LO5 high, if n > SPV5																													
<b>P14.01</b> <b>Input Truth Level</b> Range: 0 .. 1	Setting 0 : high level at inputs is assigned to trip condition 1 : low level at inputs is assigned to trip condition																													
<b>P14.02</b> <b>Voting Logic</b> Range: 0 .. 3	Selectable Voting Logics are: <ul style="list-style-type: none"> <li>• 1oo2 : trip is released if 1 of 2 inputs signalizes trip condition</li> <li>• 2oo2 : trip is released if 2 of 2 inputs signalize trip condition</li> <li>• 2oo3 : trip is released if 2 of 3 inputs signalize trip condition</li> <li>• 3oo3 : trip is released if 3 of 3 inputs signalize trip condition</li> </ul> Setting 0 : 1oo2 (only inputs 1 and 2 of voter 5 are monitored) 1 : 2oo2 (only inputs 1 and 2 of voter 5 are monitored) 2 : 2oo3 (all three inputs of voter 5 are monitored) 3 : 3oo3 (all three inputs of voter 5 are monitored)																													
<b>P14.03</b> <b>Truth Time until Trip</b> Range: 0 .. 7	If the trip signal is shorter than the minimum truth time, the signal is not valid (anti bouncing filter). If the signal is longer than the maximum truth time, the signal is valid and trip is released Note: Signal truth times in between min. and max. may release trip. <table border="1" data-bbox="986 1229 1412 1563"> <thead> <tr> <th rowspan="2">Setting</th> <th colspan="2">Trip after</th> </tr> <tr> <th>min.</th> <th>max.</th> </tr> </thead> <tbody> <tr> <td>0</td> <td>0 msec</td> <td>4 msec</td> </tr> <tr> <td>1</td> <td>3 msec</td> <td>12 msec</td> </tr> <tr> <td>2</td> <td>9 msec</td> <td>36 msec</td> </tr> <tr> <td>3</td> <td>18 msec</td> <td>54 msec</td> </tr> <tr> <td>4</td> <td>36 msec</td> <td>108 msec</td> </tr> <tr> <td>5</td> <td>72 msec</td> <td>216 msec</td> </tr> <tr> <td>6</td> <td>144 msec</td> <td>432 msec</td> </tr> <tr> <td>7</td> <td>288 msec</td> <td>864 msec</td> </tr> </tbody> </table> Maximum response time until trip-lines go to trip status is maximum truth time + 3 milliseconds.	Setting	Trip after		min.	max.	0	0 msec	4 msec	1	3 msec	12 msec	2	9 msec	36 msec	3	18 msec	54 msec	4	36 msec	108 msec	5	72 msec	216 msec	6	144 msec	432 msec	7	288 msec	864 msec
Setting	Trip after																													
	min.	max.																												
0	0 msec	4 msec																												
1	3 msec	12 msec																												
2	9 msec	36 msec																												
3	18 msec	54 msec																												
4	36 msec	108 msec																												
5	72 msec	216 msec																												
6	144 msec	432 msec																												
7	288 msec	864 msec																												
<b>P14.04</b> <b>Trip by Voter 5 latched</b> Range: 0 .. 1	Setting 0 : trip by voter 5 is not latched 1 : trip by voter 5 is latched until reset																													

Parameter Group P14.xx (continued) of Monitor E1668 Voter 5 and Logic Output LO5	
Parameter No. Meaning of Parameter Setting Range of Parameter	Description of Parameters and their Settings
<b>P14.05</b> <b>Delay of Antivalence Alarm</b> Range: 0 .. 9	<p>To avoid unnecessary Antivalence Alarms due to shifted trip release signals at the voter inputs a delay may be introduced. Antivalence alarm will then be released only if the time shift between the signals exceeds the set delay.</p> <p>Setting</p> <ul style="list-style-type: none"> <li>0 : no delay</li> <li>1 : delay = 100 milliseconds</li> <li>2 : delay = 500 milliseconds</li> <li>3 : delay = 1 second</li> <li>4 : delay = 2 seconds</li> <li>5 : delay = 3 seconds</li> <li>6 : delay = 5 seconds</li> <li>7 : delay = 15 seconds</li> <li>8 : delay = 30 seconds</li> <li>9 : delay = 60 seconds</li> </ul> <p><b>Note:</b> The input signals will be monitored for antivalence only, if the voter is active.</p>
<b>P14.06</b> <b>Setpoint SPV5</b> Range: 00001 .. 99999 [RPM]	<p>Depending on setting of P14.00, SPV5 controls the activity of voter 5 or controls directly the output LO5. SPV5 is set in terms of RPM.</p>
<b>P14.07</b> Reserved for future application	
<b>P14.08</b> Reserved for future application	

**Parameter Group P15.xx of Monitor E1668  
Voter 6 and Logic Output LO6**

<b>Parameter No. Meaning of Parameter Setting Range of Parameter</b>	<b>Description of Parameters and their Settings</b>																													
<b>P15.00</b> <b>Operation mode Voter 6</b> Range: 0 .. 5	Setting 0 : Voter inactive 1 : Voter always active (over entire speed range) 2 : Voter only active, if n > SPV6 3 : Voter only active, if n < SPV6 4 : Voter inactive, output LO6 low, if n > SPV6 5 : Voter inactive, output LO6 high, if n > SPV6																													
<b>P15.01</b> <b>Input Truth Level</b> Range: 0 .. 1	Setting 0 : high level at inputs is assigned to trip condition 1 : low level at inputs is assigned to trip condition																													
<b>P15.02</b> <b>Voting Logic</b> Range: 0 .. 3	Selectable Voting Logics are: <ul style="list-style-type: none"> <li>• 1oo2 : trip is released if 1 of 2 inputs signalizes trip condition</li> <li>• 2oo2 : trip is released if 2 of 2 inputs signalize trip condition</li> <li>• 2oo3 : trip is released if 2 of 3 inputs signalize trip condition</li> <li>• 3oo3 : trip is released if 3 of 3 inputs signalize trip condition</li> </ul> Setting 0 : 1oo2 (only inputs 1 and 2 of voter 6 are monitored) 1 : 2oo2 (only inputs 1 and 2 of voter 6 are monitored) 2 : 2oo3 (all three inputs of voter 6 are monitored) 3 : 3oo3 (all three inputs of voter 6 are monitored)																													
<b>P15.03</b> <b>Truth Time until Trip</b> Range: 0 .. 7	If the trip signal is shorter than the minimum truth time, the signal is not valid (anti bouncing filter). If the signal is longer than the maximum truth time, the signal is valid and trip is released Note: Signal truth times in between min. and max. may release trip. <table border="1" data-bbox="986 1198 1412 1534"> <thead> <tr> <th rowspan="2">Setting</th> <th colspan="2">Trip after</th> </tr> <tr> <th>min.</th> <th>max.</th> </tr> </thead> <tbody> <tr> <td>0</td> <td>0 msec</td> <td>4 msec</td> </tr> <tr> <td>1</td> <td>3 msec</td> <td>12 msec</td> </tr> <tr> <td>2</td> <td>9 msec</td> <td>36 msec</td> </tr> <tr> <td>3</td> <td>18 msec</td> <td>54 msec</td> </tr> <tr> <td>4</td> <td>36 msec</td> <td>108 msec</td> </tr> <tr> <td>5</td> <td>72 msec</td> <td>216 msec</td> </tr> <tr> <td>6</td> <td>144 msec</td> <td>432 msec</td> </tr> <tr> <td>7</td> <td>288 msec</td> <td>864 msec</td> </tr> </tbody> </table> Maximum response time until trip-lines go to trip status is maximum truth time + 3 milliseconds.	Setting	Trip after		min.	max.	0	0 msec	4 msec	1	3 msec	12 msec	2	9 msec	36 msec	3	18 msec	54 msec	4	36 msec	108 msec	5	72 msec	216 msec	6	144 msec	432 msec	7	288 msec	864 msec
Setting	Trip after																													
	min.	max.																												
0	0 msec	4 msec																												
1	3 msec	12 msec																												
2	9 msec	36 msec																												
3	18 msec	54 msec																												
4	36 msec	108 msec																												
5	72 msec	216 msec																												
6	144 msec	432 msec																												
7	288 msec	864 msec																												
<b>P15.04</b> <b>Trip by Voter 6 latched</b> Range: 0 .. 1	Setting 0 : trip by voter 6 is not latched 1 : trip by voter 6 is latched until reset																													

Parameter Group P15.xx (continued) of Monitor E1668 Voter 6 and Logic Output LO6	
Parameter No. Meaning of Parameter Setting Range of Parameter	Description of Parameters and their Settings
<b>P15.05</b> <b>Delay of Antivalence Alarm</b> Range: 0 .. 9	<p>To avoid unnecessary Antivalence Alarms due to shifted trip release signals at the voter inputs a delay may be introduced. Antivalence alarm will then be released only if the time shift between the signals exceeds the set delay.</p> <p>Setting</p> <ul style="list-style-type: none"> <li>0 : no delay</li> <li>1 : delay = 100 milliseconds</li> <li>2 : delay = 500 milliseconds</li> <li>3 : delay = 1 second</li> <li>4 : delay = 2 seconds</li> <li>5 : delay = 3 seconds</li> <li>6 : delay = 5 seconds</li> <li>7 : delay = 15 seconds</li> <li>8 : delay = 30 seconds</li> <li>9 : delay = 60 seconds</li> </ul> <p><b>Note:</b> The input signals will be monitored for antivalence only, if the voter is active.</p>
<b>P15.06</b> <b>Setpoint SPV6</b> Range: 00001 .. 99999 [RPM]	<p>Depending on setting of P15.00, SPV6 controls the activity of voter 6 or controls directly the output LO6. SPV6 is set in terms of RPM.</p>
<b>P15.07</b> Reserved for future application	
<b>P15.08</b> Reserved for future application	

<b>Parameter Group P16.xx of Monitor E1668</b> <b>Reserved for future application</b>	
<b>Parameter No.</b> <b>Meaning of Parameter</b> Setting Range of Parameter	<b>Description of Parameters and their Settings</b>
<b>P16.00</b> Reserved for future application	
<b>P16.01</b> Reserved for future application	
<b>P16.02</b> Reserved for future application	
<b>P16.03</b> Reserved for future application	
<b>P16.04</b> Reserved for future application	
<b>P16.05</b> Reserved for future application	
<b>P16.06</b> Reserved for future application	
<b>P16.07</b> Reserved for future application	
<b>P16.08</b> Reserved for future application	

<b>Parameter Group P17.xx of Monitor E1668</b> <b>PROFIBUS</b>	
<b>Parameter No.</b> <b>Meaning of Parameter</b> Setting Range of Parameter	<b>Description of Parameters and their Settings</b>
<b>P17.00</b> <b>Device No. for PROFIBUS</b> Range: 001 .. 125	All members of the PROFIBUS-Communication must have different device nos.
<b>P17.01</b> <b>Address Offset for redundant PROFIBUS Interface</b> Range: 0 .. 9	For test purposes (operation of both PROFIBUS Interfaces at the same Bus) an address offset may be introduced for the redundant (right one on front panel) PROFIBUS Interface. Example: With P17.00 = 34 und P17.01 = 4 the right hand side PROFIBUS Interface has adress 38.



## 10.2 Description of Parameters and their Settings of Test-Generator E1698

Parameter Group P00.xx of Test-Generator E1698 Code Figure, Parameter Lock	
Parameter No. Meaning of Parameter Setting Range of Parameter	Description of Parameters and their Settings
<b>P00.00</b> <b>Code Figure</b> Range: 0000 .. 9999	If the parameters are locked (see P00.02), the code figure must be entered prior to any change of other parameters. If the code figure is not correct, -E 1- is displayed. Without code figure and P00.02 : 0 the values of all parameters may be inspected, but not changed.
<b>P00.01</b> <b>New Code Figure</b> Range: 0000 .. 9999	A new code figure may be set in P00.01. Then it replaces the previous one.
<b>P00.02</b> <b>Parameter Lock</b> Range: 0 .. 1	Setting 0 : Parameters are locked, change only possible with code figure 1 : Parameters unlocked, change of parameter values possible

Parameter Group P01.xx of Test-Generator E1698 Output Scaling	
Parameter No. Meaning of Parameter Setting Range of Parameter	Description of Parameters and their Settings
<b>P01.00</b> Reserved for future applications	
<b>P01.01</b> <b>Nominal Output Frequency at nominal Test-Speed</b> Range: 00001 .. 99999 [Hz]	See description of Scaling
<b>P01.02</b> Reserved for future applications	
<b>P01.03</b> <b>Nominal Test-Speed</b> Range: 00001 .. 99999 [RPM]	See description of Scaling

Parameter Group P02.xx of Test-Generator E1698 Monitor Test	
Parameter No. Meaning of Parameter Setting Range of Parameter	Description of Parameters and their Settings
<b>P02.00</b> Reserved for future application	
<b>P02.01</b> Reserved for future application	
<b>P02.02</b> <b>Time Interval in between Monitor Test Sequences</b> Range: 0001 .. 9999 [min]	<p>The time interval in between the Monitor Test sequences can be set from 0001 to 9999 minutes but shall not exceed 1440 minutes during normal operation of the machine. Recommended settings: any time in between 60 and 1440 minutes.</p> <p><b>Important notes:</b></p> <ul style="list-style-type: none"> <li>• <b>Safety values according chapter 1.7 are valid only for a maximum interval of 1440 minutes</b></li> <li>• <b>Setting of values &gt; 7000 minutes may release an -E4- alarm by the E1668 monitors.</b></li> </ul>
<b>P02.03</b> <b>Test of SP1</b> or <b>Test of SP1A and SP1B</b> Range: 0 .. 3	<p>De-Energize/Energize depends on the setting of P03.02 of monitors E1668.</p> <p>Setting</p> <ul style="list-style-type: none"> <li>0 : if test of SP1 only is required</li> <li>1 : not permissible</li> <li>2 : not permissible</li> <li>3 : if test of SP1A and SP1B is required</li> </ul> <p>Explanation:</p> <p>If P02.03 = 0 or 2, then Test-Speed 1 and 2: In the first step of the monitor auto test sequence, the monitor is tested with test-speed 1. Value for test-speed 1 must be &gt; SP1 of monitor. In the second step of the monitor auto test sequence, the monitor is tested with test-speed 2. Value for test-speed 2 must be &lt; SP1 of monitor.</p> <p>Example:</p> <p>SP1 of monitor is set to 3300 RPM. Recommended value for Test-speed 1 : 3305 RPM Recommended value for Test-speed 2 : 3295 RPM</p> <p>If P02.03 = 3, then P02.04 must be set to SP1A (P03.00 of E1667) and P02.05 must be set to SP1B (P03.03 of E1667). Test will then be performed with Test-Speed SP1A +/- 5RPM and with Test-Speed SP1B +/- 5RPM.</p> <p><b>Note:</b> <b>Automatic test of SP1B (P02.03 = 3) is not possible if the normal operational speed is higher than SP1B (would result in a system trip during the automatic test).</b></p>

<b>Parameter Group P02.xx (continued) of Test-Generator E1698 Monitor Test</b>	
<b>Parameter No. Meaning of Parameter Setting Range of Parameter</b>	<b>Description of Parameters and their Settings</b>
<b>P02.04</b> <b>Test-Speed 1 resp. SP1A</b> Range: 00001 .. 99999 [RPM]	See explanation of step P03.02
<b>P02.05</b> <b>Test-Speed 2 resp. SP1B</b> Range: 00001 .. 99999 [RPM]	See explanation of step P03.02

Parameter Group P03.xx of Test-Generator E1698 Trip-Line Test	
Parameter No. Meaning of Parameter Setting Range of Parameter	Description of Parameters and their Settings
<b>P03.00</b> <b>Time Interval in between Trip-Line Test Sequences</b> Range: 00001 .. 65000 [min]	The time interval in between automatic (see P03.01) Trip-Line Test sequences can be set from 00001 to 65000 minutes. Recommended settings: not less than 60 minutes.  <b>Note:</b> <b>The Trip-Line-Test is not relevant for the safety values according chapter 1.7.</b>
<b>P03.01</b> <b>Trip-Line Test Mode</b> Range: 0 .. 6	Setting 0 : Trip-Line Test off, feedback signal from 2oo3 solenoid valve block are not evaluated) 1 : Trip-Line Test sequence in automatic mode (cyclic, interval as set in P03.00); feedback signals from 2oo3 solenoid valve block will be evaluated. If the feedback does not signalize trip status, the output will hold the corresponding Trip-Line on trip status and the test is aborted. 2 : Trip-Line Test controlled by external signals, simultaneous test of 2 or 3 lines is inhibited, feedback signals from 2oo3 solenoid valve block are not evaluated 3 : one single Trip-Line Test Sequence, externally triggered by signal Start Auto-Test-Sequence; feedback signals from 2oo3 solenoid valve block will be evaluated, 4 : Trip-Line Test controlled by external signals, simultaneous test of 2 or 3 lines is possible, feedback signal from Valve Control Circuits are not evaluated. 5 : Trip-Line Test sequence in automatic mode (cyclic, interval as set in P03.00); feedback signals from 2oo3 solenoid valve block will be evaluated. If the feedback does not signalize trip status, the output will return to No Trip status and the test is aborted. 6 : Reserved for future application
<b>P03.02</b> Reserved for future application	
<b>P03.03</b> <b>Feedback Level from 2oo3 solenoid valve block at trip state</b> Range: 0 .. 1	Setting 0 : low level feedback expected at trip state 1 : high level feedback expected at trip state
<b>P03.04</b> Fix value 0, do not change	

Parameter Group (continued) P03.xx of Test-Generator E1698 Trip-Line Test	
Parameter No. Meaning of Parameter Setting Range of Parameter	Description of Parameters and their Settings
<b>P03.05</b> <b>Duration of Trip-Line Test</b> Range: 00 .. 99 [s]	If automatic sequence is activated (P03.01 = 1 or = 3), each Trip-Line is set (subsequently) to trip condition for the duration set in P03.05. Duration is set in terms of seconds. <b>Note:</b> Setting 00 sets the Trip-Line to trip condition for 0.5 seconds.
<b>P03.06</b> Reserved for future application	
<b>P03.07</b> <b>Waiting Time after Reset of Alarms</b> Range: 00 .. 99 [s]	After a reset of an alarm, the Test-Generator waits for this time before it starts to check the external feedback signals. Waiting time is set in terms of seconds. <b>Note:</b> Setting 00 equals 01.
<b>P03.08</b> <b>Waiting Time after test of a Trip-Line</b> Range: 00 .. 99 [s]	The Test-Generator waits after the test of a Trip-Line for this time before it permanently checks again the status of the feedback signals from the Trip-Lines for No-Trip-state. Waiting time is set in terms of seconds. <b>Note:</b> Setting 00 equals 01.
<b>P03.09</b> Reserved for future application	

Parameter Group P04.xx of Testgenerator E1698 Only used for E16A358 systems	
Parameter No. Meaning of Parameter Setting Range of Parameter	Description of Parameters and their Settings
<b>P04.00</b> Fix value = 0, do not change	

Parameter Group P05.xx of Testgenerator E1698 PROFIBUS	
Parameter No. Meaning of Parameter Setting Range of Parameter	Description of Parameters and their Settings
<b>P05.00</b> <b>Device No. for PROFIBUS</b> Range: 001 .. 125	All members of the PROFIBUS-Communication must have different device nos.
<b>P05.01</b> <b>Address Offset for redundant PROFIBUS Interface</b> Range: 0 .. 9	For test purposes (operation of both PROFIBUS Interfaces at the same Bus) an address offset may be introduced for the redundant (right one on front panel) PROFIBUS Interface. <b>Example:</b> With P05.00 = 33 und P05.01 = 4 the right hand side PROFIBUS Interface has adress 37.

## 11 Event codes and Troubleshooting

### 11.1 Event codes on display of Monitor E1668

The Event codes are shown in format E.0.x.x.x .

Depending on setting of P02.11 only the first occurred fault or all faults are displayed (combination of faults is possible).

Display	Explanation of Event code
CE-1	Trip Outputs of Monitor are forced to Trip condition by Testgenerator due to incorrect response at test. Countermeasure: If fault returns after Reset, exchange Monitor. If fault still returns, exchange Testgenerator
E.0.0.0.0	Overspeed trip (if P03.02 = 0)
E.0.x.x.1	Sensor failure (current or voltage), refer to P02.05
E.0.x.x.2	Deviation of primary sensor versus neighbor sensors, refer to P02.07
E.0.x.x.3	E.x.x.x.1 + E.x.x.x.2
E.0.x.x.4	Speed < SP2
E.0.x.x.5	E.x.x.x.1 + E.x.x.x.4
E.0.x.x.6	E.x.x.x.2 + E.x.x.x.4
E.0.x.x.7	E.x.x.x.1 + E.x.x.x.2 + E.x.x.x.4
E.0.0.1.0	Generator tests with zero speed
E.0.0.2.0	Trip by Voter or by Watchdog
<b>E.0.0.4.0</b>	<b>Internal fault, Monitor is in trip status: Replacement of Monitor asap is strongly recommended. Do not try to reset this fault, otherwise possible trip release if fault reappears during Self-Test of another Monitor.</b>
E.0.1.0.0	Failure detection during internal self test
E.0.2.x.x	Overspeed trip (if P03.02 = 1)
E.0.3.x.x	E.x.1.x.x + E.x.2.x.x
E.0.4.0.0 without Trip	Alarm caused by antivalence of Voter Signals or signals for Trip-Line-Monitoring (for troubleshooting refer to next page)
E.0.4.0.0 with Trip	Trip-Line Monitoring has caused trip
E.0.4.2.0	Trip by voter (with non-coincidence at inputs of voter)
E.0.6.x.x	E.x.2.x.x + E.x.4.x.x
E.0.8.0.0	Trip-Line Monitoring has caused trip plus antivalence of signals for Trip-Line-Monitoring (for troubleshooting refer to next page)
E.0.A.0.0	Trip due to overspeed (and P07.00 = 1 or 3)
E.0.c.0.0	Trip-Line Monit by antivalence of signals for Trip-Line-Monitoring (for troubleshooting refer to next page)
E.3.0.1.0	Starter active at speed > 50% of value of SP1A (only if P02.06 = 1 or 2)
E.3.0.2.0	External Analog output error (short circuit / 'no load' detected via feedback from monitor terminals)
E.3.0.2.1	Internal Analog output error (fault on monitor board)

E.3.1.0.0	Value of SP1B larger than SP1A, if P03.04 = 1 : not permissible
E.4.0.0.1	Power supply of Trip-Line I is off
E.4.0.0.2	Power supply of Trip-Line II is off
E.4.0.0.3	Power supply of Trip-Lines I and II is off
E.4.0.0.4	Power supply of Trip-Line III is off
E.4.0.0.5	Power supply of Trip-Lines I and III is off
E.4.0.0.6	Power supply of Trip-Lines II and III is off
E.6.0.0.1	Parameter value changed via RS232-Interface
-E1-	Wrong code figure in step P00.00
-E4-	No test by E1698 for more than 7 days (releases also Monitor Warning Alarm)

## 11.2 Troubleshooting if display of Monitor reads E.0.4.0.0

Display E.0.4.x.x signalizes a fault (not all signals are identical) from the input signals for the voters or for Trip-Line-Monitoring (resp. feedbacks from 2oo3-solenoid).  
The actual status of the signal inputs is shown in Special Display Mode 2.

Switching between Standard and Special Display Mode 2 by pressing keys **[P]** and **[Δ]** simultaneously.

In Special Display Mode 2 LED1 and LED4 are blinking.

Steps of Special Display Mode 2:

- 0.\_x.x.x
- 1.\_x.x.x
- 2.\_x.x.x
- 3.\_x.x.x
- 4.\_x.x.x

Steps of Special Display Mode 2 are selected with key **[Δ]** (next step) resp. key **[▽]** (previous step).

For troubleshooting only steps 3.\_x.x.x and 4.\_x.x.x are relevant.

The status of signal inputs for Trip-Line-Monitoring are shown in step 3.

Display of:

- 3.\_x.x.1 : Feedback signal from Trip-Line I is true
- 3.\_x.x.2 : Feedback signal from Trip-Line II is true
- 3.\_x.x.4 : Feedback signal from Trip-Line III is true

resp. all combinations hereof, for example:

- 3.\_x.x.7 : all Feedback signal from Trip-Lines are true

The voter signal inputs are shown in step 4.\_x.x.x

Display of:

- 4.n.0.0.1 : Voter n, input 1 active n = 1 - 6 (7 reserved)
- 4.n.0.0.2 : Voter n, input 2 active
- 4.n.0.0.4 : Voter n, input 3 active

resp. all combinations hereof, for example:

- 4.3.0.0.5 : Voter 3, inputs 1 und 3 active, input 2 not active

While key **[◀]** is pressed, the input status latched at error will be shown, else the current input status.

Switch the input status of voter 1 to 6 with key **[E]**.

### 11.3 Event codes on display of Testgenerator E1698

Display	Explanation of Event code
C0-E1	Trip status notification from Monitor A
C0-E2	Trip status notification from Monitor B
C0-E3	Trip status notification from Monitor A + B
C0-E4	Trip status notification from Monitor C
C0-E5	Trip status notification from Monitor A + C
C0-E6	Trip status notification from Monitor B + C
C0-E7	Trip status notification from Monitor A + B + C
C1-E1	Fault during Test of Monitor A at step 1
C1-E2	Fault during Test of Monitor A at step 2
C1-E3	Fault during Test of Monitor A at step 3
C2-E1	Fault during Test of Monitor B at step 1
C2-E2	Fault during Test of Monitor B at step 2
C2-E3	Fault during Test of Monitor B at step 3
C3-E1	Fault during Test of Monitor C at step 1
C3-E2	Fault during Test of Monitor C at step 2
C3-E3	Fault during Test of Monitor C at step 3
C9-E1	Fault of Monitor A subsequent to a test step
C9-E2	Fault of Monitor B subsequent to a test step
C9-E4	Fault of Monitor C subsequent to a test step
C9-E7	All Monitors on Trip at start of test
ECh0.1	Alarm notification from Monitor A
ECh0.2	Alarm notification from Monitor B
ECh0.3	Alarm notification from Monitor A + B
ECh0.4	Alarm notification from Monitor C
ECh0.5	Alarm notification from Monitor A + C
ECh0.6	Alarm notification from Monitor B + C
ECh0.7	Alarm notification from Monitor A + B + C

**Event codes on display of E1698 (continued)**

<b>Display</b>	<b>Explanation of Event code</b>	<b>(y = not relevant with this code)</b>
E.0.y.y.1	Trip-Line I in Trip-Status	
E.0.y.y.2	Trip-Line II in Trip-Status	
E.0.y.y.4	Trip-Line III in Trip-Status	
E.0.y.y.7	Trip-Lines I, II, III in Trip-Status	
E.1.y.y.0	Incorrect feedback from Trip-Line I at test of Trip-Line I	
E.1.y.y.2	Incorrect feedback from Trip-Line II at test of Trip-Line I	
E.1.y.y.4	Incorrect feedback from Trip-Line III at test of Trip-Line I	
E.2.y.y.0	Incorrect feedback from Trip-Line II at test of Trip-Line II	
E.2.y.y.4	Incorrect feedback from Trip-Line III at test of Trip-Line II	
E.3.y.y.0	Incorrect feedback from Trip-Line III at test of Trip-Line III	
FC-5.1	Test outputs are asynchronous: if code reappears subsequent to reset, one of the test outputs has a hardware fault and E1698 must be replaced	
FC-5.2	Input Test Lock is active	
FC-5.6	Input Test Lock is active for more than 10 minutes	

## 12 Revision Notes

Date	Rev.	Modification
24.03.2013	00	First Edition
08.04.2014	00	Editorial: Description P05.03 in chapter 9.2 added with setting 2 and 3. Manual changed to Bookmark Format.
03.06.2014	00	Editorial: Double Parameter No. P06.01 (Monitor E1668) changed to P06.02. Double Parameter No. P04.00 (Testgenerator E1698) changed to P05.00.
09.02.2016	00	Editorial: Chapter 1.6: SIL3-Certificate updated Chapter 3.8: 2006/95/EU replaced by 2014/35/EC, 2004/108/EU replaced by 2014/30/EC
12.12.2019	01	Technical: Dimensions of E16A356 revised, chapter 3.11 and 3.12
25.01.2020	01	Editorial: Chapter 1.6: SIL3-Certificate updated
16.04.2020	02	Editorial: E.0.0.2.0 also displayed if Trip by Watchdog released
26.09.2022	03	Editorial: Description of FC-5.4 for E1698 added
20.06.2024	04	Editorial: Parameter P02.02 of E1698 with notes amended Parameter P03.00 of E1698 with note amended
26.12.2025	05	Editorial: Event codes added Chapter 1.6: SIL3-Certificate updated Chapter 8.6 added